

WIRELESS CONNECTIVITY & SENSORS

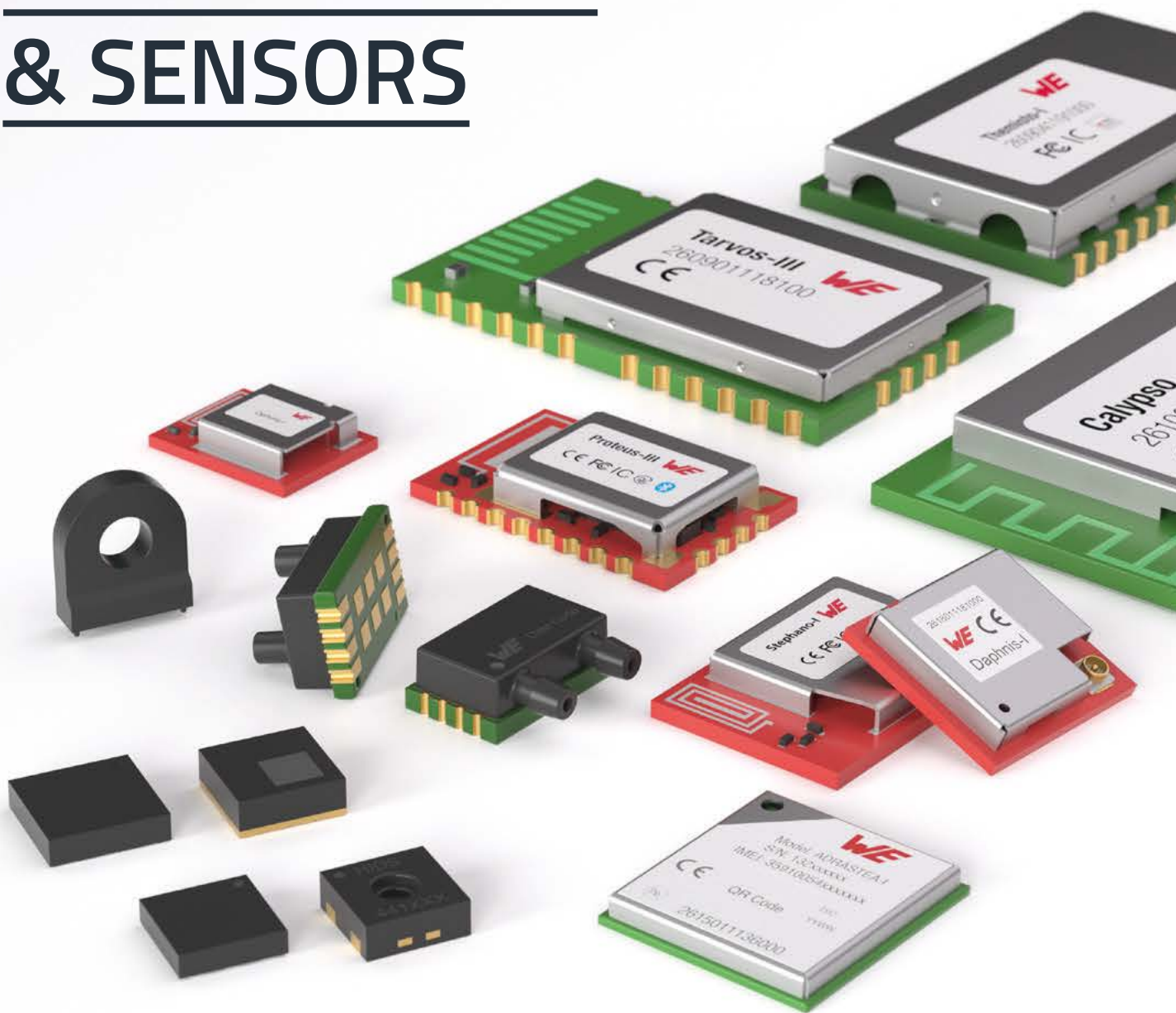





WÜRTH ELEKTRONIK MORE THAN YOU EXPECT

THE WÜRTH ELEKTRONIK eiSos GROUP



GLOBALLY AVAILABLE. LOCALLY PRESENT.

-  **13** Warehouses
-  **15** Quality & Design Centers
-  **16** Production plants
-  **50** Countries



THE WIRELESS CONNECTIVITY & SENSORS STORY

WHERE WE COME FROM

2016 was a milestone for Würth Elektronik. AMBER wireless GmbH was acquired and integrated into the Würth Elektronik eiSos Group in 2018. In parallel, Würth Elektronik set up a team around sensor technologies.

Today, with almost 25 years of experience in the development of radio products and with key people in the field of sensor technologies, Würth Elektronik established a core pillar to its future business: the division "Wireless Connectivity & Sensors".

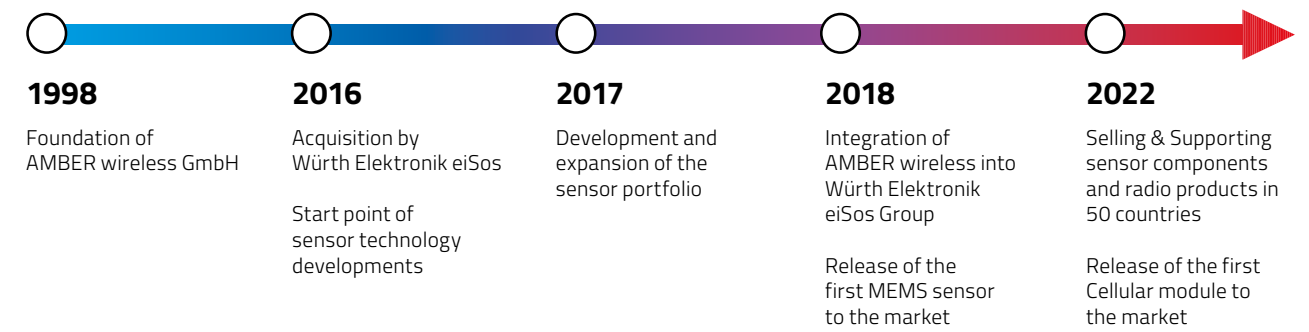

WHO WE ARE

Wireless Connectivity & Sensors - these are not just wireless modules and sensors. Behind them is a team identifying themselves passionately with the products. But it's not all about the products – it's about people, these values make us strong. Following the old AMBER claim "One for all, all for one", we are living our dedication towards the customers.

EASY AND FAST ACCESS TO ALL INFORMATION

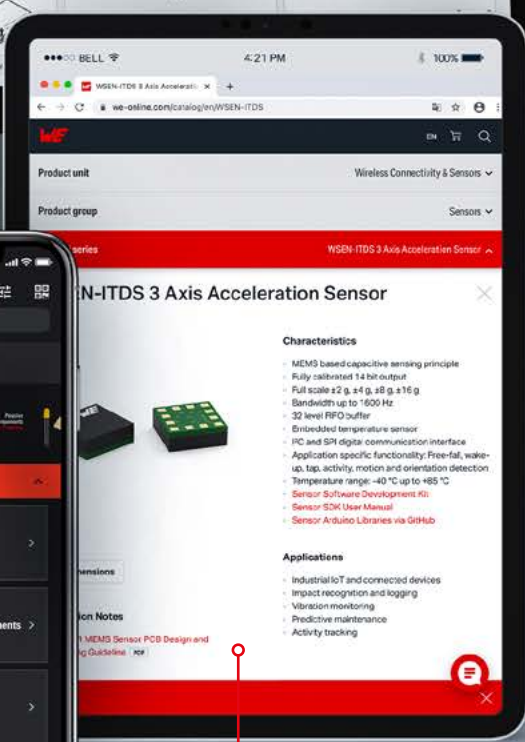
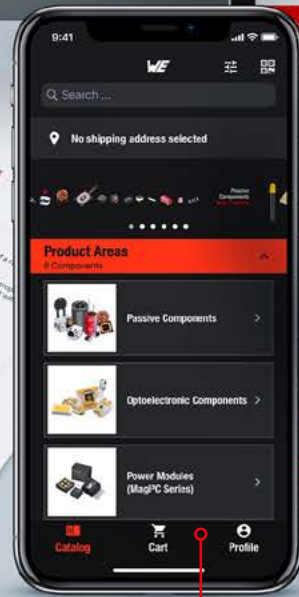
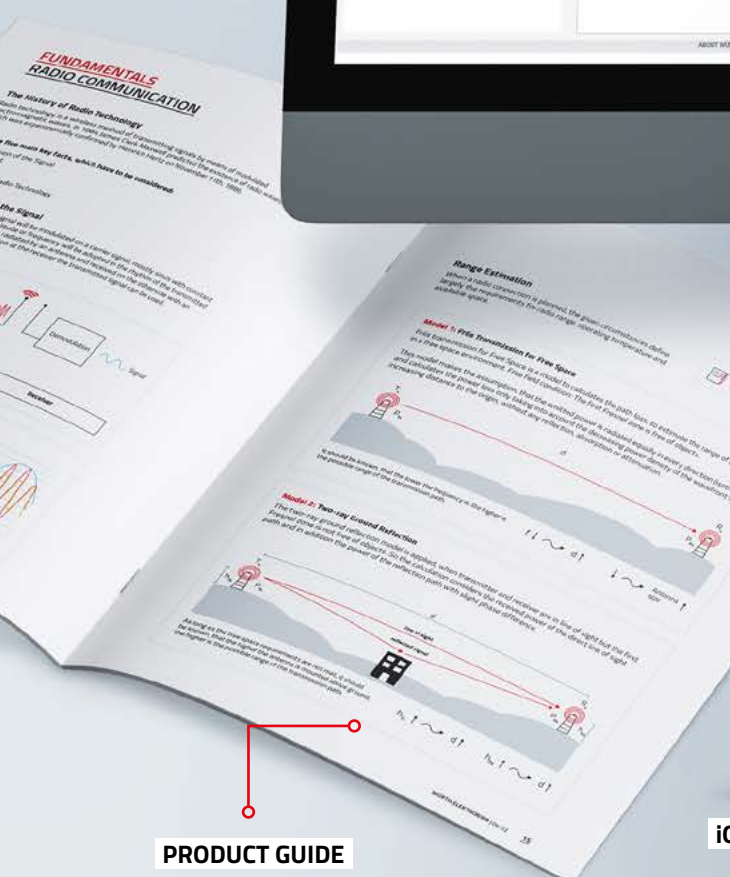
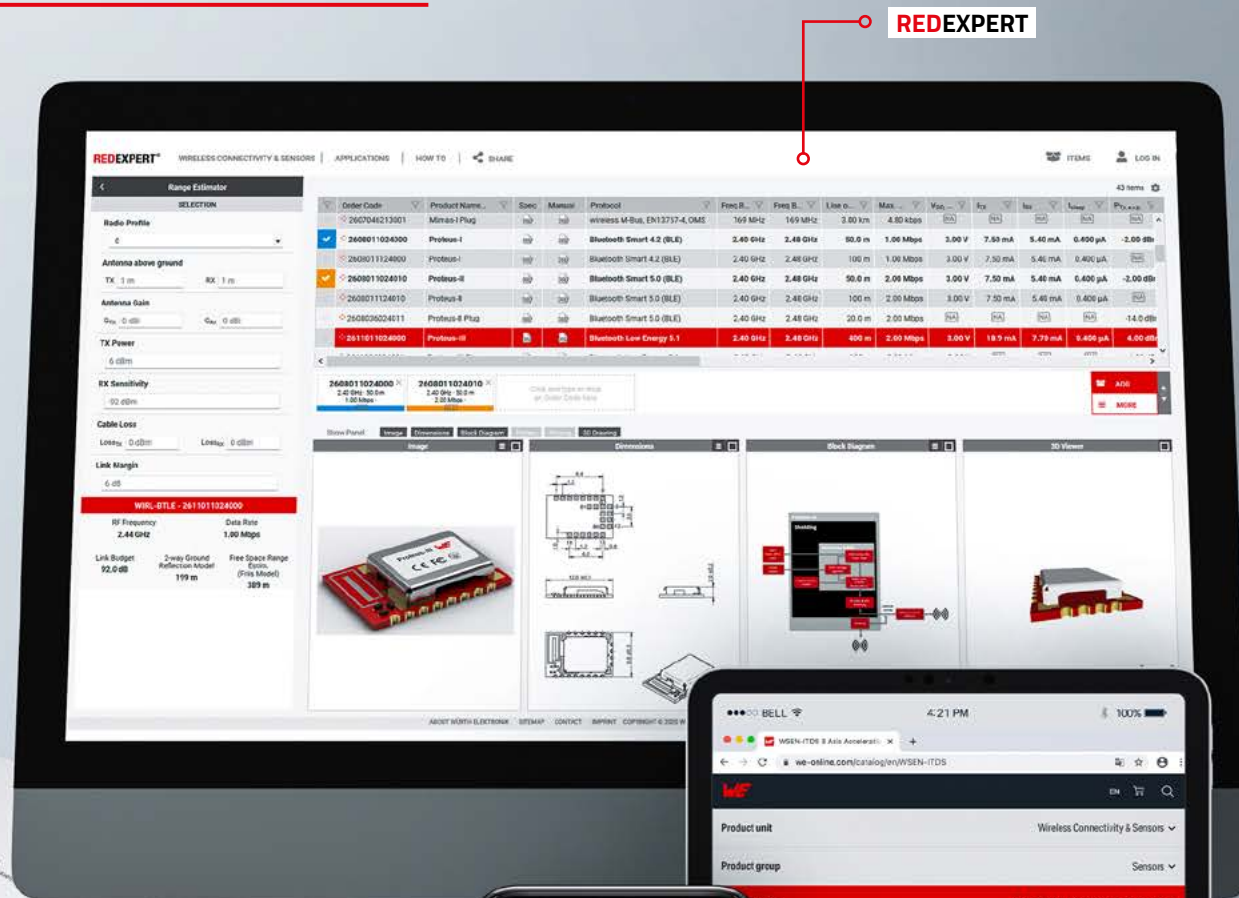

PRODUCT GUIDE

iOS APP

WEBSITE



Product Guide Online Version:
www.we-online.com/wcs-product-guide



Download the Catalogue App of Würth Elektronik to
access all product information on your mobile device:
www.we-online.com/app



Redexpert:
www.we-online.com/redexpert































CONTENT

GENERAL INTRODUCTION		
	Added Values	8
	Software Tools	12
	Evaluation Tools	16
SENSORS		
	Fundamentals	19
	Motion Sensors	25
	Environmental Sensors	31
	Pressure Sensors	37
	Current Sensors	45
	Added Values	52
WIRELESS CONNECTIVITY		
	How to get started with wireless - Fundamentals, Radio Protocols, HW-Integration, Antenna Matching, Firmware, Certification	55
	Connect Machine Globally	Cellular 91
	Connect Machine to Mobile Device	Bluetooth® 103
	Connect Machine to Internet	WiFi 119
	Connect Device to Gateway	Long-Range-WAN 131
	Connect Machine to Machine	Proprietary 139
	Connect M2M & Mobile Device	Combined 155
	Connect all together	Mesh 163
	Connect Smart Meter	Wireless M-Bus 173
	Open Module/No Firmware	Build Your Own Firmware 181
IOT		
	Fundamentals	191
	Cyber Security	195
	FeatherWings	199
	Calypto IoT Design Kit	206
	SensorBLE FeatherWing Kit	207
CREATING IDEAS		
	Industry	210
	Mobility	226
	Automation & Smart Home	234
	Consumer	248
	Energy	260
	Medical	270

Information in this publication is subject to change. The process of continually improving our product range leads to changes in content. For new designs please refer to the latest data sheets on www.we-online.com or contact our technical field staff.

ONE CLICK SELECTION

WIRELESS CONNECTIVITY		
CELLULAR	BLUETOOTH	COMBINED
 <p>Adrastea-I LTE-NB.IoT / Cat.M1 incl. GNSS incl. ARM Cortex M4 14 x 13 x 2 mm</p>	 <p>Proteus-I / -II Bluetooth® LE 4.2 Bluetooth® LE 5.0 Nordic nRF52832 3 dBm output power 11 x 8 x 2 mm</p>	 <p>Setebos-I Bluetooth® LE 5.1 & WE-ProWare 2.4 GHz Nordic nRF52840 8 dBm output power 12 x 8 x 2 mm</p>
	 <p>Proteus-III Bluetooth® LE 5.1 Nordic nRF52840 6 dBm output power 12 x 8 x 2 mm</p>	 <p>Stephano-I Bluetooth® LE 5.0 IEEE 802.11 b/g/n ESP32-C3 13 dBm output power 13 x 9.5 x 2 mm</p>
WIFI		
 <p>Calypso IEEE 802.11 b/g/n 2.4 GHz 18 dBm output power 19 x 27.5 x 4 mm</p>	 <p>Proteus-e Bluetooth® LE 5.1 Nordic nRF52805 4 dBm output power 9 x 7 x 2 mm</p>	
		PROPRIETARY
		 <p>Thadeus 433 MHz RF Pad 15 dBm output power 27 x 17 x 3.8 mm</p>
BUILD YOUR OWN FIRMWARE	LONG-RANGE-WAN	
 <p>Ophelia-I Nordic nRF52805 4 dBm output power 9 x 7 x 2 mm</p>	 <p>Daphnis-I 868 MHz Supporting Classes A, B and C 13 dBm, output power 15 x 16 x 3 mm</p>	 <p>Tarvos-III 868 MHz RF Pad / PCB Antenna 14 dBm output power 27 x 17 x 3.8 mm</p>
 <p>Ophelia-III Nordic nRF52840 6 dBm output power 12 x 8 x 2 mm</p>		 <p>Thebe-II 868 MHz RF Pad 27 dBm output power 27 x 17 x 3.8 mm</p>
	WM-BUS	
 <p>Orthosie-I ESP32-C3 13 dBm output power 13 x 9.5 x 2 mm</p>	 <p>Mimas-I 169 MHz OMS Operating mode: N (a-f) 14 dBm output power 27 x 17 x 3.8 mm</p>	 <p>Telesto-III 915 MHz RF Pad / PCB Antenna 14 dBm output power 27 x 17 x 3.8 mm</p>
	 <p>Metis-II 868 MHz OMS Operating modes S, T, C 14 dBm output power 27 x 17 x 3.8 mm</p>	 <p>Themisto-I 915 MHz RF Pad 25 dBm output power 27 x 17 x 3.8 mm</p>
WIREFAS		
 <p>Thetis-I Wirepas routing mesh protocol, 2.4 GHz Nordic nRF52840 +6 dBm output power 8 x 12 x 2 mm</p>	 <p>Metis-Analyzer 868 MHz OMS parser Operating modes S, T, C Deep packet analysis Decryption (AES128)</p>	 <p>Triton 2.4 GHz RF Pad / chip antenna 10 dBm output power 27.5 x 16 x 3.2 mm</p>
	 <p>Metis-Simulator 868 MHz OMS Operating modes S, T, C Simulates Meter Data</p>	 <p>Thyone-I 2.4 GHz Nordic nRF52840 Smart antenna selection 8 dBm output power 12 x 8 x 2 mm</p>

SENSORS		
HUMIDITY	ABSOLUTE PRESSURE	DIFFERENTIAL PRESSURE
 <p>WSEN-HIDS 16 bit humidity and temperature output I²C and SPI interface 1.5 x 1.5 x 0.5 mm</p>	 <p>WSEN-PADS 26 to 126 kPa 260 to 1260 mbar 24 bit output resolution 2 x 2 x 0.8 mm</p>	 <p>WSEN-PDUS ±0.1 kPa / ±1 mbar 15 bit digital output Analog & I²C interface 5 V supply, vertical nozzles 13.3 x 8 x 7.55 mm</p>
		 <p>WSEN-PDUS ±1 kPa / ±10 mbar 15 bit digital output Analog & I²C interface 5 V supply, vertical nozzles 13.3 x 8 x 7.55 mm</p>
TEMPERATURE	MOTION	
 <p>WSEN-TIDS Digital temp. sensor Up to ±0.25 °C typ. 16 bit output resolution 2 x 2 x 0.55 mm</p>	 <p>WSEN-ITDS 3 axis acceleration 14 bit output resolution ±2g, ±4g, ±8g, ±16g 2 x 2 x 0.7 mm</p>	 <p>WSEN-PDUS ±1 kPa / ±10 mbar 15 bit digital output Analog & I²C interface 3.3 V supply, horizontal nozzles 13.3 x 8 x 7.55 mm</p>
	 <p>WSEN-ISDS 6 axis acceleration + gyroscope 16 bit output resolution ±2g, ±4g, ±8g, ±16g ±125 dps, ..., ±2000 dps</p>	 <p>WSEN-PDUS ±10 kPa / ±100 mbar 15 bit digital output Analog & I²C interface 5 V supply, vertical nozzles 13.3 x 8 x 7.55 mm</p>
RDC-M-MODULE		
 <p>WE-RCDS Through hole For IEC 62955: 2018 39.8 x 44.9 x 13.2 mm</p>		 <p>WSEN-PDUS -100 to 1000 kPa / -1 to 10 bar 15 bit digital output Analog & I²C interface 5 V supply, vertical nozzles 13.3 x 8 x 7.55 mm</p>
 <p>WE-RCDS PCB mounting with primary conductors. For IEC 62955: 2018 49 x 34.36 x 16.3 mm</p>		 <p>WSEN-PDUS 0 to 100 kPa / 0 to 1 bar 15 bit digital output Analog & I²C interface 5 V supply, vertical nozzles 13.3 x 8 x 7.55 mm</p>
		 <p>WSEN-PDUS -100 to 1000 kPa / -1 to 10 bar 15 bit digital output Analog & I²C interface 3.3V supply, vertical nozzles 13.3 x 8 x 7.55 mm</p>
		 <p>WSEN-PDUS 0 to 1500 kPa / 0 to 15 bar 15 bit digital output Analog & I²C interface 5 V supply, vertical nozzles 13.3 x 8 x 7.55 mm</p>



Product Guide Download:
www.we-online.com/wcs-product-guide

**YOU NEED SUPPORT?
CONTACT US!**
www.we-online.com/wcs-support

MORE THAN YOU EXPECT



SAY YES TO OUR FAST AND COST-FREE DESIGN-IN SUPPORT



WE TAILOR THE QUANTITIES TO YOUR NEEDS



ALL CATALOGUE PRODUCTS AVAILABLE EX STOCK



SEMINARS & WEBINARS



ONLINE DESIGN PLATFORM FOR COMPONENT SELECTION & SIMULATION



COMPONENT LIBRARIES – MAKING HARDWARE INTEGRATION EASY



APPLICATION NOTES



TOTAL QUALITY MANAGEMENT

MORE ADDED VALUES

Full Service Products Hardware + Firmware

page: 68



Software Toolkit: APIs and Software Development Kits (SDKs)

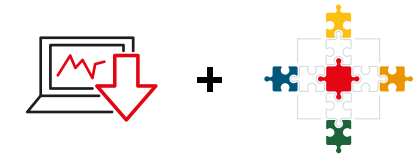

Software Individualization and Custom Sensor Characterization

page: 42

page: 80

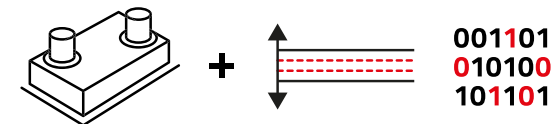

Configurable User Settings with our Firmware WE-ProWare

page: 78

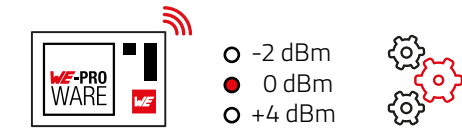

Free of Charge PC-Software and Mobile Apps

page: 12



Technical Support – Talk from Engineer to Engineer

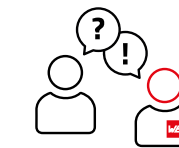

Evaluation Tools

page: 16

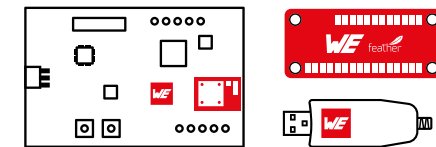

Certification and Conformity – CE, UKCA, FCC, IC, Teleg, SRRC, NCC & ETA-WPC

page: 84



Proven High Frequency PCB-Design & Proven Antenna Characteristics

page: 71

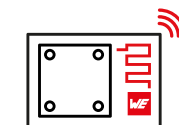

Long Term Availability



KNOWLEDGE

With the following material we would like to provide you with knowledge that will support you in your daily work.

Besides this Product Guide, we offer videos, tutorials, seminars, technical reports and other helpful materials that you can use. We are happy to assist you as a knowledge specialist.



Product Guide Online Version:
www.we-online.com/wcs-product-guide



WEBINARS

Check out our videos and webinars produced by our engineers and technology specialists. They will present you tutorials and applications, explain the use of design rules and design tips and much more. Take the opportunity to gain information within a short presentation: independent, flexible, interactive!

WIRELESS CONNECTIVITY & SENSORS

All videos on demand



SEMINARS

Missed a webinar? Not the right topic? Request your personal digital seminar! Put together an individual seminar program for you and your colleagues. It's that easy: use the request form on our homepage to select exactly the topics that interest you and arrange your preferred date with our colleagues. In digital short sessions of approx. 30 - 45 min. duration per topic, our electronics experts provide targeted insights for developers and answer your questions - live and completely free of charge.



we-online.com/Seminars

APPNOTES & MANUALS

We are happy to support you with the design in of our radio modules and sensors and provide you with detailed information in our user-friendly application notes and manuals. We go into detail about the various features, provide helpful information about processing on the board and give you additional information, for example, on the ideal use of an antenna. This allows you to quickly get an idea of the performance range of our wireless modules and sensors. Simply download the appropriate application note or manual from our online shop.



we-online.com/AppNotes

SOFTWARE TOOLS

IoT will become intelligent when hardware and software work harmoniously together!

Würth Elektronik provides a variety of software development kits (SDK) and software tools to test the wireless connection and to speed up the design processes. All tools and software development kits, can be downloaded for free in our online shop as required by their application.

GitHub

Würth Elektronik eiSos GitHub page

In order to ensure ease-of-use for the developers, all our SDK are available on the GitHub platform. Please visit the Würth Elektronik eiSos GitHub page to find the latest version of our SDKs.



github.com/WurthElektronik

Wireless Connectivity Software Development Kit (SDK)

The aim of the Wireless Connectivity SDK is to minimize the effort required on customer side to enable his host MCU to communicate with Würth Elektronik eiSos radio modules. It contains the implementation of all available commands in pure C-code. In order to integrate any Würth Elektronik eiSos wireless module, the user has to simply port the corresponding C-code to his host processor. This significantly reduces the time needed for developing the software interface to the radio module.



we-online.com/WCO-SDK

Smart Commander Tool

The WE Smart Commander is an easy-to-use PC software that enables complete control of the Würth Elektronik eiSos wireless modules through an intuitive GUI. This tool along with the evaluation boards allow quick prototyping and testing of various features of the radio modules.

- Simple setup
- Intuitive interface
- Color coded packet interpretation
- 100% log traceability

The Smart Commander itself is an executable and does not require installation. It will create folders and files on the hard drive e.g. for log file storing. However, the serial-to-USB FTDI converter chip (i.e. FT232R) on the evaluation platform or USB dongles requires special drivers to be installed for proper operation. To use USB dongles or evaluation boards of Würth Elektronik eiSos wireless connectivity modules, the Virtual COM Port (VCP) drivers have to be installed by following the "Installation Guides" of FTDI found under:



we-online.com/SmartCommander

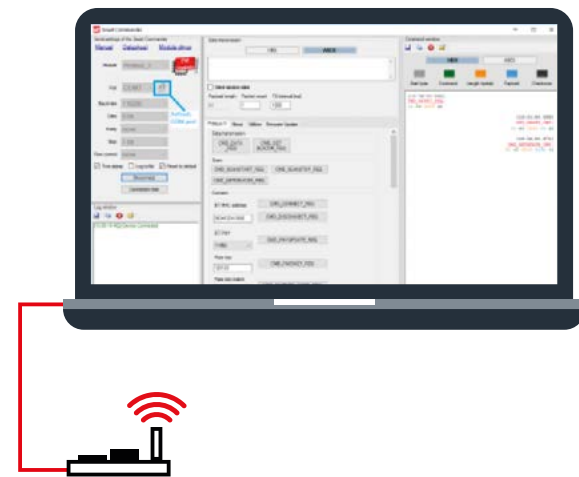

AT Commander Tool

The AT command tool is a simple PC software that enables complete control of the Calypso WiFi module via the AT Command interface. This tool offers an intuitive graphical user interface that enables the user to interact with the Calypso and understand the syntax and semantics of the AT command interface. The AT command tool works out-of-the-box with the Calypso evaluation board, allows quick prototyping and testing of various features of the Calypso WiFi module.



we-online.com/AT-Commander

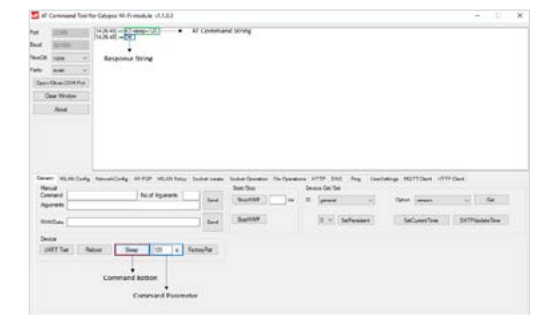

Wirepas Commander Tool

The Wirepas module Commander is an easy-to-use PC software that enables complete control of the Wirepas module via its command interface. This tool offers an intuitive graphical user interface that enables the user to interact with the wireless module and understand the communication protocol between the module and the connected host.

The Wirepas module Commander along with the Wirepas module allows quick prototyping and testing of various features of the Wirepas mesh network.



we-online.com/Wirepas-Commander

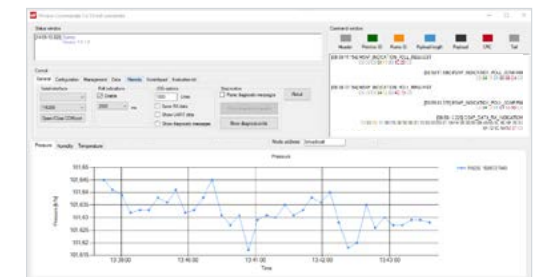

ACC-Tool

The "ACC V3" is a tool to update and configure certain Würth Elektronik eiSos modules. The supported features will include the search and upload of new firmwares as well as the modification of the available configuration parameters. It allows full user control over all supported products, as in the range of the producer's intentions, always referring to the respective manual of the connected module.

Due to current export legal restrictions, we are required to control the provision of software. To download the software, please contact our technical support or your local sales representative directly.



Contact technical support:

support@we-online.com



we-online.com/ACC

SOFTWARE TOOLS

Adrastea Commander

The Adrastea Commander is a simple PC tool to interact with the EV-Boards of the Würth Elektronik eiSos cellular module via AT command interface. This offers evaluation of Adrastea-I module capabilities and features. It is simplified for the configuration of the module using AT commands without knowledge of the protocols. Quick selection and Command List allows to save and send AT commands with a mouse click.

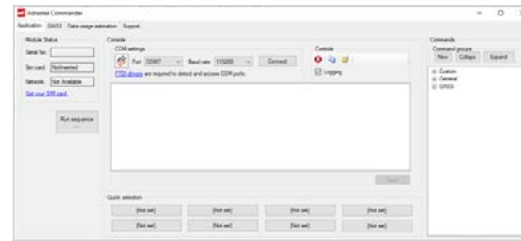

The Adrastea Commander tool makes easy evaluation of GNSS functionality of Adrastea-I module. The Adrastea Commander tool also offers data usage estimation to get an idea how much data is required for the application.

 we-online.com/Adrastea-Commander

Proteus Connect App SDKs and source code for BLE

The Proteus Connect SDKs enable development of software applications for smart devices that connect and exchange data with BLE modules from Würth Elektronik eiSos. The Proteus Connect SDK is available for the following platforms:



Android
github.com/WurthElektronik/Proteus-Connect-Android



iOS
github.com/WurthElektronik/Proteus-Connect

Windows
github.com/WurthElektronik/Proteus-Windows-SDK



WÜRTH ELEKTRONIK MORE THAN YOU EXPECT

REDEXPERT



ONLINE PLATFORM
BASED ON MEASURED
VALUES

REDEXPERT The online platform of Würth Elektronik to select electronic and electromechanical components.

#REDEXPERT

- Online platform based on measured values
- The world's most accurate AC-loss model
- Filter settings for over 20 electrical and mechanical parameters
- Inductor simulation and selection for DC/DC converters
- Ability to compare inductance/current and temperature rise/DC current using interactive measurement curves
- Available in seven languages
- No login required
- Order free samples directly
- Direct access to product datasheets

www.we-online.com/redexpert

EVALUATION TOOLS

WIRELESS CONNECTIVITY



Evaluation Kit

The Evaluation Kit contains all necessary equipment like

- USB cable
- USB radio stick (if required)
- A 2nd evaluation board (for e.g. long range tests)
- Antennas (if external antenna configuration is chosen)

The included evaluation board offers the user the possibility to develop hard- and software for the compatible radio module. It can be connected to a USB port of a PC.

- Equipped with a multi-pin connector (which is connected to all pins of the RF module)
- Jumpers allow the module to be disconnected (from components such as the USB interface)



Mini/Family– Evaluation Board

The mini/family evaluation board is an intuitive, application oriented and cost effective version of the evaluation kit. It offers the possibility to develop hard- and software for the radio module.

- Not assembled with connectors and pin headers
- Intended for experienced developers

A PCB containing only one radio module to access all pins without any soldering effort. Can be used Plug&Play to connect a radio module directly to any host microcontroller by loose wires.

EVALUATION TOOLS

SENSORS

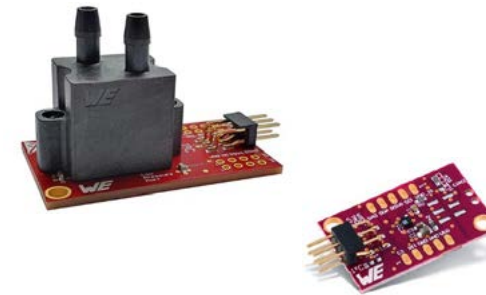

Evaluation Board

The evaluation board of the sensor provides an opportunity to verify the sensor performance and develop a prototype using an external processor.

- Can be directly plugged to another kit using the mounted I²C and SPI interface pins
- Can also be placed on a bread board using through hole pin header connections



Sensor Node

The sensor nodes function is to repeatedly read the respective sensor values via I²C and send them via Wirepas mesh network to a sink device. It contains:

- The Wirepas radio module Thetis-I
- Several Würth Elektronik eiSos sensors
 - WSEN-PADS
 - WSEN-HIDS
 - WSEN-TIDS
- CR2032 battery holder



FeatherWings

The selection of FeatherWings enables quick and easy prototyping as well as individual test setups. The FeatherWing development boards are open source and fully compatible with the Feather form factor.



USB Radio Stick

A USB radio stick consists of radio module along with a serial-to-USB adapter that enables direct connection to any USB compatible device. An FTDI serial-to-USB converter chip FT231X connects the USB interface of the radio stick to the UART pins of the integrated radio module.

- Including all necessary certification
- Can be used Plug&Play



Sensor Shield for Arduino

The evaluation board "Sensor Shield for Arduino" is a stackable extension board for the Arduino (UNO and DUE) board. It can be used to connect all sensor evaluation Boards:

- WSEN-HIDS
- WSEN-TIDS
- WSEN-ITDS
- WSEN-ISDS
- WSEN-PADS
- WSEN-PDUS



FeatherWing

The sensor FeatherWing enables quick and easy prototyping as well as individual test setups. Temperature, humidity, air pressure and 3 axis acceleration are recorded. The FeatherWing development boards are open source and fully compatible with the Feather form factor.

DISCOVER THE WORLD OF SENSORS



19

25

31

37

45

52

FUNDAMENTALS

What is a sensor component?

A system that measures a physical dimension and transfers into an electrical signal. Sensors are basically analog with infinite resolution, but data to and from the cloud is transferred digital. Analog sensor values must therefore be digitized. Conversion can be done in external AD converters when using an analog sensor cell or the conversion can be all done internally, within the sensor system, when using a MEMS sensor. Digital MEMS sensors help to save time, processor bandwidth and board space.

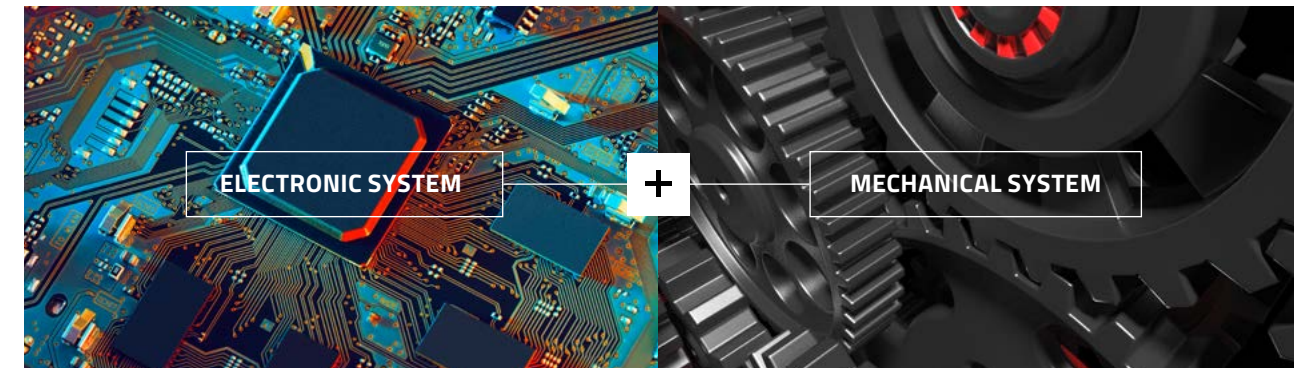

MEMS sensors

In a microcontroller the typical semiconductor can only control current and voltages. In a Micro-Electro-Mechanical System (MEMS), additional mechanical structures are used. This means that three-dimensional structures are usually added to the starting material silicon by etching processes. This allows the design of membranes (WSEN-PADS) or movable finger structures (WSEN-ITDS).

Combined sensors

Some sensors actually consist of multiple sensor elements in the same housing like the combined Humidity and Temperature sensor WSEN-HIDS or the combined Pressure and Temperature sensor WSEN-PADS.

This has advantages when:

- Space is at a premium (Diverse sensors in one housing require less space than single sensors)
- Power supply is limited (Multifunction sensors typically require less power than multiple single sensors)
- Price matters (a single, slightly larger, package is generally less expensive than several smaller ones.)
- Measurement accuracy must be improved (Short cable runs between the contained sensors are more easily shielded within a package than connections made to the outside.)
- Additional data can be calculated (in some cases, additional information can be calculated from measured values of combination sensors)

Additional Advantages of integrated sensors

- ✓ Surface mounted device (SMD)
- ✓ Silicon based
- ✓ Fully calibrated
- ✓ Integrated DSP
- ✓ Digital interface (I²C, SPI)

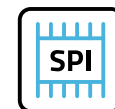
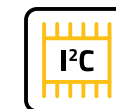

Longlife availability (10 years)

To avoid additional wiring in end device it is more and more common to replace the cables with wireless connectivity solutions like radio modules from Würth Elektronik. This requires especially sensors to be very energy-efficient, i.e. offering a very Low power consumption. With that achievement a wireless sensor network can be operated on battery by ten years and more.

Micro-Electro-Mechanical System - Unit (MEMS)

- Bulk- or surface micromachining to create mechanical structures
- Very small dimensions possible
- Able to detect very small changes in physical dimension

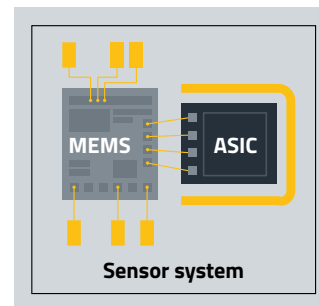

Application-Specific-Integrated Circuit - Unit (ASIC)

Analog front end:

- Amplifying the signal
- Multiplexing in case of different sensor elements
- Conversion from analog to digital value

Digital logic:

- Filtering
- Calibration, Compensation and linearization
- Registers and buffering

Interfaces:

- SPI/I²C – digital interface
- Interrupt /alert for special scenarios

Scale of integration

MEMS Cell

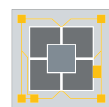

- Uncompensated
- Non-calibrated
- Analog (mV) output
- Bare-die or Packed

Amplified Sensor

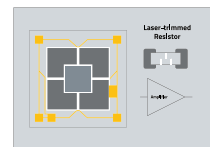

- Passively compensated
- Partly calibrated
- Analog output
- Packaged

Integrated Sensor

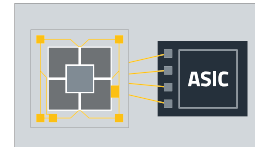

- Compensated over temperature
- Fully calibrated
- Integrated DSP & Memory
- Digital and Analog
- Packaged



From sensing cell ... to integrated sensor system

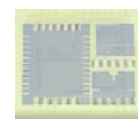

MEMS



ASIC



MEMS & ASIC Stack

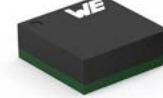

Sensor

Block Diagram

The best way to explain the function of MEMS sensors is through a block diagram. The biggest difference to conventional (analog) sensors is that not only the actual measuring cell but also the complete processing can be integrated to achieve a very small sensor system. This eliminates any analog data processing on application level and a digital signal can be used directly by a microcontroller. Since a complete system is combined in one component, a complete factory calibration is also possible.

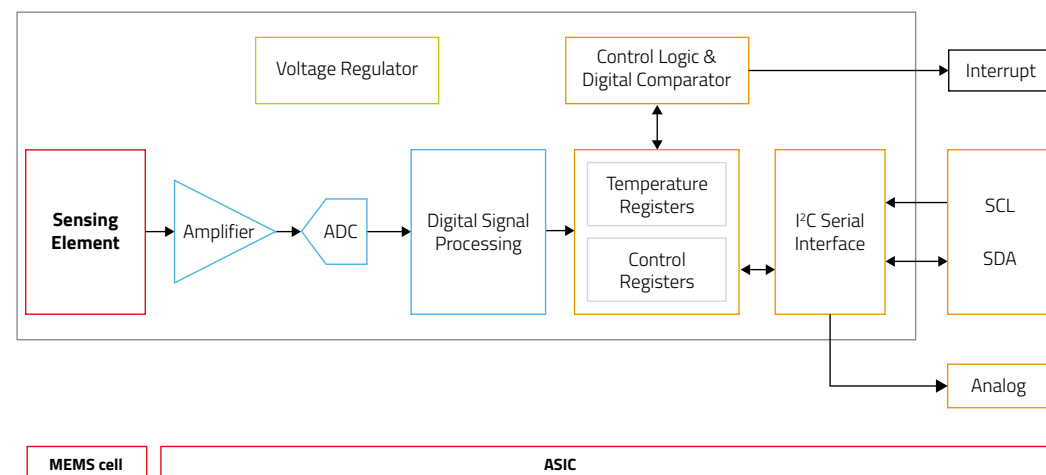

Sensor interfacing

How do I connect my sensor? → Work with standard communication protocols!

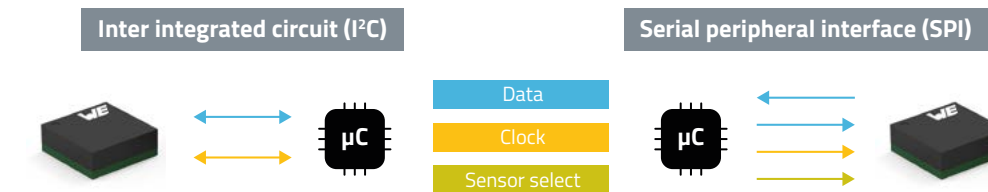

- 2 Wires
- Each sensor has own address
- Multiple sensors sequentially on the 2 lines
- Half-duplex
- ACK bit after each byte transfer – error detection
- Simpler wiring – easier to implement
- Lower power consumption

- 3/4 Wires
- Each sensor selected via a sensor select line
- High data transfer speed
- Full-duplex
- No error checking
- More complex wiring – higher pin count
- Higher power consumption

Comparison Analog vs Digital sensor

	Analog sensor	Digital sensor
Dimension	Mostly several parts needed, bigger formfactor	All-in-one, smaller formfactor
Costs	Several components like sensor, external resistors, stable voltage supply, ADC are needed	MEMS sensor covers the whole sensor system
Calibration	Field/system calibration needed (at multiple temperatures)	Off-the-shelf calibrated
Accuracy	System accuracy = sensor element + measuring circuitry	Sensor accuracy = System accuracy
Measuring	Mostly non-linear	Fully compensated and calibrated
Power Consumption	Voltage divider constantly drains power	Very low power, sleep mode between active sense cycles
Data Quality	Contact and load resistance as well as the absolute voltage supply level will have an influence on the accuracy. Additional inaccuracy based on the ADC has to be considered.	Stable output signal (digital value), additional possibilities to verify correct data transmission like parity or CRC. Also sensor status information can be sent.
Integration	External circuitry	Simple I/O pins with direct values from sensor

Different Modes for different Needs

Typically the mode selection is a tradeoff between current consumption and accuracy/noise.

- High performance mode with highest data rate
- Normal mode as a perfect compromise
- Low power mode with lowest power consumption

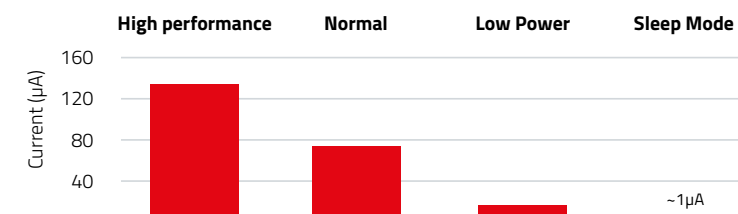

SENSOR GUIDE

How to find the suiting product?

This Sensor Guide will help you to find a solution for your application! Answer the following questions, as far as you to be able to take a decision.



If there is any need of support: Contact us!

wcs@we-online.com

1. Sensing medium	2. Interface	3. Environment	4. Accuracy Requirements	5. Characteristics requirements	6. Use Case / Application
<p>Which medium do you want to measure?</p> <p><input type="checkbox"/> Temperature</p> <p><input type="checkbox"/> Humidity</p> <p><input type="checkbox"/> Pressure absolute</p> <p><input type="checkbox"/> Pressure differential</p> <p><input type="checkbox"/> Acceleration</p> <p><input type="checkbox"/> Angular rate</p> <p><input type="checkbox"/> Current</p> <p><input type="checkbox"/> other: _____</p>	<p>Which interface do you want to use?</p> <p><input type="checkbox"/> I²C</p> <p><input type="checkbox"/> SPI</p> <p><input type="checkbox"/> Analog</p> <p><input type="checkbox"/> other: _____</p>	<p>In which environment will your application be used?</p> <p><input type="checkbox"/> Indoor</p> <p><input type="checkbox"/> Outdoor</p> <p><input type="checkbox"/> Industrial</p> <p><input type="checkbox"/> Home Automation</p> <p><input type="checkbox"/> other: _____</p>	<p>What are the key requirements for the accuracy of the sensor?</p> <p><input type="checkbox"/> High accuracy: _____</p> <p><input type="checkbox"/> Medium accuracy: _____</p> <p><input type="checkbox"/> Accuracy doesn't matter</p> <p><input type="checkbox"/> other: _____</p>	<p>What are the additional requirements for the characteristics of the sensor?</p> <p><input type="checkbox"/> Energy consumption: _____</p> <p><input type="checkbox"/> Operating supply voltage: _____</p> <p><input type="checkbox"/> Output data rate: _____</p> <p><input type="checkbox"/> Size: _____</p> <p><input type="checkbox"/> Media resistance: _____</p> <p><input type="checkbox"/> other: _____</p>	<p>What is the use case / the application of the sensor element / sensor system?</p> <p><input type="checkbox"/> Sensor network</p> <p><input type="checkbox"/> Environment measuring</p> <p><input type="checkbox"/> Process control / automation</p> <p><input type="checkbox"/> Redundancy</p> <p><input type="checkbox"/> Event triggering / decision support</p> <p><input type="checkbox"/> other: _____</p>



MOTION SENSORS



FUNDAMENTALS

Motion sensors play a crucial role in modern technology, enabling a wide range of applications across various industries. These sensors are designed to measure and detect changes in motion, providing essential data for navigation, orientation, and control systems. The primary types of motion sensors include accelerometers and gyroscopes, which collectively contribute to a device's ability to understand and respond to changes in its position and movement.

Accelerometers, designed to gauge changes in linear acceleration, empower devices to discern movements, vibrations, and tilts along multiple axes. They are typically based on microelectromechanical systems (MEMS) technology, utilizing tiny, suspended structures that move in response to acceleration forces.

On the other hand, gyroscopes focus on measuring angular velocity, providing insights into an object's rotational motion. MEMS-based gyroscopes use the Coriolis effect, where a vibrating structure experiences a force perpendicular to its motion when the device rotates. When combined, these sensors form a powerful duo capable of delivering comprehensive data on linear motion in three axes and rotational movements along three axes, commonly referred to as six degrees of freedom (6-DOF). They are also referred to as 6-axis IMU (Inertial Measurement Unit). Integration of a 3-axis Magnetometer into the combination of 3-axis Accelerometer and 3-axis Gyroscope result in a 9-axis IMU. Our product portfolio offers 3-axis Accelerometer and 6-axis IMU (Accelerometer + Gyroscope).

Working principle of a MEMS Acceleration Sensor

The sensor is a MEMS based capacitive acceleration sensor with an integrated ASIC. The acceleration sensors production approach is the creation of finger structures. One side is fixed, the other side is flexibly suspended. The sensor measures the acceleration or vibration through MEMS capacitive sensing principle. If this system gets accelerated, the distance changes between the fixed and movable structure. This change in distance causes a change in the electrical capacitance (capacitor principle), which could be measured electrically and serves as a reference value for acceleration.

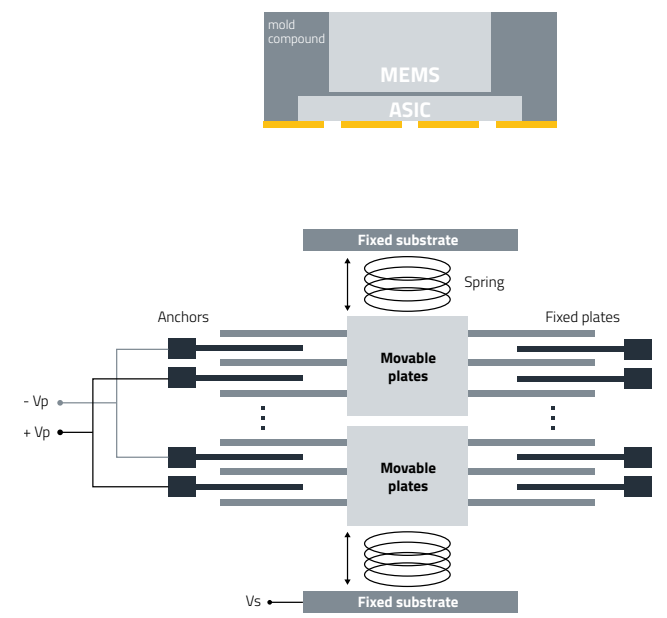

Working principle of MEMS Gyroscope

The MEMS Gyroscope consists of a suspended proof mass, a driving system to oscillate the proof mass, and a sensing system. An angular rotation along one axis will result in a Coriolis force along another axis. The Coriolis force (F) causes a displacement, and it is proportional to the angular rotation on the original axis. Displacement is calculated by measuring the change in capacitance.

For example, an angular rotation along the Z-axis causes Coriolis force on the Y-axis resulting in a displacement of the proof mass and a change in capacitance. The capacitive sensing interface detects this displacement.

A tuning fork configuration is used in our MEMS gyroscopes to make the sensor's operation independent of linear accelerations.

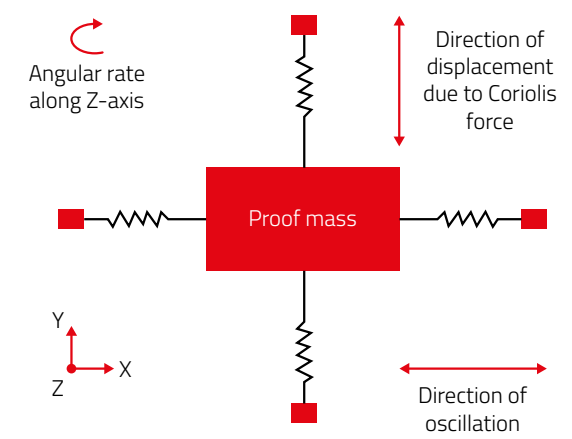

25

26

PRODUCTS

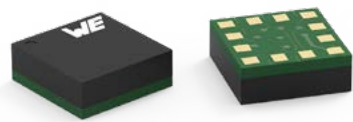

WSEN-ITDS 3 Axis Acceleration Sensor

Product Features

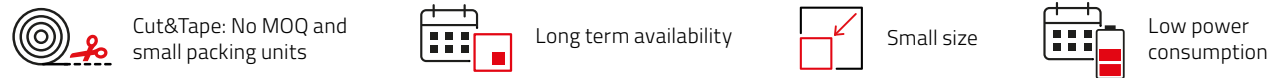

- MEMS based capacitive sensing principle
- 14 bit output resolution
- Full scale $\pm 2\text{ g}$, $\pm 4\text{ g}$, $\pm 8\text{ g}$, $\pm 16\text{ g}$
- Output data rate up to 1600 Hz
- 32 level FIFO buffer
- Size: $2 \times 2 \times 0.7\text{ mm}$
- Embedded temperature sensor
- I²C and SPI communication interface
- Temperature range: $-40\text{ }^\circ\text{C}$ up to $+85\text{ }^\circ\text{C}$

Order Code	a_{RANGE}	RES _a (bits)	ODR _{max} (Hz)	f _{BW} (Hz)	V _{DD min} (V)	V _{DD max} (V)
2533020201601	$\pm 2 / \pm 4 / \pm 8 / \pm 16\text{ g}$	14	1600	400	1.7	3.6

a_{RANGE} : Acceleration range [typ.]; RES_a: Resolution [max.]; ODR_{max}: Output data rate [max.]; f_{BW}: Bandwidth [max.]; V_{DD min}: Operating supply voltage [min.]; V_{DD max}: Operating supply voltage [max.]

Block Diagram

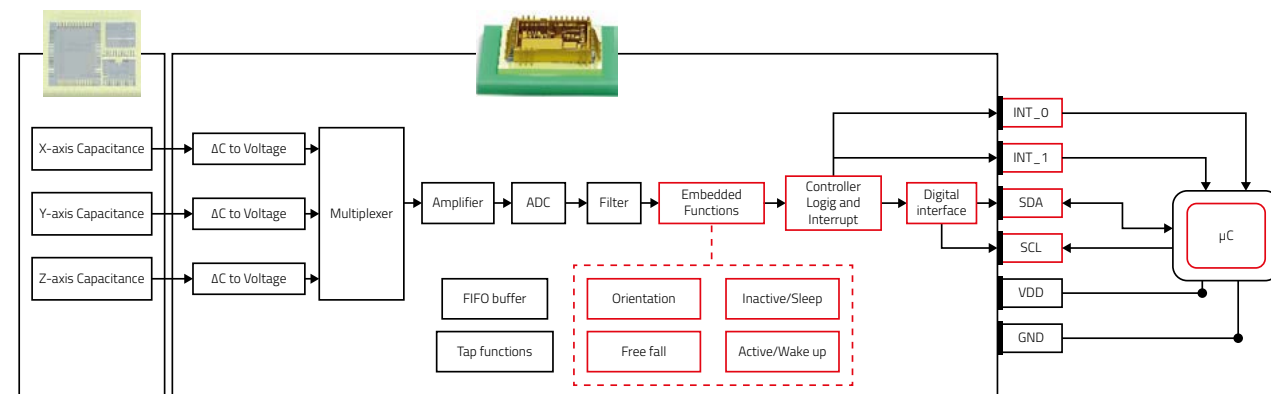

Automatic operating mode change for low battery power application

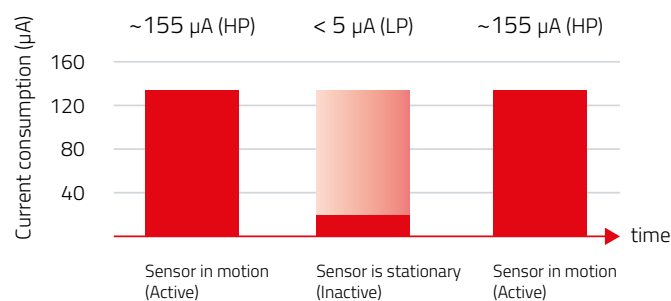

Embedded Functions

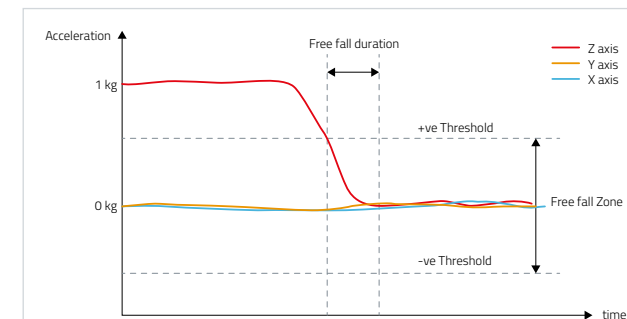

Free fall

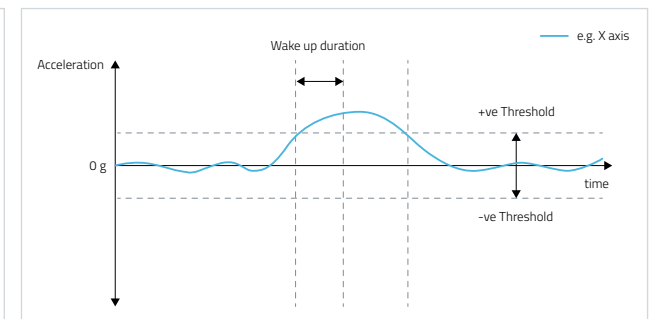

Sleep and wake up

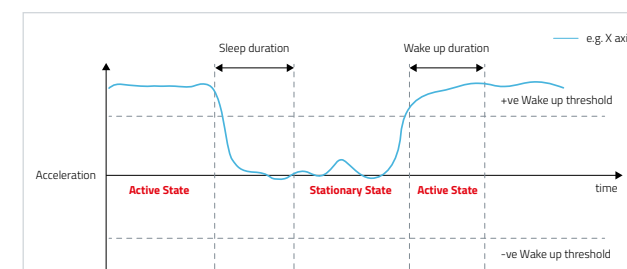

Stationary/Active

Application: Low Vibration detection – Bandwidth as a key factor

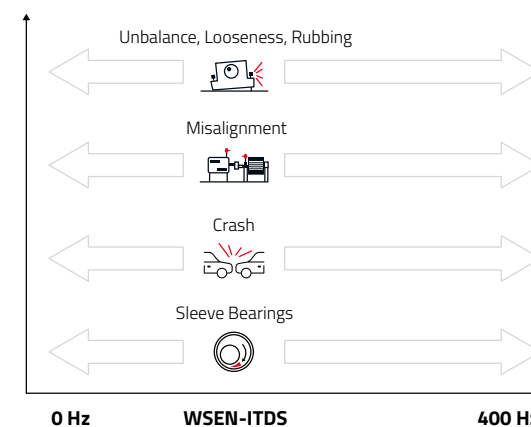

Bandwidth cutoff frequency at 400 Hz

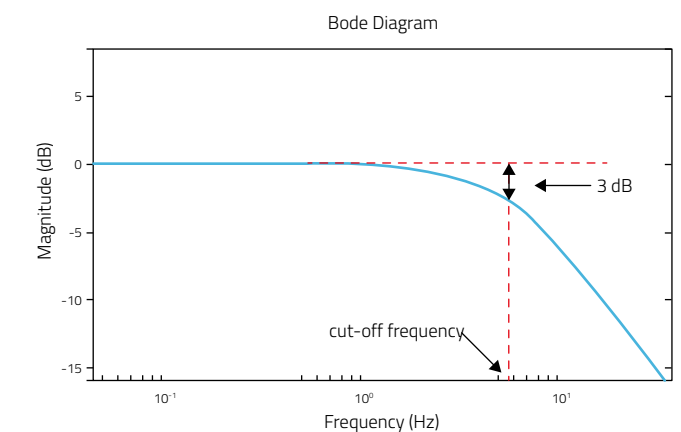

WSEN-ITDS:
we-online.com/WSEN-ITDS



Webinar:

Accelerate your IoT development project with our MEMS 3-axis sensor



PRODUCTS

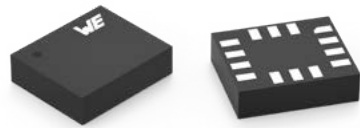

WSEN-ISDS 6 Axis IMU (3 Axis Accelerometer + 3 Axis Gyroscope)

Product Features

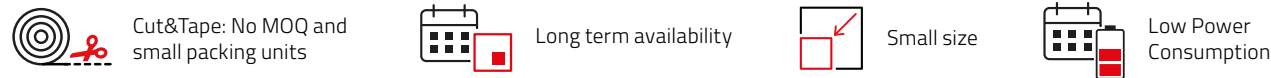

- MEMS based capacitive sensing principle
- Application specific functionality: Free-fall, wake-up, tap, activity, motion, tilt and orientation detection
- Fully calibrated 16 bit output
- Acceleration full scale: $\pm 2g$, $\pm 4g$, $\pm 8g$, $\pm 16g$
- Output data rate: 6.6 kHz
- Size: $3 \times 2.5 \times 0.86$ mm
- Gyroscope full scale: ± 125 dps up to ± 2000 dps
- Embedded temperature sensor
- Temperature range: -40 °C up to $+85$ °C
- I²C and SPI digital communication interface

Order Code	Sensor	Selectable Ranges	ODR _{MAX} (Hz)	f _{BW} (Hz)	V _{DD MIN} (V)	V _{DD MAX} (V)	RES _T (bits)
2536030320001	Accelerometer	$\pm 2g$, $\pm 4g$, $\pm 8g$, $\pm 16g$	6664	1400	1.7	3.6	16
	Gyroscope	± 125 dps ± 250 dps ± 500 dps ± 1000 dps ± 2000 dps	6664	937			

ODR_{MAX} (Hz): Output data rate [max.]; f_{BW} (Hz): Bandwidth [max.]; V_{DD MIN} (V): Operating supply voltage [min.]; V_{DD MAX} (V): Operating supply voltage [max.]; RES_T (bits): Resolution [typ.]

Block Diagram

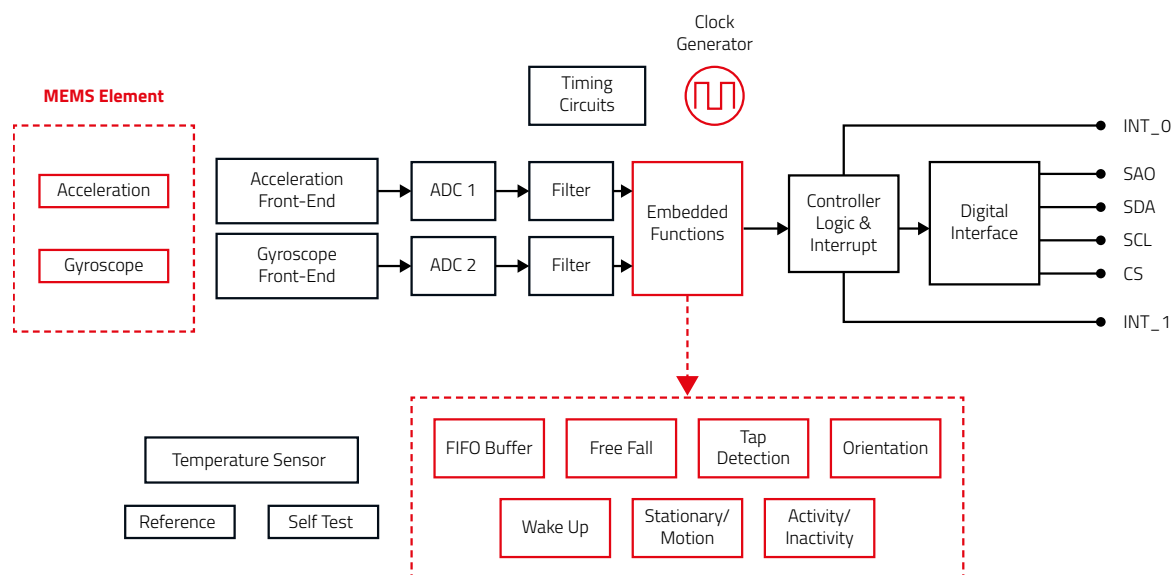

Tilt detection process

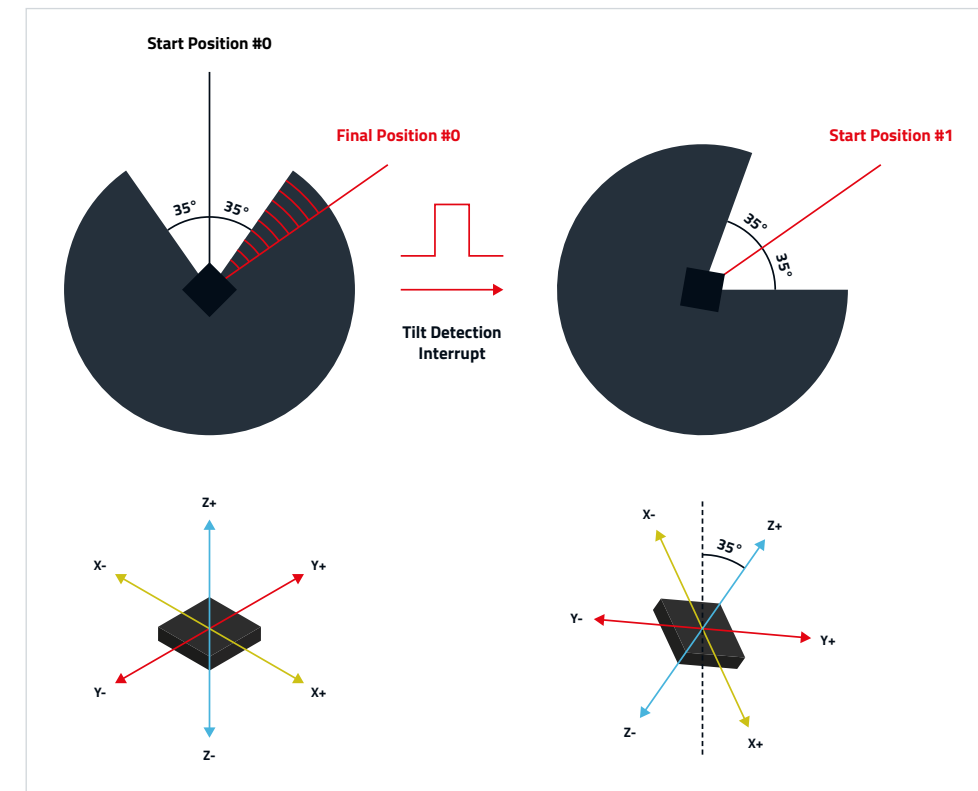

FIFO (First-In-First-Out) Buffer

- WSEN-ISDS consists of a FIFO buffer, which is a memory storage system used for sequential data storage and retrieval, ensuring that the first data inputted is the first to be retrieved.
- FIFO buffers ensure data integrity, lossless data capture, time synchronization, and efficient handling of burst data, reducing processing overhead and providing temporary storage for uninterrupted operation.
- The FIFO buffer can be operated in different modes and can be configured according to the user's requirement by adjusting the register values.

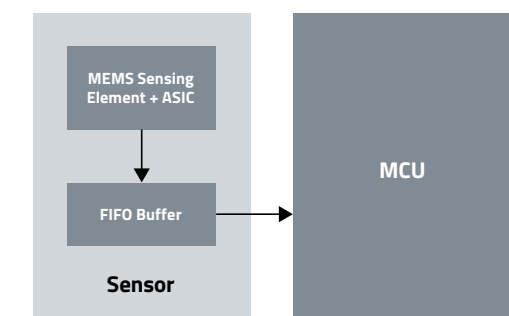

Flow of data using FIFO Buffer



WSEN-ISDS:
we-online.com/WSEN-ISDS



Webinar:

Increase the senses with our 6 axis IMU





ENVIRONMENTAL SENSORS





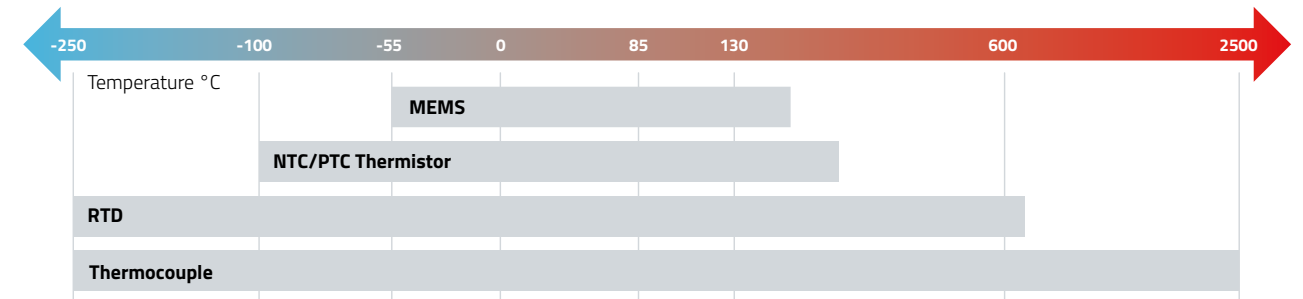

FUNDAMENTALS

Ever wondered what's truly happening in your environment? Go beyond the surface with environmental sensors, your window into the invisible world around you. These cutting-edge devices act as your eyes and ears, measuring and recording crucial environmental data. Temperature and Humidity are one of the most measured entities in the environment. Introducing our Environmental Sensor Family, a comprehensive solution that seamlessly integrates humidity and temperature sensors to enhance your environmental monitoring capabilities. These sensors are crafted with precision to deliver accurate and timely measurements, allowing users to gain a thorough understanding of their surroundings. Whether applied in residential, industrial, or research settings, our Environmental Sensor Family ensures that you have the essential data on humidity and temperature at your fingertips, enabling informed decisions for a more sustainable and efficient environment.

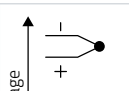
Temperature Sensors

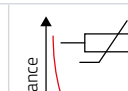

	WSEN-TIDS			
				
	Thermocouple	RTD (Resistive Thermo-Device)	Thermistor (thermal resistor)	MEMS
Measurement range	-250 °C to 2500 °C	-250 °C to 700 °C	-100 °C to 250 °C	-55 °C to 150 °C
Accuracy	Average (require CJC)	Highest	Average	High
Sensitivity	Low-average	Average	High	High
Linearity	Average	Good	Low	Highest
Peripheral Circuits/Calibration	CJC; Amplifier; Scaling	Resistance correction; Scaling	Scaling	No
Footprint	Large	Medium	Small	Smallest
Price	Moderate	Very high	Low	Low

CJC= Cold Junction Compensation → Reference Calibration

Humidity Sensors

Humidity
The amount of moisture or water vapor present in the air.

Relative Humidity
The amount of water in the air compared to the amount of water the air could hold at the present temperature.
Unit: %rH

Absolute Humidity
The actual amount of water vapor present in the air, irrespective of the temperature.
Unit: g/m³

Specific Humidity
The amount of water vapor present in the air per unit mass of air.

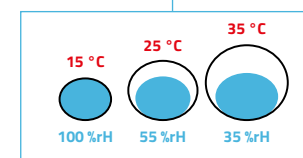

31

32

PRODUCTS



WSEN-TIDS Temperature Sensor IC

Product Features

- Cut&Tape: No MOQ and small packing units
- Long term availability
- Small size
- Low Power Consumption

- Silicon based digital temperature sensor
- High accuracy (up to ± 0.25 °C typ.)
- Fully calibrated 16 bit temperature output
- Low current consumption of 1.75 μ A typ
- Size: 2 x 2 x 0.55 mm
- Selectable output data rate up to 200 Hz
- I²C digital communication interface
- Programmable temperature threshold and interrupt
- 2 selectable I²C addresses

Order Code	T _{RANGE min} (°C)	T _{RANGE max} (°C)	RES _T (bits)	ODR _{min} (Hz)	ODR _{max} (Hz)	V _{DD min} (V)	V _{DD max} (V)
2521020222501	-40	125	16	25	200	1.5	3.6

T_{RANGE}: Measurement range [min.]; RES_T: Resolution [typ.]; ODR_{min}: Output data rate [min.]; ODR_{max}: Output data rate [max.]; V_{DD min}: Operating supply voltage [min.]; V_{DD max}: Operating supply voltage [max.]

Si-based Temperature Sensor - Principle

BJT = Bipolar Junction Transistor

Forward voltage of a Si-diode is temperature dependent
→ Base-emitter junction of a BJT

FW Voltage

Temperature

Two BJTs with different currents

I₁, I₂

Q₁, Q₂

ΔV_{BE}

V_{CC}

Difference of Voltage proportional to the Temperature

In the next steps... Amplification, ADC, Calibration...

Block Diagram

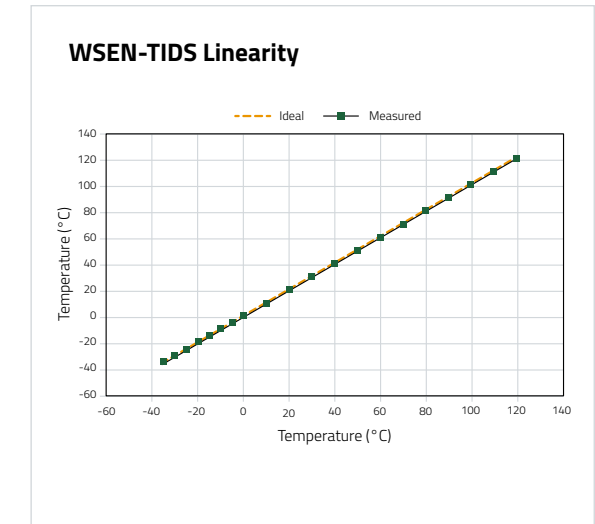
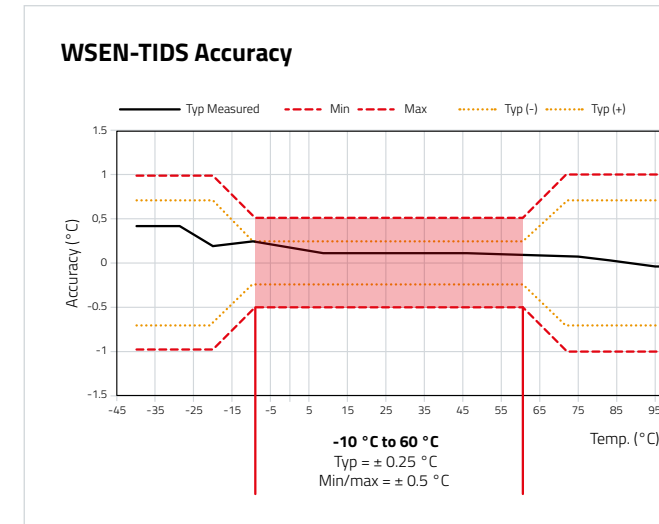
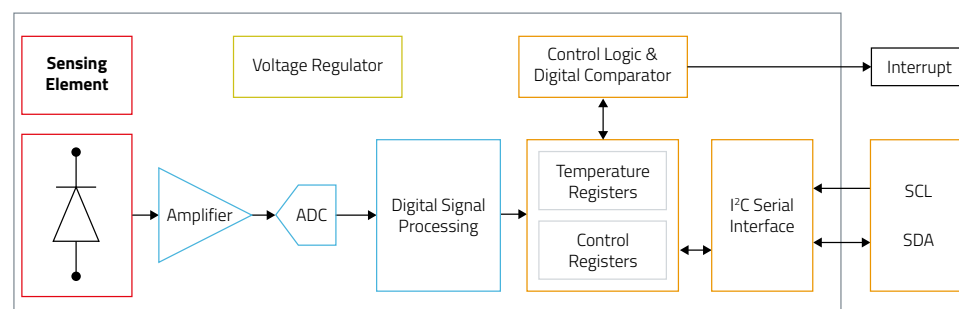

Mounting examples based on application

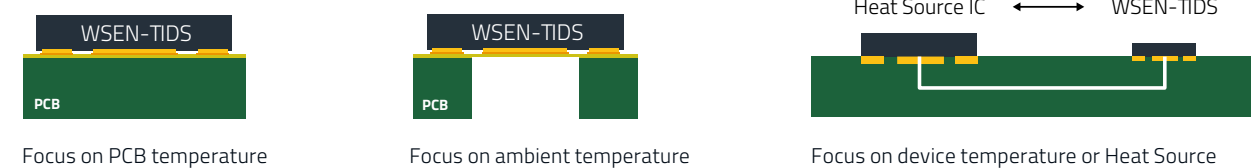

Power saving through interrupt output

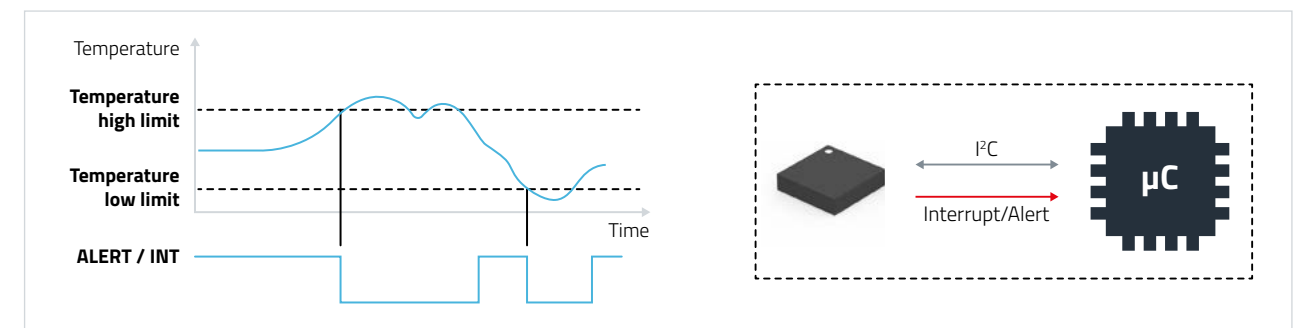

WSEN-TIDS:
www.we-online.com/WSEN-TIDS



Webinar:
Digital silicon-based temperature sensors for industrial applications



PRODUCTS

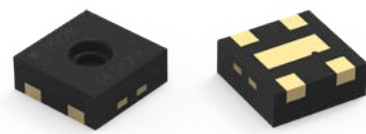

WSEN-HIDS Humidity Sensor with integrated Temperature Sensor

Product Features



- MEMS based capacitive sensing principle
- Relative humidity range 0% to 100%
- Humidity accuracy: $\pm 1.8\%$ rH, (20 to 80% rH); $\pm 3\%$ rH, (0 to 100% rH)
- Fully calibrated 16 bit humidity and temperature output
- Size: 1.5 x 1.5 x 0.5 mm
- I²C communication interface
- Selectable output data rate up to 1 Hz
- Operating temperature range: -40 °C to 125 °C
- Temperature accuracy T_{ACC} : ± 0.2 - ± 0.6 °C

Order Code	H _{RANGE min} (% rH)	H _{RANGE max} (% rH)	H _{ACC} (°C)	T _{RANGE min} (°C)	T _{RANGE max} (°C)	T _{ACC_ABS} (°C)	V _{DD min} (V)	V _{DD max} (V)
2525020210002	0	100	$\pm 1.8\%$ rH	-40	125	± 0.2 °C	1.08	3.6

H_{RANGE min} - Humidity range [min]; H_{RANGE max} - Humidity range [max]; T_{RANGE min} - Temperature range [min]; T_{RANGE max} - Temperature range [max]; T_{ACC_ABS} - Temperature accuracy Operating supply voltage [min.]; V_{DD max}: Operating supply voltage [max.]

Working Principle

- Capacitive Sensing technology
- The humidity sensor is a small capacitor consisting of a hygroscopic dielectric material placed between a pair of electrodes. The change in the humidity in atmosphere will affect the dielectric constant which results in change in the capacitance represents the moisture % in atmosphere
- Integrated heater to remove condensed water on sensor surface

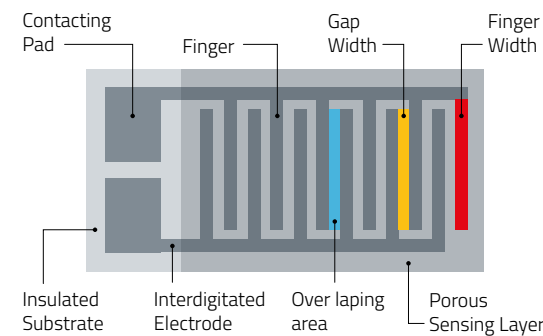

$$Capacitance = \epsilon_r \epsilon_0 \frac{A}{d} \text{ (Farad)}$$



Block Diagram

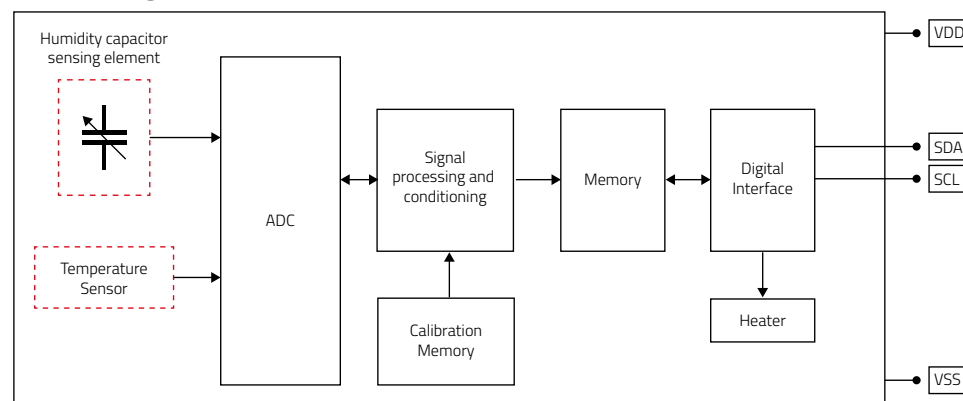

Humidity Sensor

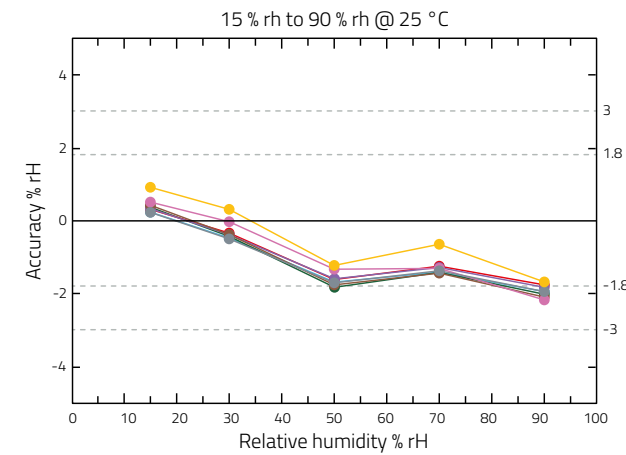

Humidity Sensor accuracy

Measurement Range	Test Condition	Accuracy
0 - 100 % rH	20 % rH to 80 % rH	$\pm 1.8\%$ rH
	0 % rH to 100 % rH	$\pm 3\%$ rH

Temperature Sensor

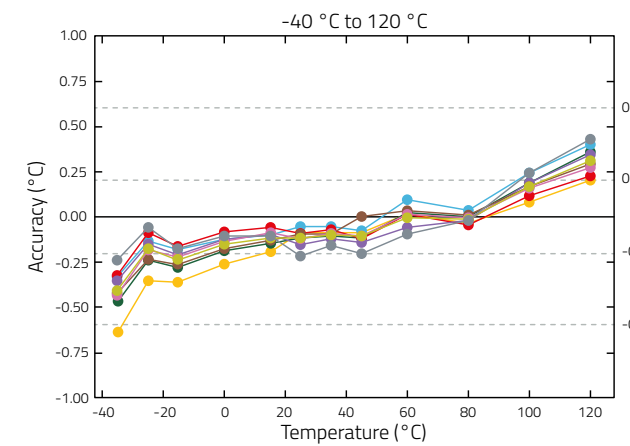

Temperature Sensor accuracy

Measurement Range	Test Condition	Accuracy
-40 °C - 125 °C	0 °C to 60 °C	± 0.2 °C
	-40 °C to 125 °C	± 0.6 °C

PCB layout recommendations

The combined Humidity and Temperature Sensor is high is very sensitive to the environment. Therefore it is recommended to follow the design guidelines strictly. Details can be found in our Application Note.

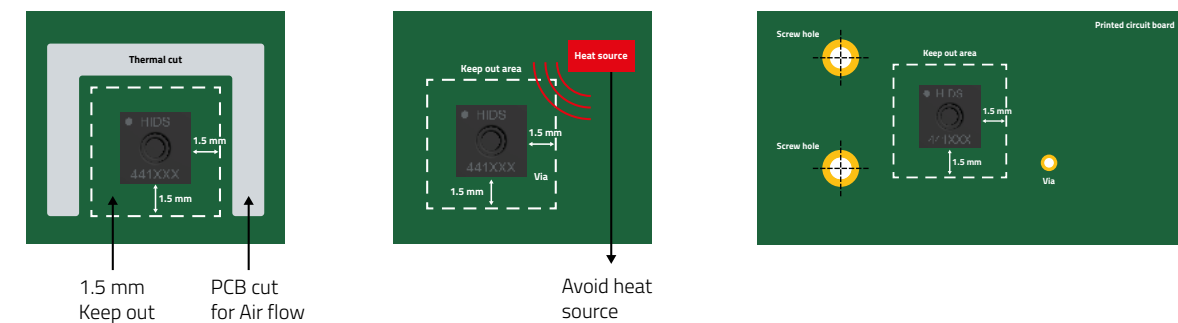



PRESSURE SENSORS



FUNDAMENTALS

Functionality of a MEMS Pressure Sensor

A MEMS pressure sensor is based on a thin membrane. Typically two principles are used. The first principle is based on a change in resistance of integrated resistors caused by the deflection of the membrane. The second principle is based on a capacitive effect: a counter electrode is located below the membrane and based on the deflection of the membrane, the distance and thus the capacitance is changed. WSEN-PADS and WSEN-PDUS are based on piezo-resistive principle.

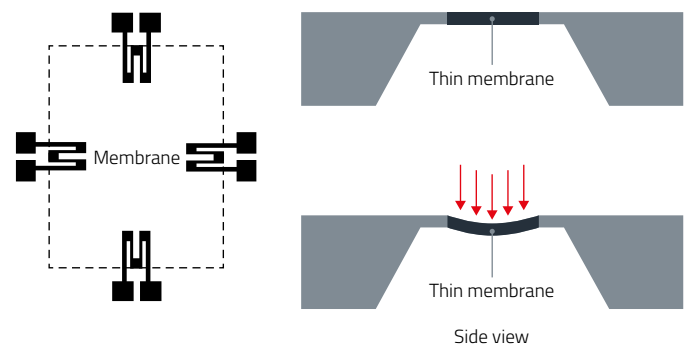

Source: <https://www.radiolocman.com/review/article.html?id=148185>

A MEMS pressure sensor is more expensive in comparison to a MEMS Acceleration Sensor due to:

- Direct contact to the environment
- Packaging is more complex

Which pressure sensor do I need?

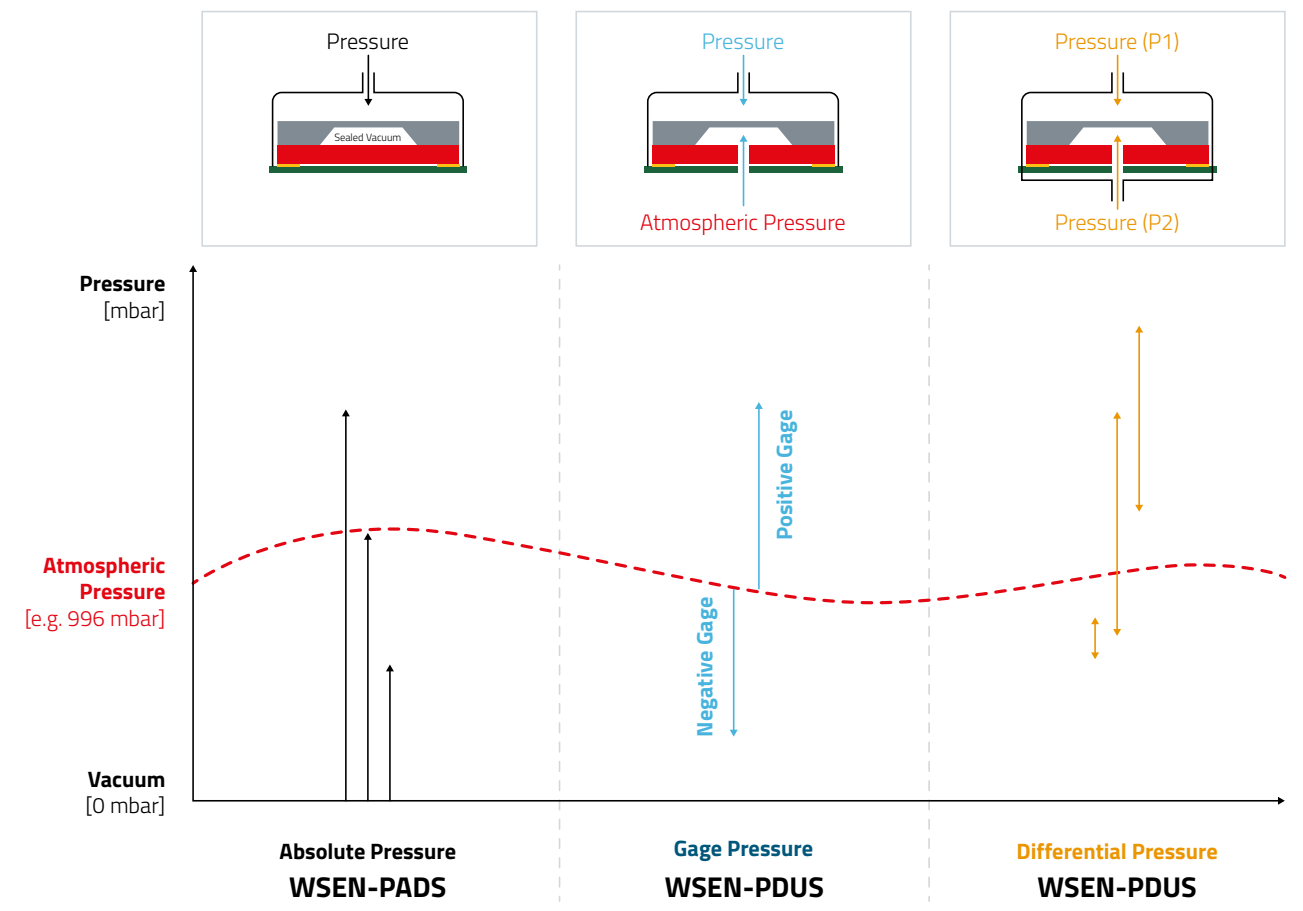

37

38

PRODUCTS

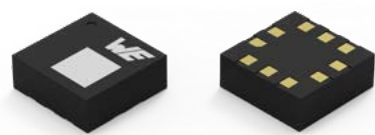

WSEN-PADS Absolute Pressure Sensor

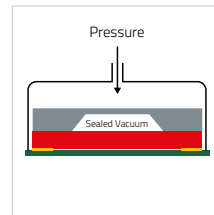

Product Features

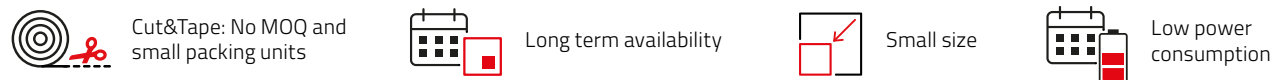

- MEMS based piezo-resistive sensing principle
- 24 bit pressure output resolution
- Selectable output data rate up to 200 Hz
- 128 level FIFO buffer
- Low current consumption of 0.9 µA typ.
- Size: 2 x 2 x 0.8 mm
- Embedded temperature sensor
- I²C and SPI communication interface
- Application specific interrupt event setting
- Temperature range: -40 °C up to +85 °C (16-bits)
- ±1 mbar absolute accuracy

Order Code	P _{RANGE min} (kPa)	P _{RANGE max} (kPa)	RES _p (bits)	ODR _{min} (Hz)	ODR _{max} (Hz)	V _{DD min} (V)	V _{DD max} (V)
2511020213301	26	126	24	1	200	1.7	3.6

P_{RANGE min}: Measurement range [min.]; P_{RANGE max}: Measurement range [max.]; RES_p: Resolution (ADC) [typ.]; ODR_{min}: Output data rate [min.]; ODR_{max}: Output data rate [max.]; V_{DD min}: Operating supply voltage [min.]; V_{DD max}: Operating supply voltage [max.]

Block Diagram

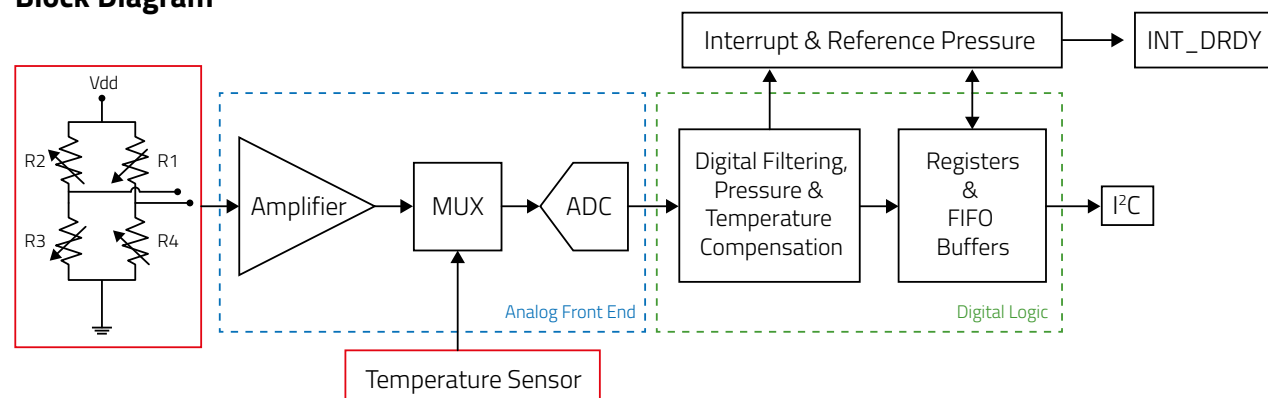

Additional advantages of the integrated sensor

- Fully molded package
- Increased robustness
- Contamination risk reduced
- Improved moisture and dust resistance
- Multiple vent holes

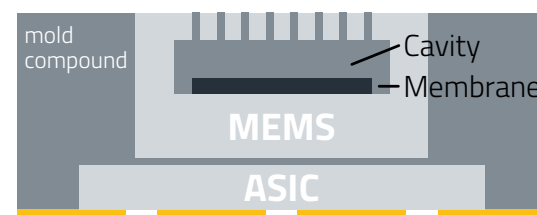

Is WSEN-PADS suitable for my application?

This absolute pressure sensor is housed in a small package suitable for surface mounting on a printed circuit board (PCB). That's why the WSEN-PADS is also known as a board-level sensor. This makes it ideal for consumer applications where the pressure on the PCB can be measured, e.g. B. in an altimeter or a sports watch, but this sensor is not suitable for the high temperatures of liquids or gases. It is also not adequately protected against dust, moisture or the chemicals commonly used for cleaning in industry. Industrial sensors are usually robustly packaged. They are usually made of corrosion-resistant material such as stainless steel and are threaded so they can be attached to pipes and storage tanks.

WSEN-PADS for Altitude measurements

An altimeter is an instrument that measures the height/altitude above a fixed level. Almost linear co-relation between the atmospheric pressure and the altitude enables the use of absolute pressure sensors as Altimeters. With the Built-in features like filters, offset calibration, temperature compensation etc., WSEN-PADS acts as a precise Altimeters and could be even used for indoor applications like, building height and floor detection.

Relationship between atmospheric pressure and altitude

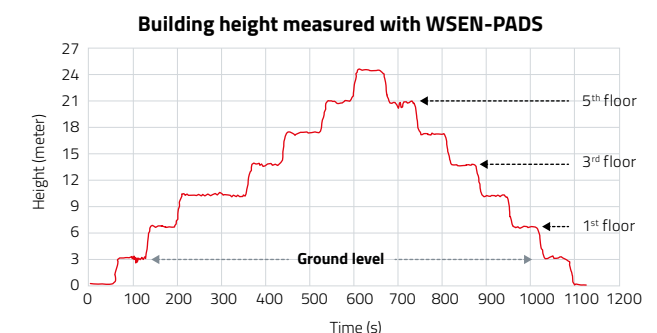
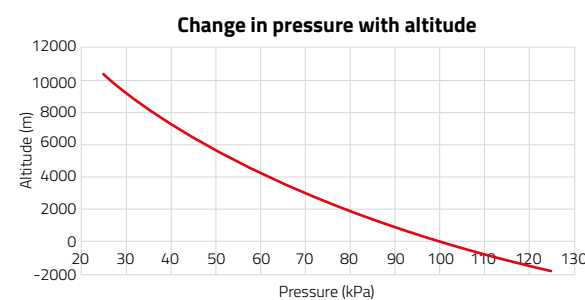

$$h = 44330.77 \times \left[1 - \left(\frac{P}{P_0} \right)^{0.256} \right]$$

H = Altitude
P = Pressure at altitude h
P₀ = Pressure at sea level or reference

- Indoor Navigation
- Floor detection
- Drone's: Maintaining constant altitude



WSEN-PADS:
www.WSEN-PADS



Webinar:

Currently under pressure? Discover our new MEMS pressure sensors



PRODUCTS

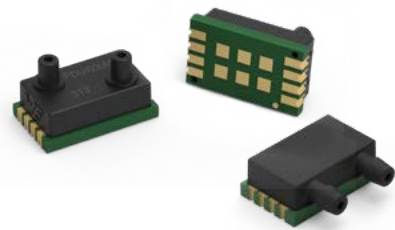

WSEN-PDUS Differential Pressure Sensor

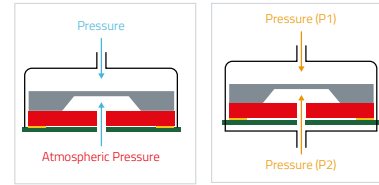

Product Features

- Cut&Tape: No MOQ and small packing units
- Long term availability
- Small size
- Custom calibration values possible

- MEMS based piezo-resistive sensing principle
- Very high accuracy (up to $\pm 0.25\%$ FSS tolerance)
- Different transfer functions from ± 0.1 kPa to 1 MPa
- 15 bit digital & 11 bit analog pressure output resolution
- Size: 13.8 x 8 x 7.55 mm
- Embedded temperature sensor
- Analog & I²C digital communication interface
- Temperature range: -25 °C up to +85 °C

Order Code	P _{RANGE min} (kPa)	P _{RANGE max} (kPa)	ACC _{P-TOT}	V _{DD min} (V)	V _{DD max} (V)	Nozzles
2513130810001	-0.1	0.1	$\pm 2.5\%$ FSS	4.75	5.25	vertical straight
2513130810101	-1	1	$\pm 0.75\%$ FSS	4.75	5.25	vertical straight
2513130810102	-1	1	$\pm 0.75\%$ FSS	3	3.6	horizontal
2513130810201	-10	10	$\pm 0.75\%$ FSS	4.75	5.25	vertical straight
2513130810301	0	100	$\pm 0.25\%$ FSS	4.75	5.25	vertical straight
2513130810302	0	100	$\pm 0.25\%$ FSS	3	3.6	vertical straight
2513130810401	-100	1000	$\pm 0.25\%$ FSS	4.75	5.25	vertical straight
2513130810402	-100	1000	$\pm 0.25\%$ FSS	3	3.6	vertical straight
2513130815401	0	1500	$\pm 0.25\%$ FSS	4.75	5.25	vertical straight

P_{RANGE min}: Measurement range [min.]; P_{RANGE max}: Measurement range [max.]; ACC_{P-TOT}: Total accuracy [typ.]; V_{DD min}: Operating supply voltage [min.]; V_{DD max}: Operating supply voltage [max.]

Construction compared to Absolute Pressure

- The sensor package is a bit different from the absolute pressure sensor. It has two pressure ports on the topside. Port P1 is exposed to the top side of the MEMS sensing element.
- The MEMS sensing element is placed on a ceramic substrate. Silicon and the Ceramic have a similar temperature co-efficient, hence thermal stress can be minimized. This significantly improves the Mechanical stability of the MEMS. For the reference pressure P2, a pneumatic channel is embedded inside the PCB of the sensor. It comes in a reflow solderable SMD package.

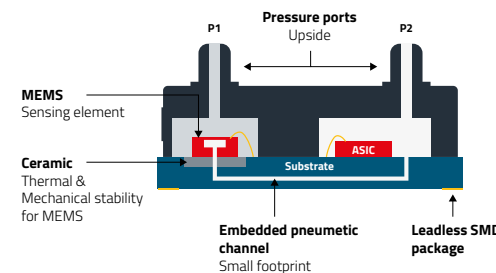

Block Diagram

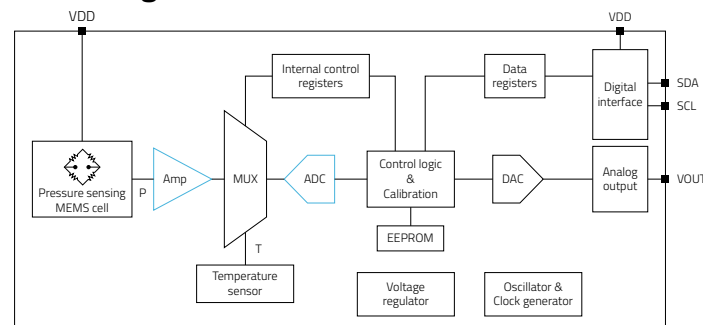

Conversion Table

1	Pa			0.01	mBar
2.5	Pa			0.025	mBar
10	Pa			0.1	mBar
0.1	kPa	1	hPa	1	mBar
1	kPa	10	hPa	10	mBar
10	kPa	100	hPa	100	mBar
26	kPa	260	hPa	260	mBar
100	kPa	1000	hPa	1	Bar
126	kPa	1260	hPa	1.26	Bar
1000	kPa	10,000	hPa	10	Bar

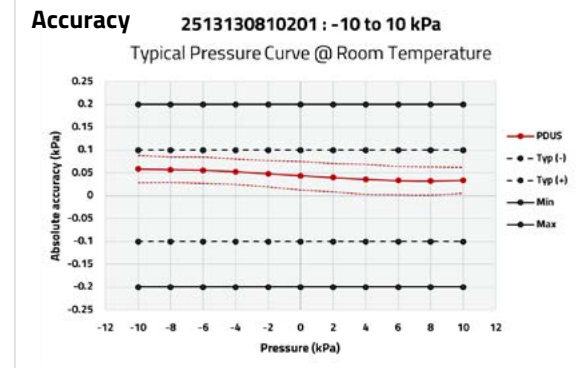

Package variants

1. Vertical straight nozzles



Ideal for manifold mounting

Advantage: Manifold mounting (i.e. adapter or housing) reduces the mechanical stress on the sensor as well as on the solder joints. This is especially important for the longevity of the sensors when they are used in high pressure (above 200 kPa) applications

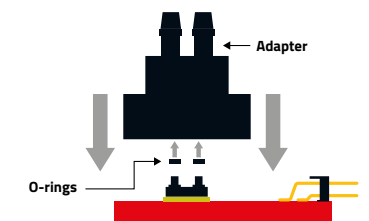

2. Horizontal barbed nozzle



Pneumatic tubes with inner diameter 2 mm could be directly connected

Tubes for Adapter: Inner diameter 4 mm; **Tubes for Sensor:** Inner diameter 2mm

Advantage:

Barbed connections allow for a straightforward push-in connection of pneumatic tubes and cannot be easily disconnected.

Adapters available

2500281615401	Adapter, o-rings, mounting material
2500281615402	Adapter, o-rings

Typical Application - Heating, Ventilation and Air Conditioning (HVAC)

Air Filter Monitoring

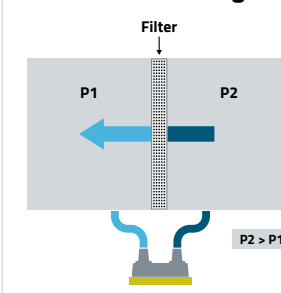

P1 = P2 → No Filter or Clean Filter

P2 > P1 → Clean Filter (Pre-defined)

P2 >> P1 → Change Filter Alert

Ventilator & Fan Control

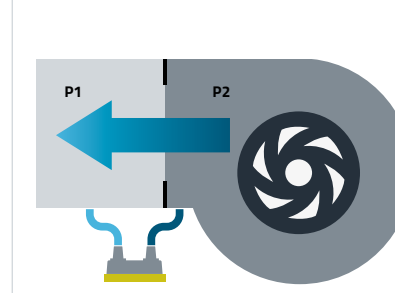

Air Pressure Control

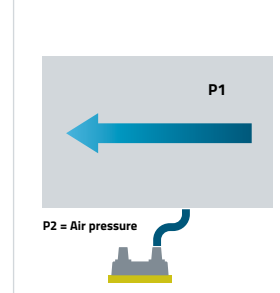

WSEN-PDUS CUSTOM OPTIONS

Standard Solution

Standard solution already covers an extensive pressure range, however, this might not be enough for some specific application. For example, an application requires a pressure range from 0 to 4 bar where the system operates on 3.3V supply voltage. Within our standard solutions, the pressure range of -1 to 10 bar would meet the pressure requirement, but it cannot work on 3.3 V supply voltage. With our individualization services, we are able to provide a sensor with operating pressure 0 to 4 bar and supply voltage 3.3 V. Along with the pressure range and supply voltage, many other parameters like communication interface, ADC resolution etc. can also be individualized. Packaging variants with barbed nozzles are also available for the applications where the pneumatic tubes need to be attached directly to the sensor

STANDARD Differential Pressure Sensor

- ✓ Nine different pressure ranges with fixed configuration are available
- ✓ These parts are always available ex-stock.

Standard Pressure Ranges

LOW	MEDIUM	HIGH
± 0.1 kPa ± 1 kPa	± 10 kPa 0 to 100 kPa	-100 to 1000 kPa 0 to 1500 kPa

Standard Features

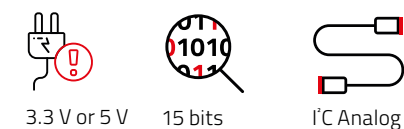

INDIVIDUALIZED Differential Pressure Sensor

- ✓ Customer defines pressure range of the final sensor between -1 bar (-100 kPa) to 15 bar (1500 kPa)
- ✓ Sensor will have a unique part number
- ✓ 100% calibrated, verified and tested

Exemplary Pressure Ranges

LOW	MEDIUM	HIGH
± 2 kPa 0 to 2 kPa	± 50 kPa 0 to 200 kPa	-100 to 700 kPa 0 to 1200 kPa

Additional Features

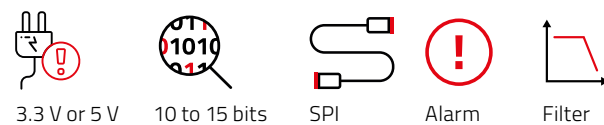

Additional Features that can be individualized

- Get the suitable supply voltage for your application
- Output resolution between 10 and 15 bits
 - Higher: High Accuracy, but slower response time
 - Lower: Low accuracy, but faster response time
- Noise reduction of output signal through filter
- Select the required digital communication interface supported by your host microcontroller additionally to the analogue output
- Create an interrupt/alarm signal based on a pre-configured pressure threshold for power saving

Individualize your sensor

Select one from each category. Digital and Analog voltage communication can be chosen together.

1. PRESSURE RANGE

- FROM (min. ± 0.1 kPa) _____ kPa
- TO _____ kPa

2. RESOLUTION

- 10 bits 12 bits 14 bits
- 11 bits 13 bits 15 bits

3. SUPPLY VOLTAGE

- 5 V 3.3 V

4. INTERFACE

- I²C SPI Analog Voltage

5. LOW NOISE FILTER

- No Yes

6. ALARM

- Disable Enable

If Alarm enabled, specify the pressure value: _____

7. NOZZLE VARIANT

- Vertical Straight Horizontal Barbed

Note: ±1 mbar is the smallest possible pressure range. Both the Digital I²C and SPI interfaces are not available simultaneously.

We use our proven programming and testing processes to ensure → **high quality** and → **reliability**.



Contact your local sales or email to:
wcs@we-online.com

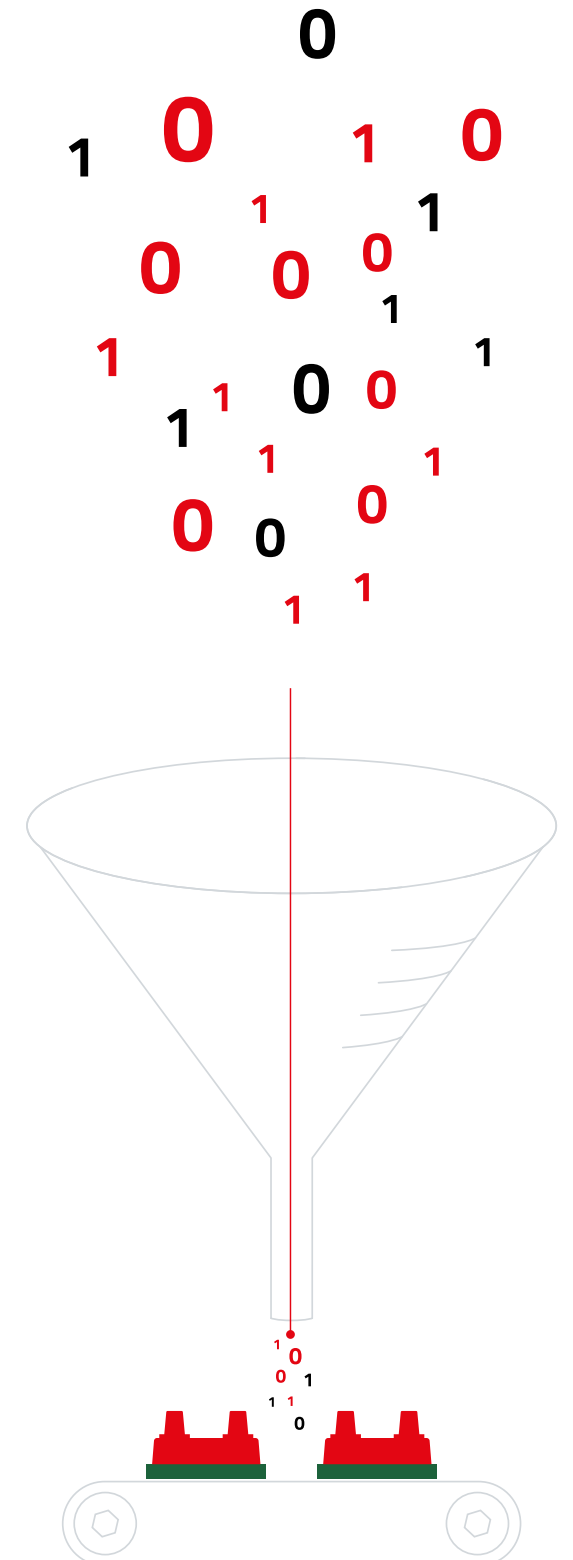

CURRENT SENSORS



FUNDAMENTALS

Sensors	Size	Price	Bandwidth	DC Measuring	Sensitivity	Dynamic Range
Current Transformer	Large	☹️	kHz - MHz	✘	1 V.A ⁻¹	A - kA
Rogowski coil	Small	😊	kHz - MHz	✘	10 mV.A ⁻¹	A - MA
Shunt resistor	Small	😊	kHz - MHz	✔	1 mV.A ⁻¹	mA - kA
FOCS Fiber-optic current sensor	Small	☹️	kHz - MHz	✔	High	kA - MA
Fluxgate current sensors	Large	☹️	kHz	✔	High	mA - kA
Hall sensors	Small	😊	kHz - MHz	✔	~250 mV.A ⁻¹	mA - kA
xMR	Small	😊	kHz - MHz	✔	~400mV.A ⁻¹	mA - kA

Measuring principles current sensors

Current Transformers (CTs) operate on the principle of inductive coupling, where the primary current induces a magnetic field in the core, which in turn induces a current in the secondary winding proportional to the primary current. Due to their design and construction, CTs are typically bulky in size. They are primarily designed for measuring alternating current (AC) and are not suitable for direct current (DC) measurements. Despite their limitations, CTs find widespread applications in electrical power systems for various purposes such as current monitoring, protection, and metering. They are commonly used in power distribution networks, electrical substations, industrial facilities, and renewable energy systems.

Rogowski is also used to measure AC current with principle of inductive coil without a magnetic Core. It measure the rate of change of current. Rogowski coils are flexible and can be easily wrapped around irregularly shaped conductors, making them suitable for a wide range of applications where CTs may not fit or require complex installation. They can also measure only AC.

Shunt resistors are typically resistors placed in series with the circuit through which the current is to be measured. When current flows through the circuit, a voltage drop occurs across the shunt resistor proportional to the current passing through it. In high-current applications, it can lead to significant power dissipation and heat generation, requiring additional cooling measures or derating of the resistor's power rating. They are typically used in Battery Management Systems, Power supplies and converters, motor control and devices.

FOCS (Fiber-optic current sensor) are based on the Faraday effect, where the polarization of light changes when it passes through a medium subjected to a magnetic field, which is proportional to the current flowing through a conductor. more expensive due to the use of fiber optics and associated electronics used in electric power systems, high-voltage environments, and areas requiring isolation. Also, high frequency response capabilities, making them suitable for various high-frequency current measurement applications.

45

48

MEASURING PRINCIPLES FLUX GATE SENSORS

WE-RCDS

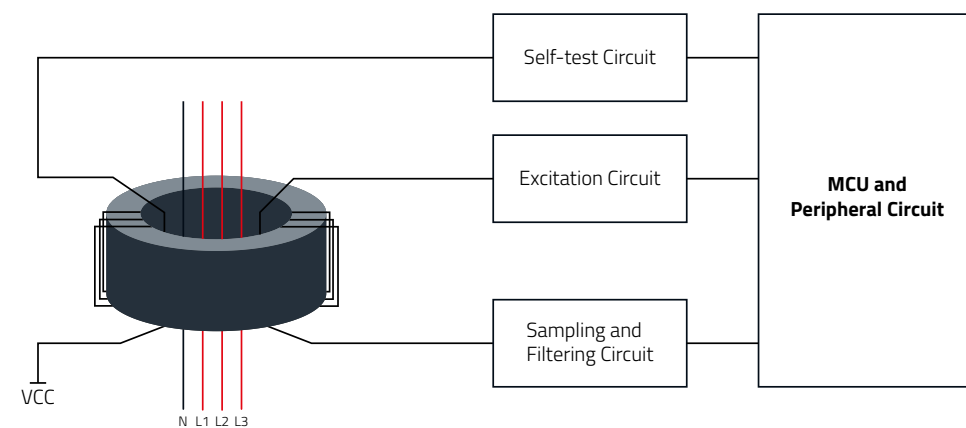

Open loop

The excitation coil drives the core into saturation and de-saturates it again. This also happens in the negative direction, so that the typical hysteresis of the soft magnetic core is operated. Without an external magnetic field, the induced voltage at the sampling resistor is symmetrical. The symmetry is interrupted by a fault current and the resulting external magnetic field. This can now be demodulated via a filter so that the fault current is detected. Current can be demodulated by hardware filter or digital filter.

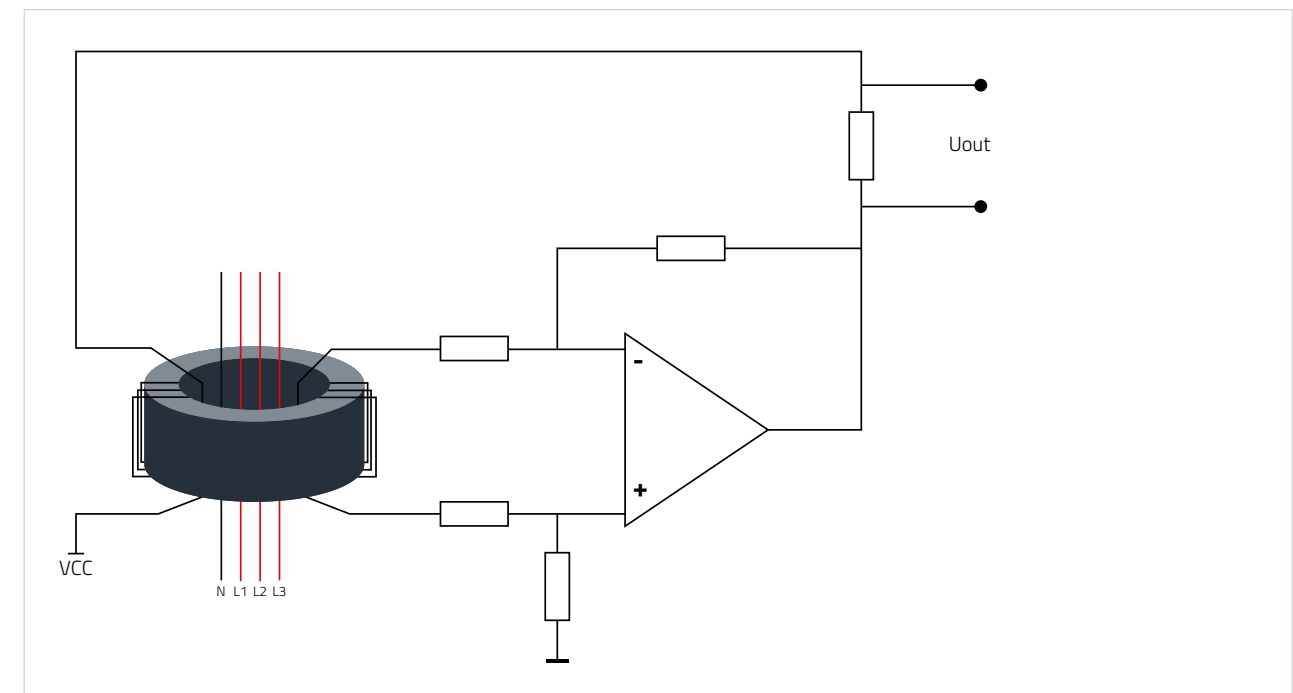

Closed loop

A compensation winding is used which counteracts the magnetic field of the fault current in the reverse direction. The aim is to ensure that the magnetic field of the fault current is fully compensated. The fault current can be calculated by using the current required for compensation.

xMR (Magnetic Resistance) current sensors operate based on the principle of magnetoresistance, specifically utilizing the anisotropic magnetoresistance (AMR) effect or the giant magnetoresistance (GMR) effect. These effects describe the change in the electrical resistance of a material in response to an applied magnetic field. In xMR current sensors, a magnetic material with variable resistance is placed in the magnetic field generated by the current-carrying conductor. As the magnetic field changes due to the current flowing through the conductor, the resistance of the material also changes proportionally. This change in resistance is measured and calibrated to determine the magnitude of the current.

In renewable energy systems such as solar inverters and wind turbines, xMR current sensors are used for current monitoring in power conversion and energy storage systems. They assist in optimizing energy harvesting, ensuring efficient operation, and maintaining system reliability.

xMR current sensors are used in automotive systems for current monitoring in battery management systems, motor control units, and safety systems.

Hall effect sensor measure the magnetic field generated by the current flow in a conductor. As the current flows through the conductor, it creates a magnetic field perpendicular to both the current and the Hall element. The Lorentz force causes the charge carriers in the semiconductor material to be deflected, resulting in the accumulation of charge on one side of the Hall element and an equal and opposite charge accumulation on the other side, generating a voltage difference proportional to the applied magnetic field and, consequently, the current being measured. This Hall voltage is then measured and calibrated to determine the magnitude of the current flowing through the conductor.

Hall-based current sensors find widespread applications in various industries, including automotive, industrial automation, power distribution, and consumer electronics. They are used for current monitoring, overcurrent protection, motor control, and energy management applications, offering advantages such as galvanic isolation, high accuracy, and wide dynamic range, making them indispensable in modern electrical systems.

WE-RCDS

Flux gate sensors measures the changes in magnetic flux density induced by the current-carrying conductor. It consists of a core made of magnetically permeable material and excitation coils. The core's magnetic properties change with the applied current, allowing for current measurement. Fluxgate sensors are highly sensitive to changes in magnetic fields, making them suitable for detecting weak magnetic fields with high accuracy.

In industrial automation, fluxgate current sensors are used for current monitoring in motor control systems, process control equipment, and machinery. They provide accurate feedback for controlling motor speed, torque, and power consumption in manufacturing, robotics, and material handling applications.

Fluxgate current sensors are employed in power electronics for monitoring and controlling currents in converters, inverters, motor drives, and power distribution systems.

PRODUCTS



WE-RCDS

For fault current detection in EV-charging applications



Product Features



- Compact design for PCB board mounting
- 3-phase primary conductors on module
- DC 6mA residual direct current detecting RDC-M-Module for mode 3 EV charging
- Digital open-drain output, 6mA DC trip indication
- PWM output for DC residual current value indication (only part 791002004)
- Supply voltage drop monitoring
- Error or PWM output for system fault indication
- Designed to meet standard: IEC 62955: 2018
- Module Software certified according to ANSI/UL 1998, Class 1
- Partially EMC tested according to IEC 62955: 2018 and EN 60730-1, report on Request

Order Code	Version	Typ	I_{dn}	I_p	Operating Temperature
791002002	Horizontal	3-phase primary conductor	6 mA DC	40 A max.	-40 °C up to +105 °C
791002004	Vertical	Cable Through Hole	6 mA DC	80 / 40 A max.	-40 °C up to +105 °C

I_{dn} : Rated Residual Operating Current; I_p : Primary Current

Supply Voltage Monitoring Diagram

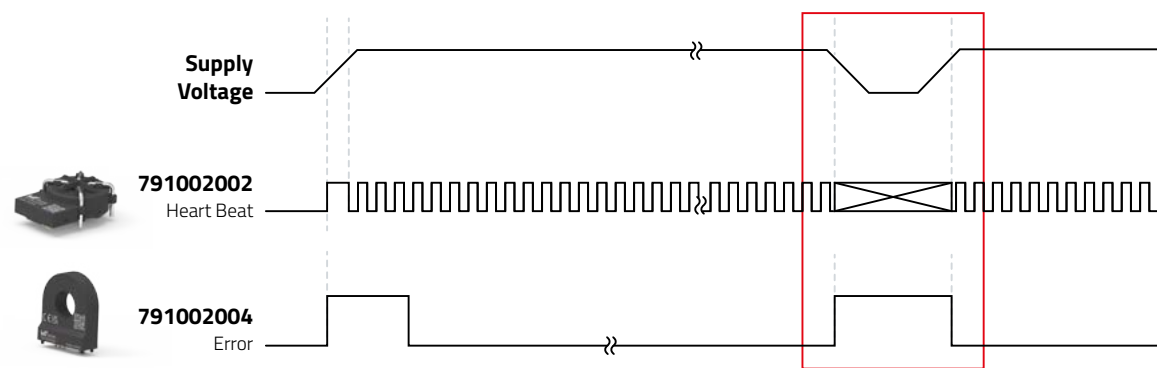

To ensure accurate fault current detection, the sensor supply voltage should be monitored by using the PWM signal (791002002) or the Error output (791002004).

Current Measuring in charging infrastructure - overview

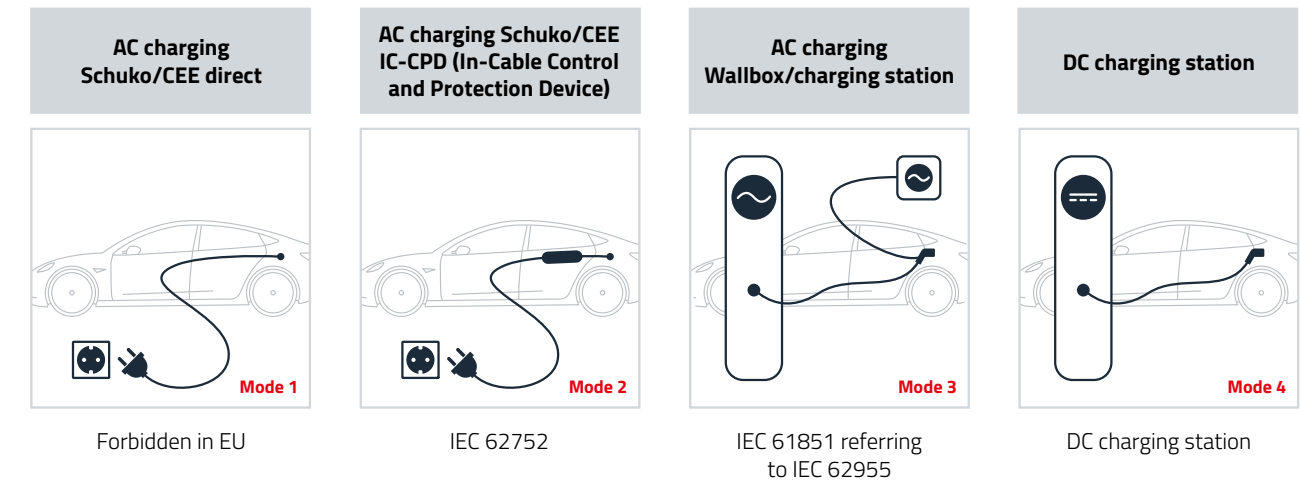

Functional diagram

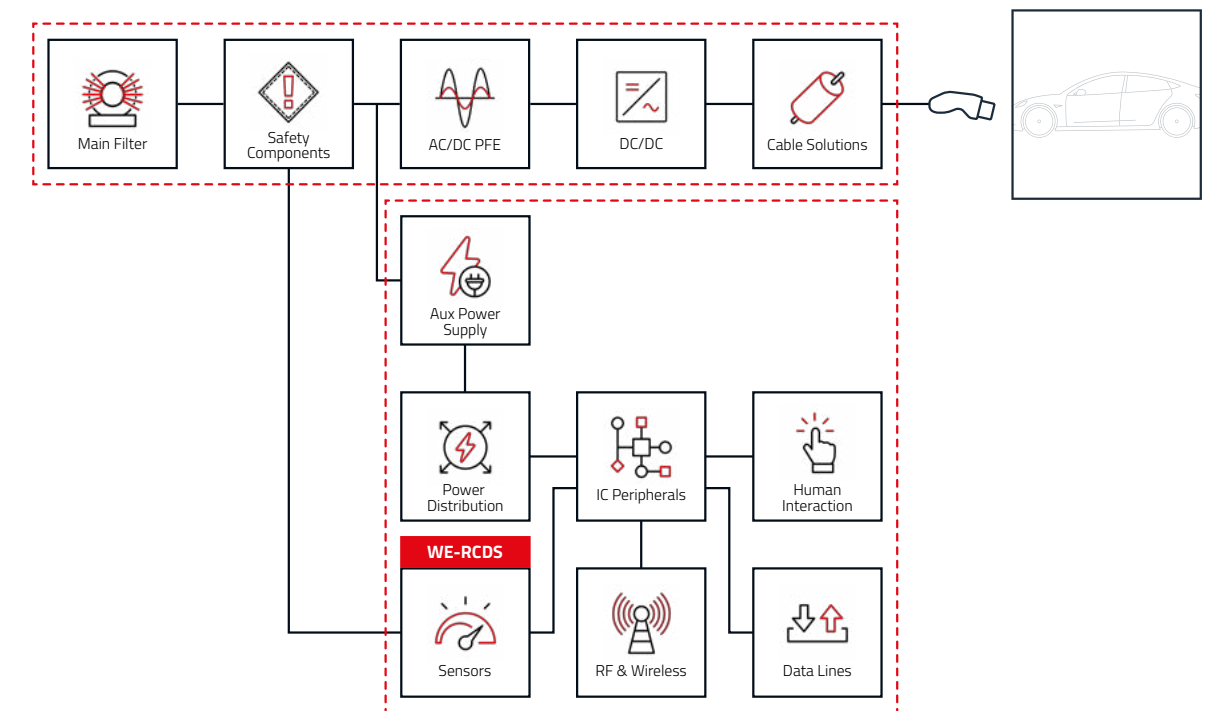

Residual Trip Current

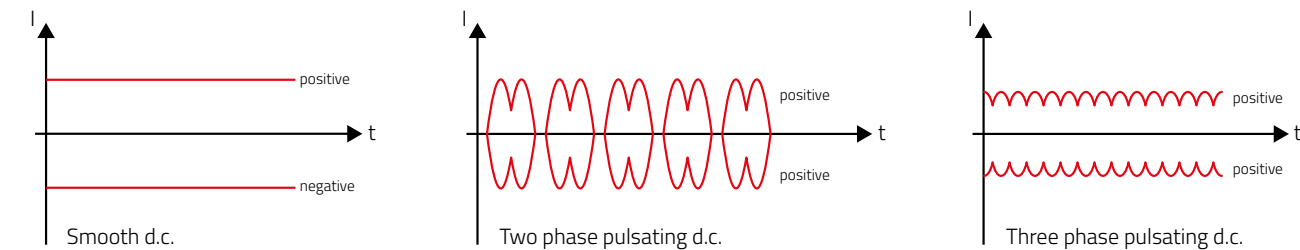

SENSOR SOFTWARE DEVELOPMENT KIT

Communication with the sensors is done by reading from and writing to registers via I²C and/or SPI interfaces. The manuals and app notes describe the usage of the sensors on register level. The Sensors SDK is an abstraction layer that provides functions and data types which handle the low-level communication with the sensor at register level for you. This allows easy access to the functions behind the registers.

The SDK is Open source, written in C, ready-to-use in customer software and can also be modified by customers as required by their application.



Features

- Conversion of sensor readings (raw data to user units) for different sensor configurations.
- Communication layer (I²C, SPI) – pre-configured and ready-to-use for each type of sensor.
- Configuration and control of e.g.
 - Data rates
 - Operating modes
 - Interrupts
 - Buffering and batch transfer of sensor readings (FIFO)
 - Embedded functions (e.g. free-fall detection for acceleration sensor or detection of high/low pressure events for absolute pressure sensor)

Extensive examples for both basic and advanced usage – providing an overview of the sensor's functionality, low-threshold way of getting acquainted with the sensors (-> prototyping)

Basic usage

E.g. operating modes, data rates, interpreting raw data, one shot sensor read

Advanced usage

E.g. Embedded functions, interrupts, buffering of data (FIFO)

"Plug-and-play" support

"Plug-and-play" support of currently two STM32 microcontrollers (STM32G031, STM32L432) – SDK structure allows adaption to other STM controllers and porting to other MCUs by replacing platform-specific functions (basically functions performing low-level communication via I²C or SPI and setting up Clocks, Timers, GPIOs and Interrupts).

A **graphic** showing two simplified use-cases, such as reading single values triggered by the host or reading a batch of buffered values triggered by a sensor event (such as wake-up, free-fall etc.).

The left hand flow of the graphic matches the code comparison below.

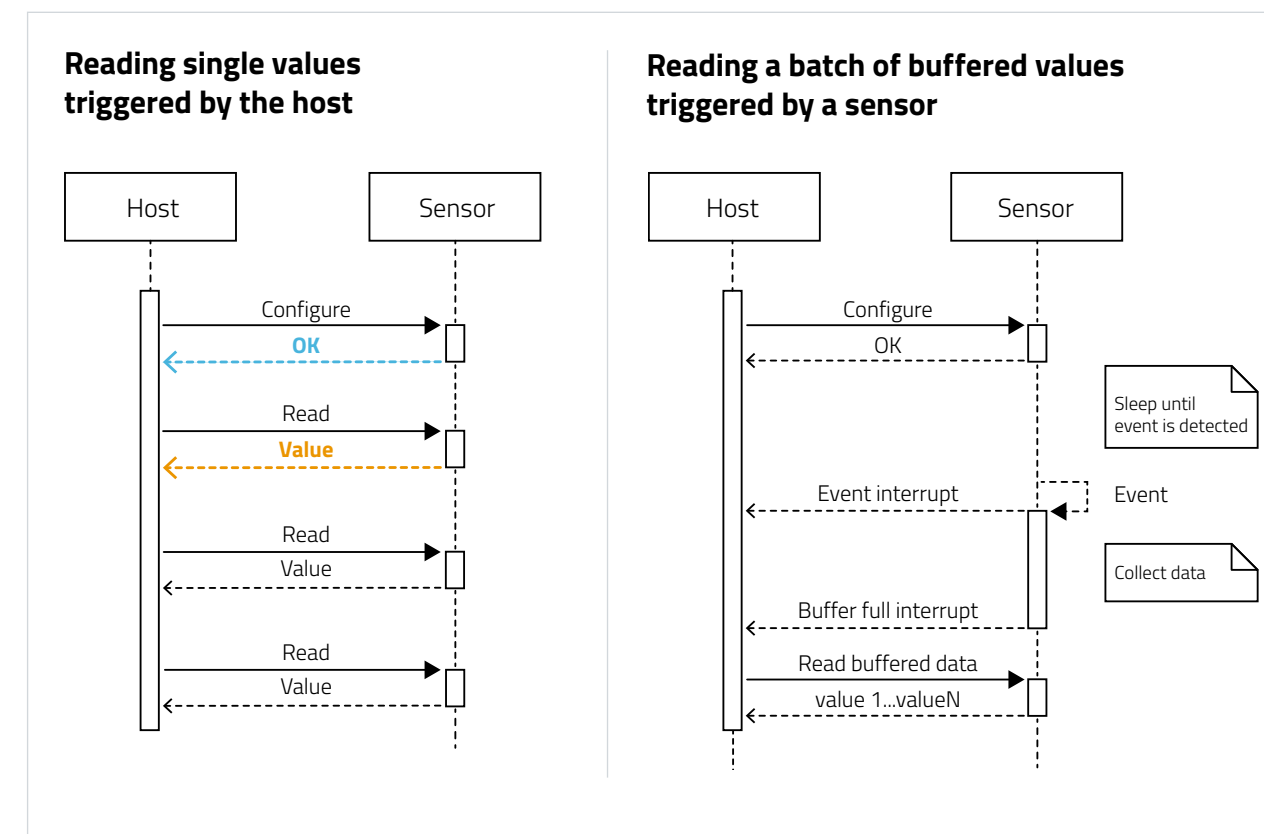

Code Comparison „Reading single values“ – With and without SDK

WITHOUT SDK

Short but not readable

Init:

1. Write value 0x64 into register 0x20
2. Write value 0x0C into register 0x21
3. Write value 0x04 into register 0x25
4. Wait until bit 0 of register 0x27 is '1'
5. Read registers 0x28 to 0x2D, combine pairs into 16 bit values for x,y and z
6. Multiply with "acceleration sensitivity" value to convert raw values to user units

WITH SDK

Longer but readable

Init:

1. SetOutputDataRate(200Hz)
2. EnableHighPerformanceMode(true)
3. EnableBlockDataUpdate(true)
4. EnableAutoIncrement(true)
5. EnableLowNoise(true)
6. SetFullScale(2g)
7. Wait until IsAccelerationDataReady() returns true
8. getAccelerationsData(x,y,z)

ADDED VALUES

Development Tools

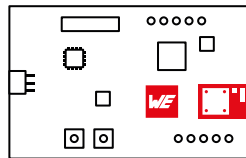

Eval Boards

- Easy testing
- No problem with hand soldering of small sensors
- I²C directly accessible



we-online.com/EVAL-SENS



More information on page 16



FeatherWing

- Adafruit standard
- Easy connectable
- For complex system tests



More information on page 16

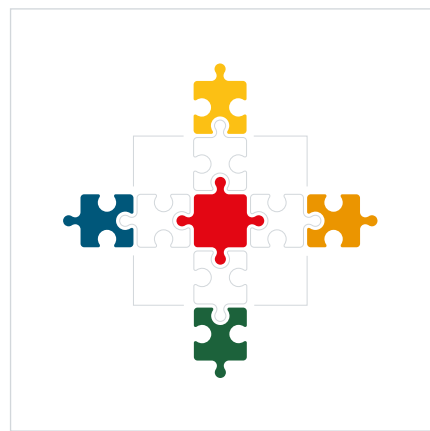

Software Development Kit

- Typically as C-Files, for mobile Apps platform specific languages
- For comfortable coding of:
 - The HOST-controller communication with the module via UART
 - PC Applications & Mobile Apps
- Code examples in Application notes and Manuals



we-online.com/WSEN-SDK

AppNotes



AppNote: MEMS Sensor PCB Design and Soldering Guidelines

we-online.com/ANM001



Human Fall Detection with 3-Axis MEMS Acceleration Sensor

we-online.com/ANM002



Pressure Altimeter using Absolute Pressure Sensor WSEN-PADS

we-online.com/ANM003

MORE ADDED VALUES



Long Term Availability



Technical Support – Talk from Engineer to Engineer

Custom Sensor Characterization

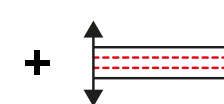
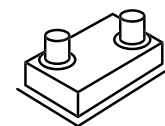

001101
010100
101101

1. PRESSURE RANGE
2. RESOLUTION
3. SUPPLY VOLTAGE
4. INTERFACE
5. NOZZLE VARIANT



Evaluation Kits and FeatherWings for easy and rapid prototyping

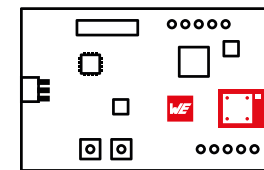

Eval Boards

- Easy testing
- No problem with hand soldering of small sensors
- I²C and/or SPI directly accessible

FeatherWing

- Adafruit standard
- Easy connectable
- For complex system tests



APIs and Software Development Kits

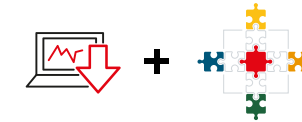

SDK & Github Repositories:
github.com/WurthElektronik/



Zephyr Sensor Driver:
we-online.com/ANR034

MEMS Sensor Portfolio & Customer Service

Sensors are an integral part of every future application. Measuring temperature, humidity, pressure or acceleration has never been easier. Take advantage of services like our Software Development Kit and Evaluation Boards available off-the-shelf. Detailed documentations as well as the direct support by trained engineers will leave no questions open. With excellent measuring accuracy and long-term stability, the sensors provide high precision and accurate output values with intelligent on-chip interrupt functions.

- Support by engineers within 24 h
- Cut&Tape: No MOQ and small packing units
- Long term availability
- Small size
- Low power consumption
- Excellent measuring accuracy
- Factory calibrated & ready to use
- SPI & I²C digital interfaces

Combine sensors and wireless connectivity – start your IoT application today: www.we-online.com/sensors

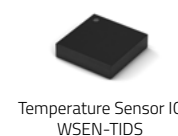

Temperature Sensor IC
WSEN-TIDS



Humidity
WSEN-HIDS



3 Axis Acceleration
WSEN-ITDS



6 Axis Acceleration
WSEN-ISDS



Absolute Pressure
WSEN-PADS



Differential Pressure
WSEN-PDUS

DISCOVER THE WORLD OF WIRELESS CONNECTIVITY



56

74

58

78

64

80

68

84

70

HOW TO GET STARTED WITH WIRELESS CONNECTIVITY



WIRELESS GUIDE







How to find the suiting product?

This Wireless Guide will help you to find a solution for your application! Answer the following questions, as far as you can and with the information in the last pages, you will be able to take a decision.

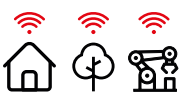

If there is any need of support: Contact us!

wcs@we-online.com

1. Region	2. Range	3. Environment	4. Data	5. Energy	6. Interface
					
In which region will the application run or should be used in the future?	What range do you need to cover in your application?	In which environment will your application be used?	How much data has to be transmitted? Which data rate is required?	What about power consumption? How much energy is available? How long should a battery last?	Communication to...?
<input type="checkbox"/> Europe <input type="checkbox"/> North America <input type="checkbox"/> South America <input type="checkbox"/> Asia <input type="checkbox"/> worldwide <input type="checkbox"/> other: _____	<input type="checkbox"/> 0 - 15 m <input type="checkbox"/> 15 - 50 m <input type="checkbox"/> 50 - 100 m <input type="checkbox"/> 100 - 500 m <input type="checkbox"/> 500 m - 2 km <input type="checkbox"/> 2 km - 10 km <input type="checkbox"/> >10 km	<input type="checkbox"/> Indoor <input type="checkbox"/> Outdoor <input type="checkbox"/> Industrial <input type="checkbox"/> Home Automation <input type="checkbox"/> other: _____	<input type="checkbox"/> Very low data rate (up to 1 kbps) <input type="checkbox"/> Middle data rate (up to 100 kbps) <input type="checkbox"/> High data rate (>100 kbps) <input type="checkbox"/> Very high data rate (>500 kbps)	<input type="checkbox"/> Long term battery powered <input type="checkbox"/> Battery powered <input type="checkbox"/> Main powered <input type="checkbox"/> other: _____	<input type="checkbox"/> Smart Device (Mobile, Tablet) <input type="checkbox"/> PC, Server, etc. <input type="checkbox"/> Device of own development <input type="checkbox"/> Special communication interface (Wirepas, wM-Bus, CAN-Bus, ...) <input type="checkbox"/> Mesh (Wirepas, Bluetooth® Mesh, Closed Mesh) <input type="checkbox"/> other: _____

RADIO TECHNOLOGIES OVERVIEW

	LICENCE FREE ISM BANDS (INDUSTRIAL SCIENTIFIC MEDICAL)							LICENCED CELLULAR BANDS					
	169	433	868	915	1500	2400	5000	700	900	1800	2100	2600	3500
Frequency [MHz]	169	433	868	915	1500	2400	5000	700	900	1800	2100	2600	3500
Wavelength [cm]	178	69	35	33	20	13	6	43	33	17	14	12	9
Radio Protocol	M-Bus WIRELESS M-BUS WIRELESS M-BUS	M-Bus WIRELESS M-BUS WIRELESS M-BUS	M-Bus WIRELESS M-BUS WIRELESS M-BUS Long-Range sigfox zigbee Z-WAVE enocean mioty	M-Bus WIRELESS M-BUS WIRELESS M-BUS Long-Range sigfox zigbee Z-WAVE enocean	Bluetooth WIFI zigbee matter THREAD Wirepas IEEE 802.15.4 ANT+	Bluetooth WIFI zigbee matter THREAD Wirepas IEEE 802.15.4 ANT+	Bluetooth WIFI zigbee matter THREAD Wirepas IEEE 802.15.4 ANT+	lte 5G	NB-IoT LTE-M GSM	UMTS			
Range	middle	middle	high	high	high	low	low	high	high				
Data Rate	low	low	middle	middle	low	high	high	high	low				
Würth Elektronik Antennas													
Typical Certification	CE	CE	CE	FCC, IC	worldwide	worldwide	worldwide	worldwide	worldwide				

RADIO PROTOCOL		
 <ul style="list-style-type: none"> Proprietary (non-standard) radio protocol Great flexibility and adaptability Communication closed to the outside, security factor 	 <ul style="list-style-type: none"> Decentralized, intelligent routed mesh protocol High scalability even with a very large number of network nodes possible 	 <ul style="list-style-type: none"> Standardized interface for energy counters (electricity/gas/water/heat) According to EN13757-4, OMS SmartMeterGateway as defined remote station
 <ul style="list-style-type: none"> Bluetooth® classic, Basic Rate (BR), Enhanced Data Rate (EDR), High Speed (HS) Standardized connection to smart devices High data rates possible Esp. audio connections 	 <ul style="list-style-type: none"> Bluetooth® Low Energy Standardized, simple connection to smart devices Low energy requirements Low data rates, typically for parameterization, service interfaces, remote displays, etc. 	 <ul style="list-style-type: none"> Idea of also being able to integrate smart devices into mesh networks Based on Bluetooth® LE, but is not directly and automatically compatible/combinable Higher energy consumption than Bluetooth® LE due to continuous readiness to receive
 <ul style="list-style-type: none"> Actually Wireless Local Area Network (WLAN) WiFi is a marketing name Standard of IEEE-802.11 High data rates possible Worldwide standardized in use 	 <ul style="list-style-type: none"> Global Navigation Satellite System (GNSS) Positioning and Navigation Generic term for GPS (US), GLONASS (RUS), GALILEO (EU), BEIDOU (C) and others 	 <ul style="list-style-type: none"> Managed by LoRa® Alliance® Long-Range-WAN widely deployed LPWAN (Low Power Wide Area Network) Low power consumption and high range Open networks can be shared if available

RADIO PROTOCOL			
 <ul style="list-style-type: none"> Own global radio network Low data rates, high ranges 	 <ul style="list-style-type: none"> Developed by Sigma Designs and the Z-Wave Alliance Low power consumption 	 <ul style="list-style-type: none"> LPWAN Application High range, low data rate, Low power consumption Managed by MIOTY Alliance Licensed by Fraunhofer 	
 <ul style="list-style-type: none"> Low energy consumption and low data volume ZigBee Alliance consists of over 200 companies 	 <ul style="list-style-type: none"> IPv6-based mesh networking technology Thread Group working group continues to develop Open Thread released by Google Nest 	 <ul style="list-style-type: none"> Connectivity Standards Alliance (CSA) with more than 250 members, including Apple, Google, Amazon, IKEA, and many others Smart home standard (scheduled for release in 2022) Uses Thread, WiFi and BLE as protocols 	
 <ul style="list-style-type: none"> Managed by ANT+ Alliance, belonging to Garmin Very low data rates, very Low power consumption E.g. widespread in the fitness equipment market 	 <ul style="list-style-type: none"> Transmission protocol for Wireless Personal Area Networks (WPAN) Defines only PHY and MAC layer of the OSI model 	 <ul style="list-style-type: none"> Battery free wireless sensor technology (energy harvesting) with very low energy consumption EnOcean Alliance with 400 members 	
 <ul style="list-style-type: none"> Global System for Mobile Communications (GSM) Second-generation mobile communications standard (2G) after analog systems (1G) Used in 670 GSM mobile communications networks in around 200 countries and territories in the world GPRS and EDGE are part of GSM 	 <ul style="list-style-type: none"> Universal Mobile Telecommunications System (UMTS)* Mobile communications standard of the 3rd generation (3G) HSDPA and HSPA+ are part of UMTS <p>* Will not be supported / disabled in the future</p>	 <ul style="list-style-type: none"> Long Term Evolution (LTE) 3rd generation (3G) mobile communications standard Only part of 4G with LTE-Advanced 	
 <ul style="list-style-type: none"> Narrowband-IoT (NB-IoT / also CAT-NB1/NB2) Based on LTE Low data rates, high ranges 	 <ul style="list-style-type: none"> Based on LTE High data rates possible Low energy consumption 	 <ul style="list-style-type: none"> 5th generation mobile communications standard (5G) Significantly higher frequencies used, but therefore also smaller wavelengths, which require more closely meshed networks 	
Legend WE module available USB radio stick available Customized implementation possible on request			
Mesh Tracking & Positioning Agriculture	Measurement & Automation Medical Devices Smart Device Interface	Automated Meter Reading e-Mobility Cloud Connectivity/IoT	Sensor Systems Lighting

RADIO TECHNOLOGIES

COSTS AND LEGAL BASICS

Short Range Device (SRD)

Short Range Devices (SRD) are radio devices that offer a low risk of interference with other radio services, usually because their transmitted power, and hence their range, is low., typically few hundred meters. SRD often benefit from a relaxed regulatory regime compared with other radio communication equipment. The use is license free in general. However the radio regulations have to be considered, as the Radio Equipment Directive in Europe.

Frequency [MHz]	TX Power [dBm]	TX Power [mW]	Duty cycle	max. occupied BW* [kHz]	Notes
169.400 - 169.475	+ 27	500	≤ 1 %	50	For metering devices: 10 % DC
169.400 - 169.4875	+ 10	10	≤ 0.1 %	whole band	
169.4875 - 169.5875	+ 10	10	≤ 0,001 %	whole band	0,1 % DC during 0:00 and 6:00 local time
169.5875 - 169.8125	+ 10	10	≤ 0,1 %	whole band	
433.050 - 434.790	+ 10	10	10 %	whole band	
433.050 - 434.790	0	1	no limits	whole band	-13 dBm / 10kHz PSD when bw > 250 kHz, audio/video applications are excluded
434.040 - 434.790	+ 10	10	no limits	25	audio/video applications are excluded
863.0 - 865.0	+ 14	25	≤ 0.1 % or PSA**	whole band	OBW restrictions except audio & video limited to 300 kHz
865.0 - 868.0	+ 14	25	≤ 1 % or PSA**	whole band	
868.0 - 868.6	+ 14	25	≤ 1 % or PSA**	whole band	
868.7 - 869.2	+ 14	25	≤ 0.1 % or PSA**	whole band	
869.4 - 869.65	+ 27	500	≤ 10 % or PSA**	whole band	
869.7 - 870.0	+ 7	5		whole band	audio / video applications are excluded
869.7 - 870.0	+ 14	25	≤ 1 % or PSA**	whole band	analogue audio / video are excluded
2400.0 - 2483.5	+ 10	10	no limits	whole band	non specific short range devices
2400.0 - 2483.5	+ 14	25	no limits	whole band	radio determination devices (radar, RFID,...)
2446.0 - 2454.0		500 / 4000		whole band	RFID only

* BW = Band width

** PSA = Polite Spectrum Access, allows up to 100s sending per 1 hour observation time, so a duty cycle of up to 2.77%



Both long-range and Long-Range-WAN are legally protected designations and the use of the logos is not permitted without further approval. Permission from Semtech is required for the use of the long-range logo. This can be applied for free of charge if a Semtech chipset is used. Long-Range-WAN is protected by the LoRa Alliance®. Use of this logo requires membership. Membership levels (yearly costs): Institutional(\$0), Adopter (Start-Up) (\$3k), Adopter(\$6k), Contributor(\$20k), Sponsor (\$50k). Source: www.semtech.com/lor; www.lora-alliance.org.

Long-Range-WAN International useable frequencies

Country/Region	Frequency
EU	863 – 870 MHz (EU868), 433 – 434 MHz (EU433)
USA	902 – 928 MHz (US915)
China	470 – 510 MHz (CN470), 779 – 787 MHz (CN779)
Australia	915 – 928 MHz (AU915)
Asia/Japan	923 MHz (AS923), 920 – 923 MHz (KR920)
India	865 – 867 MHz (IN865)

Modes and frequencies Wireless M-Bus

Mode	Uplink Parameters	Downlink Parameters
S	868.3 MHz, 16.384 kbit/s, Manchester	868.3 MHz, 16.384 kbit/s, Manchester
T	868.95 MHz, 66.667 kbit/s, 3-out-of-6	868.3 MHz, 16.384 kbit/s, Manchester
C	868.95 MHz, 100 kbit/s, NRZ	869.525 MHz, 50 kbit/s, NRZ

Comparison Bluetooth® Mesh – Proprietary Mesh – Wirepas Mesh

	Nodes	Latency	Throughput	Power	Costs
Bluetooth® Mesh	😊	😞	😞	😊	😊
Wirepas Massive	😊	😞	😊	😊	😊
WE Proprietary Mesh	😊	😊	😊	😞	😊
Zigbee	😊	😊	😊	😊	😊
Thread	😊	😊	😊	😊	😞

WiFi Certification

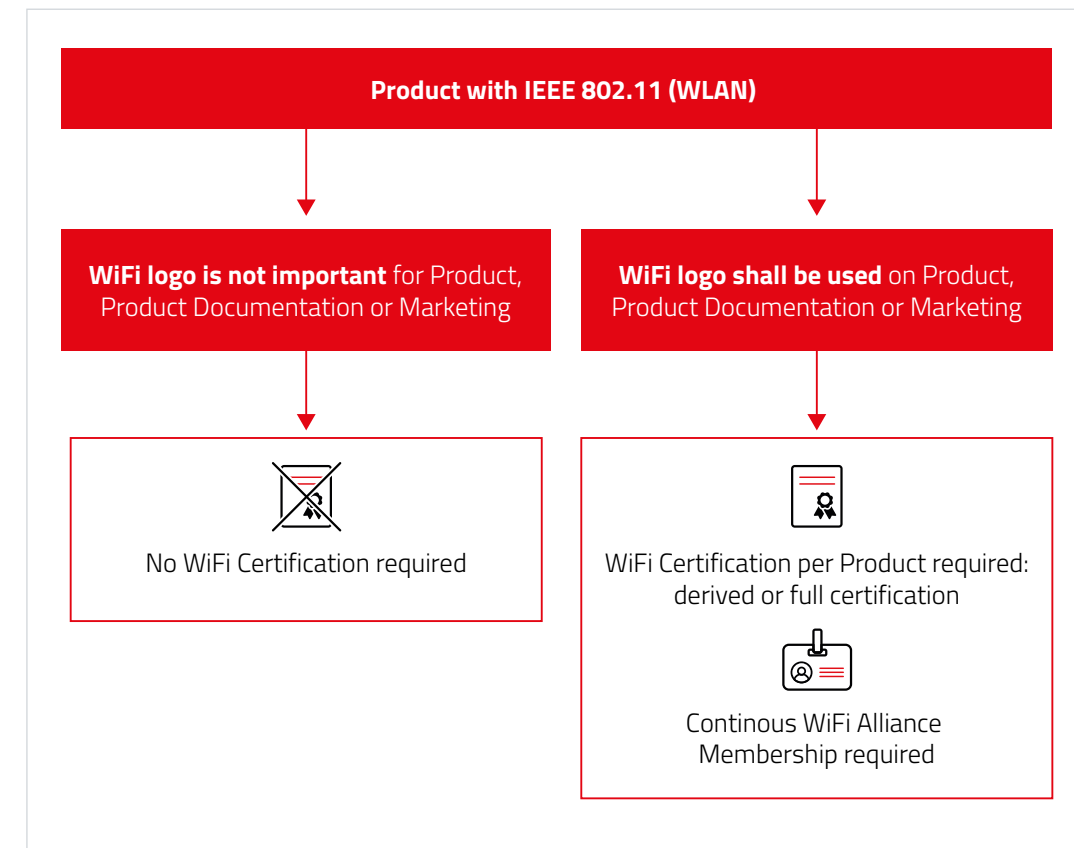

BLUETOOTH® SPECIAL INTEREST GROUP (SIG)

Different Memberships

Promoter Members

Have considerable influence over both, the strategic and technological directions of Bluetooth® (Apple, Intel, IBM,...).

Associate Members

Get early access to draft specifications and are eligible to participate and gain a voting seat in working groups and committees. Furthermore, to work with other Associate and Promoter members on enhancing existing specifications.

Adopter Members

Use published Bluetooth® wireless specifications and Bluetooth trademarks.

Listing - Qualification and Declaration

- The Bluetooth® listing consists of qualification and declaration
- The qualification process is one of the most important aspects of **Bluetooth® technology, supporting interoperability** and conformity to the Bluetooth® specifications
- Bluetooth® Qualification Consultants (BQCs) are available to support members through the processes
- Qualification means the whole process including tests
- Members of the Bluetooth® SIG must complete the qualification and declaration process for their Bluetooth® enabled product to demonstrate and declare compliance
- The distributor is responsible to ensure that the required listing is performed
- A Listing is possible, if an already qualified product is used. Then there is no measuring or testing effort, only declaration and information work to be done
- BT Listing USD 11,040 per end device

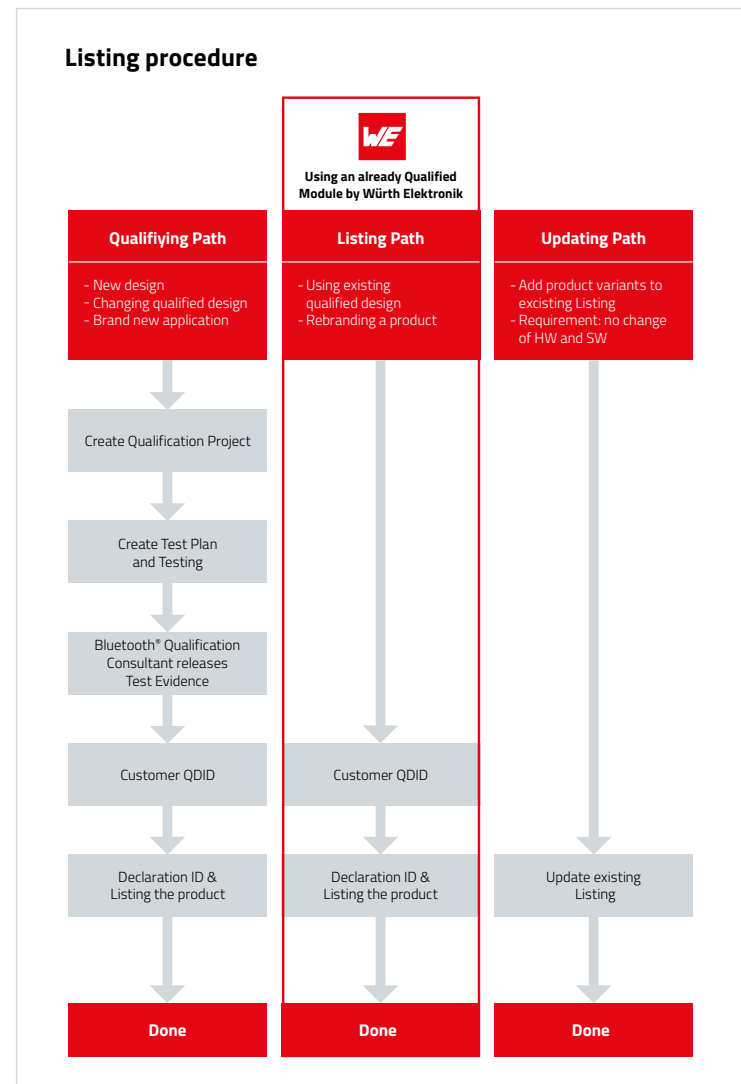

Reasons for Bluetooth® in Industry

- ✓ Smart and innovative
- ✓ Robust and open communication
- ✓ Use smart device as display
- ✓ Worldwide common standard

CERTIFICATION CELLULAR

WE + Normal Cellular Certification Procedure

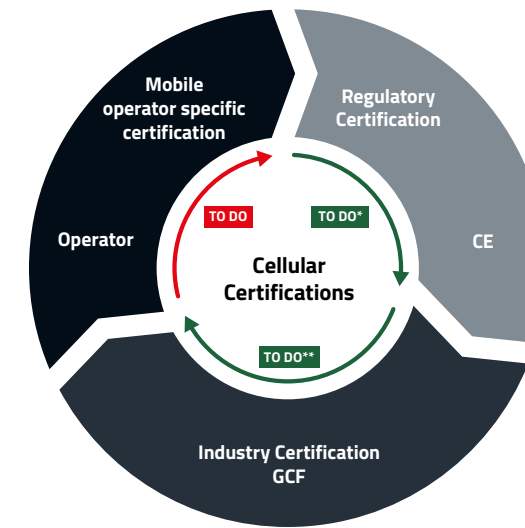

* To do on device level, Adrastea-I offers CE declaration
** To do on device level, Adrastea-I offers GCF certification

WE + T-Mobile Certification

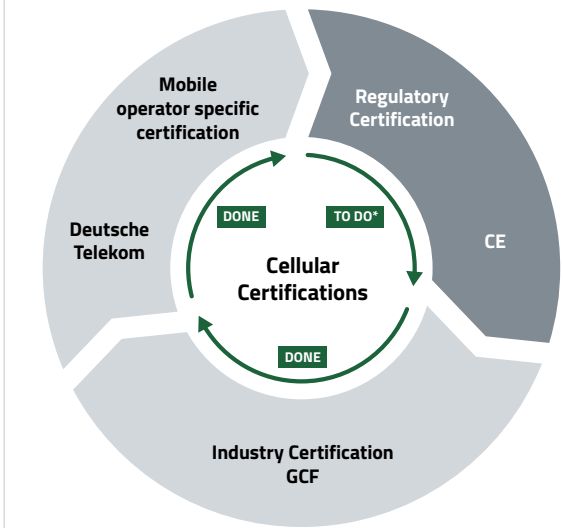

Regulatory Certification: Country specific to comply with country's regulations. Testing covers safety aspects, RF emissions do not interfere with other wireless equipment's (e.g. RF transmitter and receiver tests, EMC, electrical safety and environmental).

Industry Certification: The Global Certification Forum (GCF) is a certification organization in which manufacturers, operators and test laboratories deal with the compliance of devices in mobile networks with 3GPP standards and specifications.

Mobile operator specific certification: Testing specific to their network configuration and network parameter settings. This testing is focusing on field performance of the devices, such as radio sensitivity, data throughput.

Normal Cellular Certification Procedure



End Product with Cellular Module

2 Types of Certification are mandatory for End Product:

1. Regulatory Certification: CE
2. Network Operator Certification: Vodafone, Deutsche Telekom etc.

WE - Deutsche Telekom Certification



End Product with WE-DTAG Certified Module

Certification is mandatory for End Product:

1. Regulatory Certification: CE



Benefits of WE - Deutsche Telekom Certified Module

Be smart and ensure that your product does not require certification again.

Optain assurance – Pre-certified module reduces final test effort.

Save time and money – the end product does not require to go through complex cellular certification process again

FUNDAMENTALS

RADIO COMMUNICATION

The History of Radio Technology

Radio technology is a wireless method of transmitting signals by means of modulated electromagnetic waves. In 1884 James Clerk Maxwell predicted the existence of radio waves, which was experimentally confirmed by Heinrich Hertz on November 11th, 1886.

There are five main key facts, which have to be considered:

1. Transmission of the signal
2. Link budget
3. Duty cycle
4. Access
5. Integration of radio technology

1. Transmission of the Signal

For the transmission, the signal will be modulated on a carrier signal, mostly sinus with constant amplitude. Thereby, the amplitude or frequency will be adopted in the rhythm of the transmitted signal. The modulated wave is radiated by an antenna and received on the other side with an antenna too. Due to demodulation at the receiver, the transmitted signal can be used.

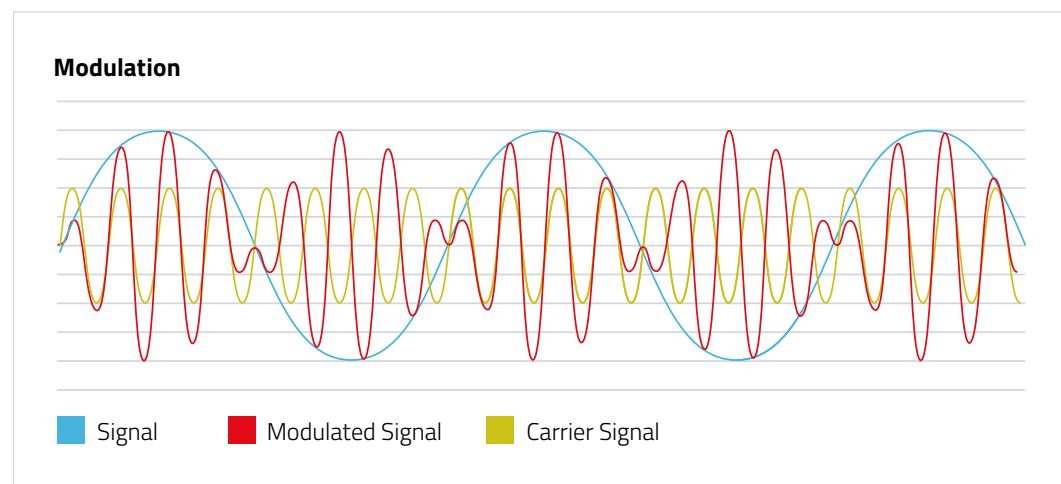
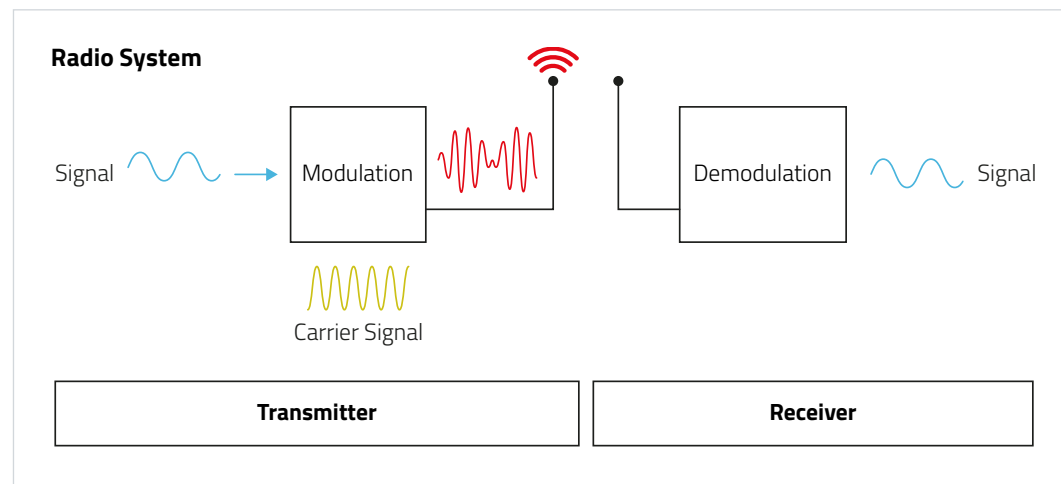

Range Estimation

When a radio connection is planned, the given circumstances define largely the requirements for radio range, operating temperature and available space.



ANR010 Range Estimation

we-online.com/ANR010

Model 1: Friis Transmission for Free Space

Friis transmission for free space is a model to calculate the path loss, to estimate the range of a radio link in a free space environment. Free field condition: The first Fresnel zone is free of objects.

This model makes the assumption, that the emitted power is radiated equally in every direction (isotropic) and calculates the power loss only taking into account the decreasing power density of the wavefront with increasing distance to the origin, without any reflection, absorption or attenuation.



It should be known, that the lower the frequency is, the bigger is the physical dimension of the antenna.



Model 2: Two-ray Ground Reflection

The two-ray ground reflection model is applied, when transmitter and receiver are in line of sight but the first Fresnel zone is not free of objects. So the calculation considers the received power of the direct line of sight path and in addition the power of the reflection path with slight phase difference.

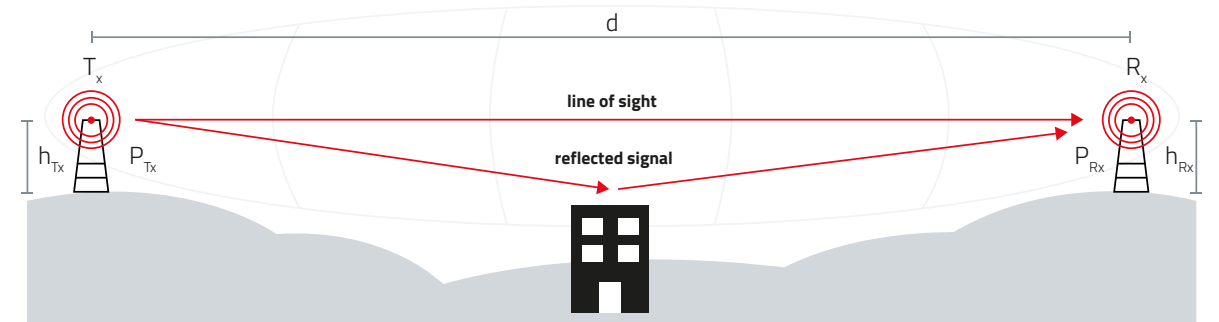

As long as the free space requirements are not met, it should be known, that the higher the antenna is mounted above ground, the higher is the possible range of the transmission path.

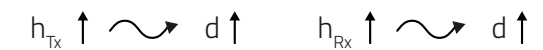

FUNDAMENTALS

RADIO COMMUNICATION

Conclusion

In a lot of cases there is the need of long distances with regards to the antenna height, so usually the two ray ground model is a good fitting estimation. Only for some special cases with the free space condition fulfilled, the Friis model is applicable. Having a closer look to the models, there are several interesting points to mention.

The Dependency of the Frequency

Often it is mentioned in general, that the lower the frequency is, the greater the range is. We have learned, that this is only the case when free field conditions are met. But there are other effects of the frequency, as the fact, that for higher frequencies, smaller objects will cause reflections or that for low frequencies it might be hard to find an antenna with acceptable size and efficiency.

The Influence of the Antenna Height on the Range

The higher the antennas can be placed, the longer is the range that can be reached. Placing an antenna directly above ground, reduces the range so radical, a layman could hardly imagine.

2. Link Budget (power of the carrier)

A link budget is an accounting of all of the power gains and losses that a communication signal experiences in a telecommunication system; from a transmitter, through a medium (free space, cable, waveguide, fiber, etc.) to the receiver. It is an equation giving the received power from the transmitter power, after the attenuation of the transmitted signal due to propagation, as well as the antenna gains and feedline and other losses and amplifications of the signal in the receiver or any repeaters it passes through.

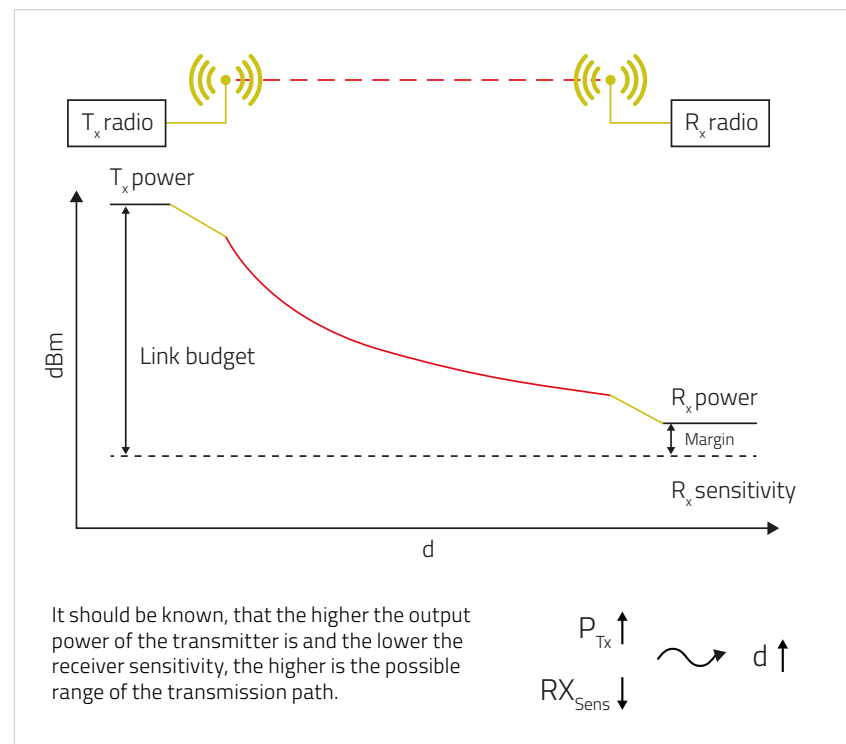

Power [dBm]	Power [watt]
- 120 dBm	1 fW
- 110 dBm	0.01 pW
- 100 dBm	0.1 pW
- 90 dBm	1 pW
- 80 dBm	10 pW
- 70 dBm	100 pW
- 60 dBm	1 nW
- 50 dBm	10 nW
- 40 dBm	100 nW
- 30 dBm	1 μW
- 20 dBm	10 μW
- 10 dBm	100 μW
- 1 dBm	794 μW
0 dBm	1 mW
1 dBm	1.26 mW
10 dBm	10 mW
20 dBm	100 mW
30 dBm	1 W
40 dBm	10 W

3. Duty Cycle

A duty cycle or power cycle is the fraction of one period in which a signal or system is active. Duty cycle is commonly expressed as a percentage or a ratio. A period is the time it takes for a signal to complete an on-and-off cycle. E.g. using a duty cycle of 10 %, means that the used transmitter is allowed to send 6 minutes within one hour.

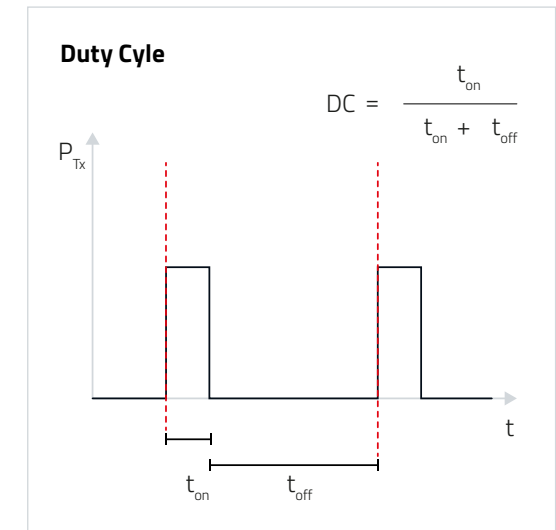

4. Polite Spectrum Access – listen before talk

When an application uses polite spectrum access, the duty cycle restrictions are loosened. Polite spectrum access encompasses two aspects: Listen Before Talk (LBT) and Adaptive Frequency Agility (AFA). LBT defines that the device must listen if the medium is already in use by a Clear Channel Assessment (CCA) check. When the medium is in use, the device must wait a random backoff interval or change the frequency before checking again. The latter is called AFA.

5. Integration of Radio Technology

One of the last steps before a product with integrated wireless technology can be launched on the market, is the certification. Manufacturers of products with integrated RF-technology may only market these with the necessary certification. The following graphics display the three options which are available for integrating wireless technology.

1 Device without certified radio chip and antenna

- + Flexible
- High effort
- High costs

2 Device with external radio dongle

- + Pluggable
- + Easy integration
- Not that flexible

3 Device with certified radio module and antenna

- + Low design effort
- + Fully integrated
- + Low certification effort
- Not that flexible

WHY USING A RADIO MODULE?



HW Hardware

- Powerful RF-Chips
- Design of Ready-to-use Modules
- Antenna-Design
- Edge Castellation allows hand soldering in prototyping or small series production



FW Firmware

- WE-ProWare Radio Stack
- Requirement for approval (CE, FCC, IC, TELEC)
- 20 years of experience
- Developed for industrial and medical requirements
- Easy to handle and to integrate



SW Software

- Plug & Play PC-Software for easy evaluation, testing and updating
- Mobile Apps for easy evaluation & testing
- Design libraries available for fast PCB design for Altium and Eagle
- Software Development Kit (C-Files) for comfortable coding of the HOST-controller system

page: 12

ADDED VALUES

In comparison, there is big potential for saving time and money by using an RF-module instead of the single RF-IC. With a pure HW-RF-module, you can save HW-development resources, since the required circuitry is completely included. An integrated antenna enables an easy integration, even with a minimum of RF knowledge. The software integration, testing and certification effort will be minimized if the firmware is already available, because the FW is linked to module certification.

✓ FASTEN TIME TO MARKET
✓ LOWER DEVELOPMENT COST
✓ INCREASE MARKET SUCCESS

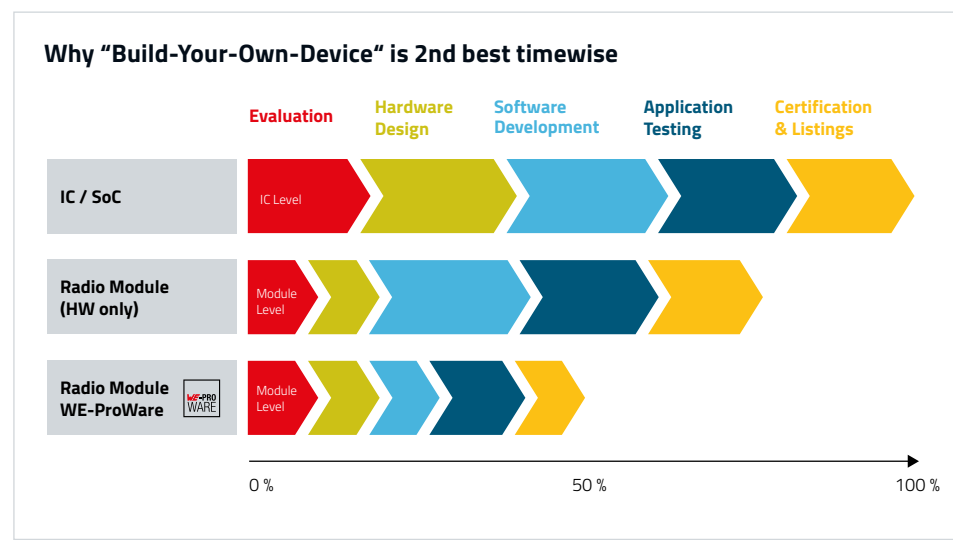
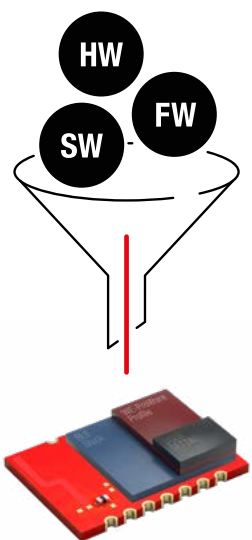

WHY "BUILD-YOUR-OWN-DEVICE" IS 2ND BEST CHOICE

The situation for every system designer, purchaser or similar related functions is always the same. It needs to be compared between an "Off-the-shelf" solution or a "Build-Your-Own-Device" solution. For this process we want to offer a list of key aspects, which Würth Elektronik sees as important to be able to take this decision. We differentiate between three main categories in costs.

	What is necessary to consider?	
	Würth Elektronik "Off-the-Shelf" radio module	Customer "Build-Your-Own-Device"
1. FIXED COSTS		
Module Buy-Price The buying price of the radio module should compare apples with apples. A Würth Elektronik module always comes within a package of hardware (radio module), firmware (µC & RF stack) and the needed software for evaluation. One price includes all features. "Building-Your-Own-Device" needs to consider ADDITIONALLY the following investments.	€€	€
Hardware Development The hardware costs are more than just the Bill of Materials such as microcontroller, IC, oscillator, antenna, PCB, LNA and more. It needs to be taken into account the development itself, the necessary rework during the prototype-to-series phases, the antenna design and possible revisions while the device is already in the market. Using an off-the-shelf solution you don't need to consider all this, since Würth Elektronik is taking care of this for you.		€
Firmware Development The firmware running on radio modules is an accumulation of the one-time software development costs, the recurring costs for software maintenance and required updates and don't forget the necessary documentation. This can simply sum up in a 6-digit Euro investment and following needs to be broken down to each single radio module. Würth Elektronik eiSos modules require a minimum of configuration like communication between module and host microcontroller into the end application from the system designer. A budget of a few days is realistic.		€€
Required Measurement Equipment The final step while taking the radio module into operation is the necessity of measuring all electrical parameters. Therefore, it requires to have measurement tools like a signal generator, spectrum & signal analyzer and oscilloscope available, which represent another 6-digit investment, unless those have already been purchased before.		€€
2. VARIABLE & FIXED COSTS		
Certifications, Conformity, Declaration A product that is to be launched globally must meet the certification or conformity criteria of each country it is to be marketed in. It can be compared with the typical iceberg model, where the measurements, the official certificate or the official stamp only represents the tip. For a "Build-Your-Own-Device" solution, it requires a comprehensive knowledge of all those regulations in each country and following a huge time investment, also for the documentation. Würth Elektronik radio modules come along with the Declaration of Conformity following the Radio Equipment Directive for Europe and on top with a variety of different certifications complying to regulations in the United States, Canada, Japan and some even with the Chinese law. To be on the safe side with the end device, Würth Elektronik recommends a simple and very low cost delta measurement in the final device, as all the documentation will be provided to the customers test lab. Using a USB radio stick from Würth Elektronik makes it even easier – Plug & Play, ready to operate at lowest possible costs.	€	€€
3. OPPORTUNITY COSTS		
Avoid Delayed Market Entry and loose Money Last but not least, deciding for a "Build-Your-Own-Device" solution will set you back several months in most of the cases. Simply, it is missing sales in the market. Instead, using an "Off-the-shelf" radio module solution from Würth Elektronik and starting to sell the end device earlier will accelerate the market release of the end device. It is like gaining time and early profit.		€

HARDWARE

Speed up your time-to-market

Our modules are fully developed, **tested and validated**. The modules include all essential components. Running WE-ProWare radio stack on our modules ensures a reliable communication through standard protocols and proven RF performance.

Open New Markets

One footprint for different frequencies

Most of our modules offer the **same footprint** and form factor. Make use of this feature to easily exchange modules and adapt your application to specific requirements.

Best-in-class integrated PCB antenna

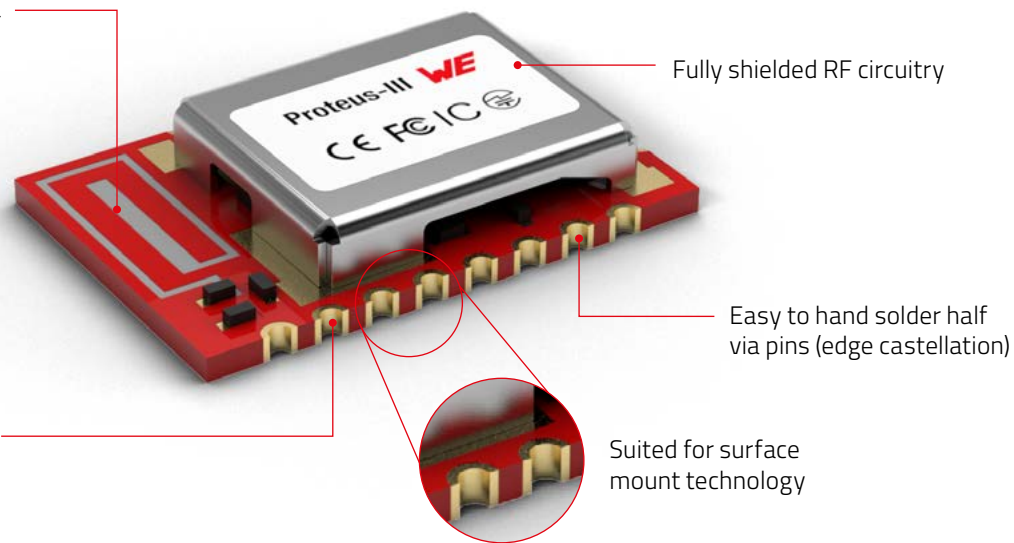

Standard 50 Ohm antenna interface for an external antenna

ADVANTAGES

- ✓ Faster development with a complete RF-module
- ✓ Possibility to work with RF even if there are limited resources in man power or knowledge
- ✓ No antenna design necessary. Integrated antenna!
- ✓ Easy soldering, even by hand for smaller quantities in prototype-phase or for small series
- ✓ Design in guide for all modules
- ✓ Design in support by hardware-, software- and application-engineers

One Hardware Platform

Committing today on a wireless technology for tomorrow seems impossible. Würth Elektronik offers you a high degree of freedom with one radio module footprint for a lot of radio modules to expand your application with different radio protocols at any time without any layout changes. It is one quality proven hardware base, that prevents you from enormous costs of re-design in future already today.

E.g. choose between a Bluetooth®, Wirepas™ or proprietary radio module or the combined variant of proprietary and Bluetooth®.

Design Libraries

- Available for fast PCB-unbundling
- For Altium and Eagle



ANTENNA MATCHING INTEGRATED ANTENNA

Design based on Simulation

The focus of the integrated antenna is for highly miniaturised design. The design ideas are optimized by antenna simulation for best performance. Besides the commonly used parameter of antenna dimensions also the influence of the ground plane of the motherboard is considered in the simulation.

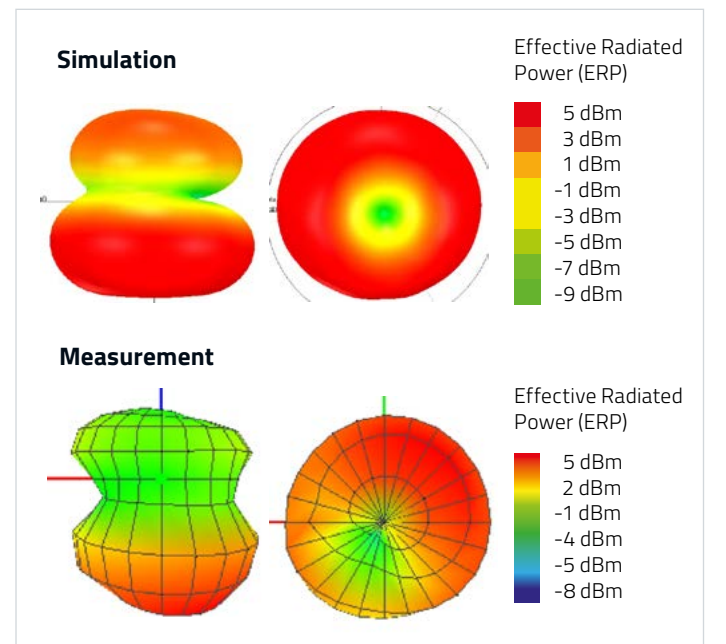
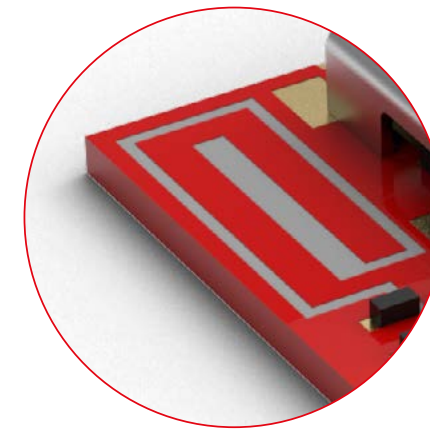

Contact our RF engineers today!
antenna.matching@we-online.com

Verification Evaluation Board

A second step of optimisation is the verification of the design by measuring it's radiated power and characteristics.

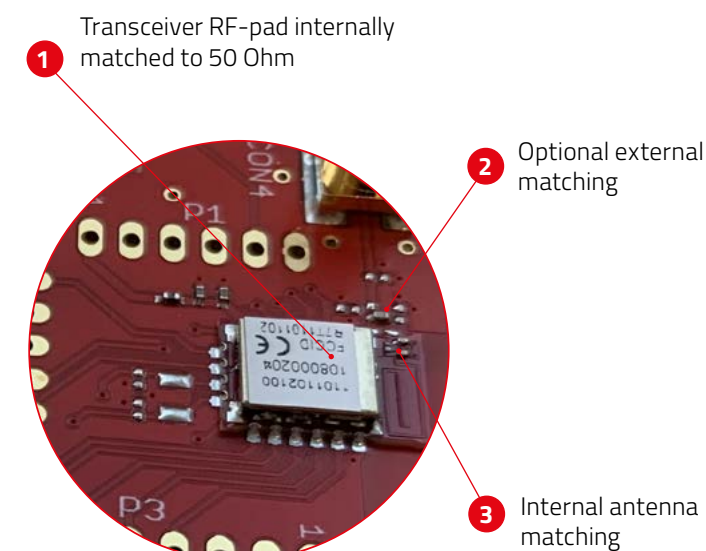

Picture: Evaluation board Thyone-I

Impedance Matching

With the internal antenna matching, the integrated antenna is perfectly matched to the evaluation board.

An external matching is optional to either match any antenna to the module as well as re-matching the integrated antenna to different environmental conditions.

The RF pin is internally matched to 50 Ohm.

ANTENNA MATCHING

SMART ANTENNA SELECTION



Smart Antenna Selection in various Würth Elektronik radio modules enables the user to choose between **two antenna options**:

OPTION 1: On-board PCB antenna

The on-board PCB antenna optimized for operation in the 2.4 GHz band. A simple short between the pins RF and ANT feeds the RF output of the module to the on-board antenna. In this configuration the module does not require any additional RF circuitry.

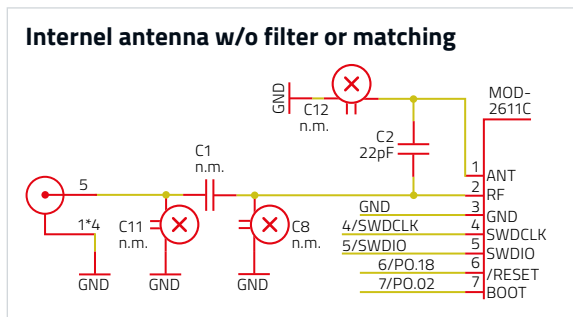

Rematching: i.e. 15-j102 back to 50 Ω

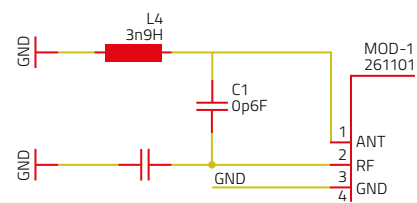

For better performance of the on-board PCB antenna: 22 pF shall be assembled on C28. If additional tuning is needed in the end application, C27 and C26 can be assembled. – The exact values of C27 and C26 shall be specified in the end application corresponding to the individual need.

OPTION 2: External antenna

For applications that use an external antenna, a 50 Ω RF signal on pin RF is provided. In this configuration pin ANT of the module has to be connected to ground and pin RF to the external antenna via 50 Ω feed line.

Coaxial connector w/o filter or matching

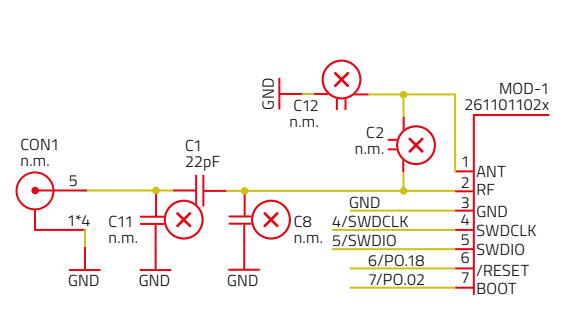

Pi-Filter: i.e. lowpass with cut-off frequency 2.5 GHz and ripple of 0.1 dB, (Chebyshev) adapted to 50 Ohm network

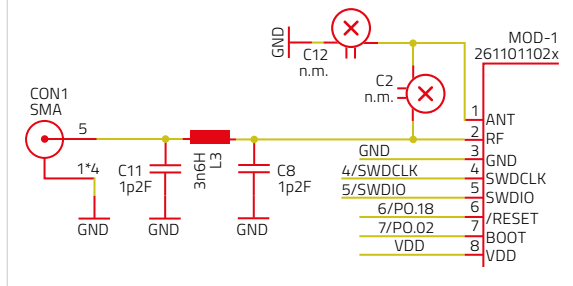

Trace Design

The Trace Design includes layout, schematic and the PCB stack-up. To reference to the Würth Elektronik eiSos' FCC ID it is mandatory to use the trace design.

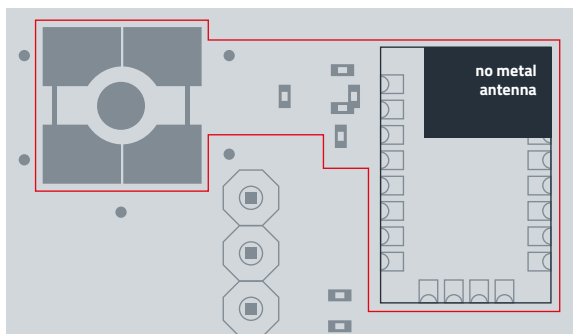

DESIGN AND SOLUTIONS

ANTENNA MATCHING

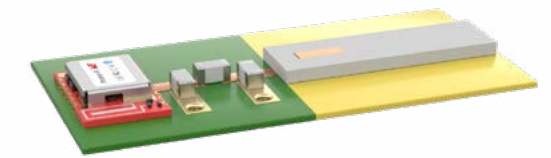

Radio module with chip antenna and matching circuit

What is antenna matching?

Antennas transmit and receive radio signals by converting electromagnetic conducted waves into free space waves and free space waves into conducted waves. In the process, an antenna forms electric and magnetic fields. The generated near field is influenced by the immediate environment. The main influencing factors are metals, batteries/accumulators, casings and human bodies. The position of the chip antenna on the PCB and the PCB size/geometry also affect the near fields, since the PCB together with the chip antenna creates the structure that operates as an antenna.

Due to the influencing factors, the frequency range at which the chip antenna can transmit and receive may be out of tune. With the help of RF inductors and RF capacitors, the chip antenna can be matched to the required frequency range.

The RF inductors and RF capacitors build a matching circuit that match the impedance of the chip antenna to the required frequency range under the influence of the immediate environment. Therefore, it is necessary to make an antenna match as soon as the chip antenna, the immediate environment, the required frequency range, the position of the chip antenna on the PCB or the PCB size/geometry changes. The specified antenna performance requires the correct implementation of the chip antenna for the application. More about this in our design-in guidance on our website.



Antenna matching:
www.we-online.com/antennamatching

Service Process

Our process enables transparent integration into your project plan. If you have any questions about the process or general questions about antenna matching, our service is also available to you.

- Get in touch with us via the online contact form on our website we-online.com/antennamatching
- We review your information and get back to you.
- Please have the following data ready for analysis:
 - **Antenna:** Order code, required operating frequency range, required transmission range
 - **Radio Module:** Order code
 - **PCB:** BOM, circuit diagram, layout, layer structure, layer material
 - **Application:** casing information, immediate environment, environment
- We analyze your data and advise you.
- After successful analysis, the following materials will be required for antenna matching:
 - Complete application with housing and battery/accumulator
 - Two fully assembled PCBs on which the antenna is placed
- We match your antenna and send you a report.
- Your material will be returned.

SERVICES

- ✓ Advice on antenna selection
- ✓ Advice on antenna placement
- ✓ Advice on selection of the matching circuit for the antenna with RF-inductors and -capacitors
- ✓ Measurement of antenna S11 parameters: return loss (RL), voltage standing wave ratio (VSWR) and RL efficiency
- ✓ Antenna simulation models

PRODUCT OVERVIEW

ANTENNAS

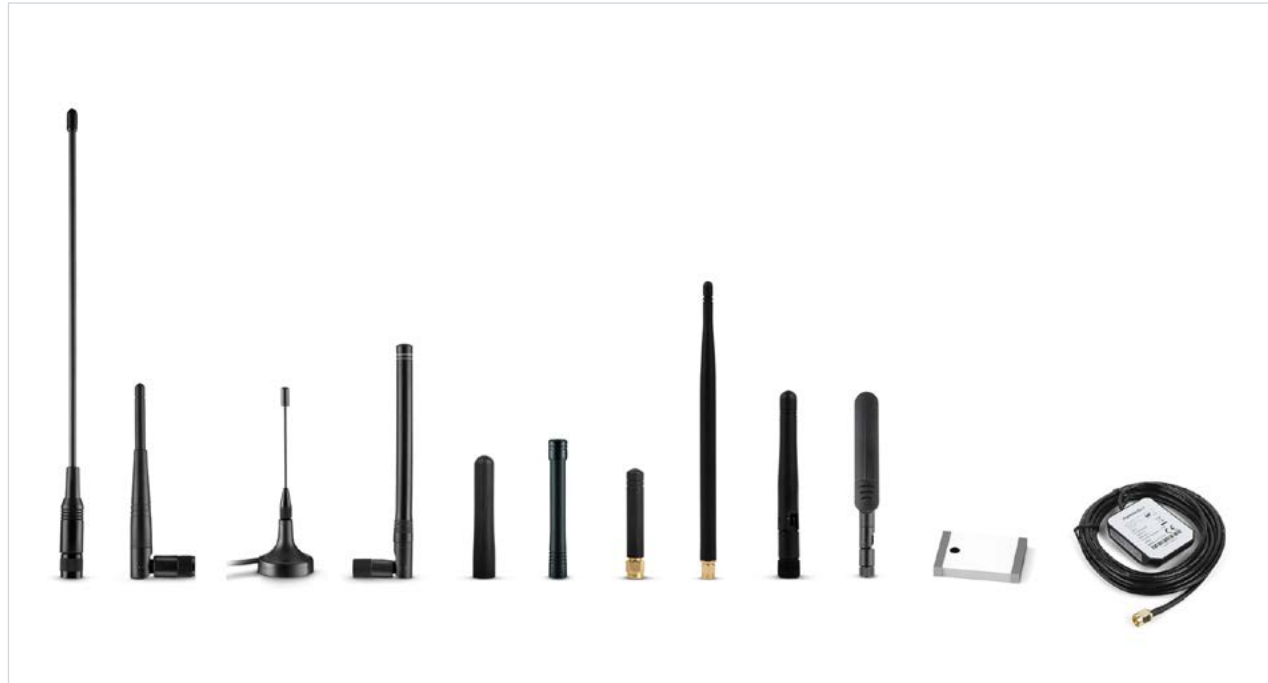

Antennas to Enhance Wireless Solutions

Antennas play an important role in radio modules, significantly influencing their performance and overall effectiveness in wireless communication.

Selecting the right antenna for a radio module ensures that the transmitted and received signals are optimized, resulting in improved communication quality.

By providing antennas along with radio modules, we empower our customers to achieve superior wireless connectivity, making your devices more reliable and efficient.

Order Code	Name	Frequency in MHz
2600130012	Helike-II	169
2600130041	Herse	433
2600130081, 2600130082	Hyperion-I, Hyperion-II	868
2600130086	Hermippe-III New	855 - 915
2600130083	Hydra-I	915
2600130016	Halimede-I	1575 - 1610
2600130021	Himalia	2400 - 2500
2600130084	Hati-I	700 - 2700



Antennas for Radio Modules:
www.we-online.com/wirl-antennas



LTCC antennas:
www.we-online.com/en/components/products/WE-MCA

WÜRTH ELEKTRONIK

RF COMPONENTS

Multilayer Chip Antenna

- Extremely low profile
- Power capacity: 5 W max.
- Omni-directional
- Operating temperature: -40 C to +85 C
- High gain
- Wireless communication applications: GSM, WLAN, Bluetooth, Home RF, IoT



we-online.com/katalog/en/WE-MCA

Unlike custom designed PCB antennas, the WE-MCA has a consistent omnidirectional radiation pattern. This gives flexibility and variation in the positioning of the antenna in the application.

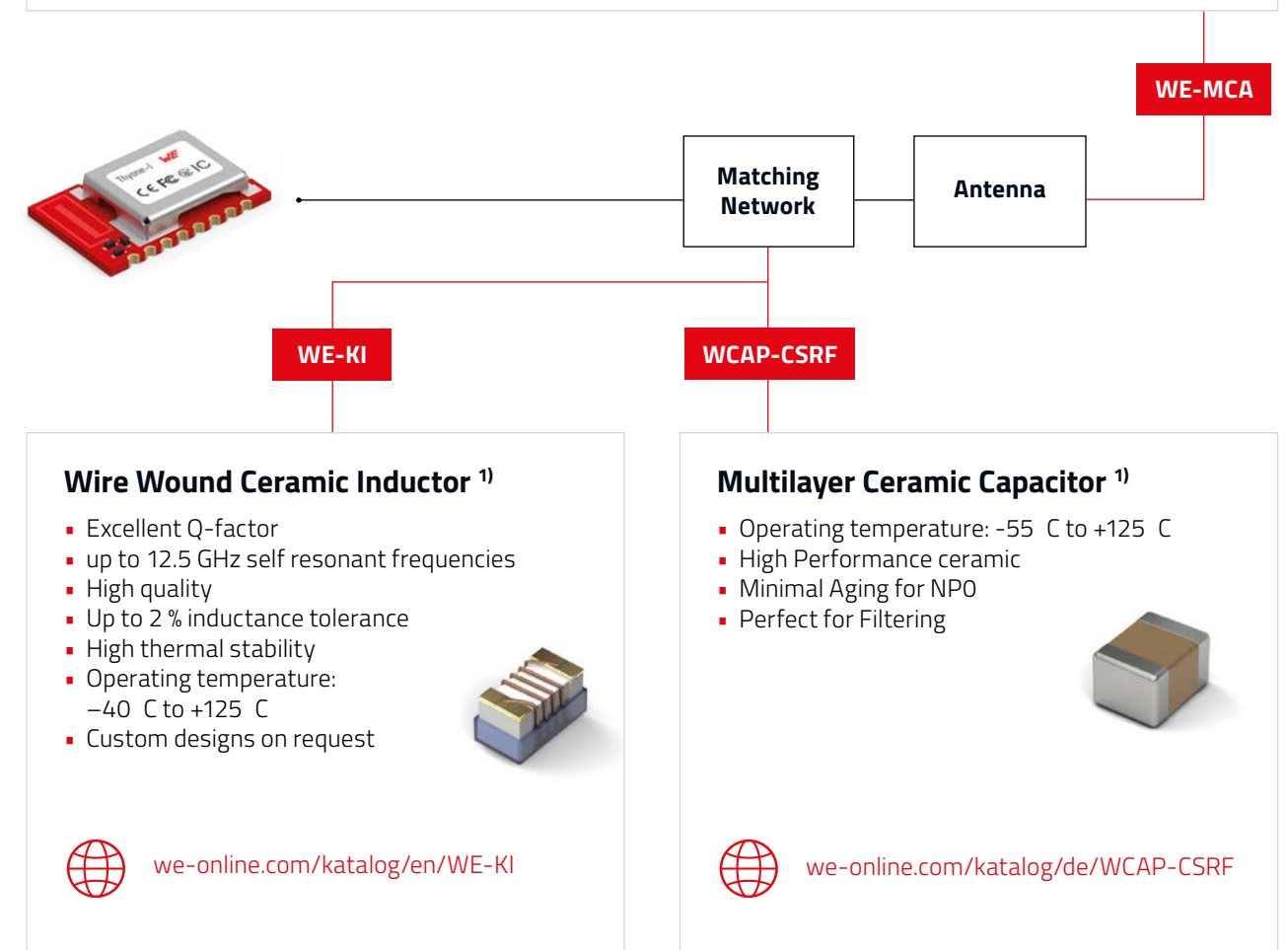

Wire Wound Ceramic Inductor ¹⁾

- Excellent Q-factor
- up to 12.5 GHz self resonant frequencies
- High quality
- Up to 2 % inductance tolerance
- High thermal stability
- Operating temperature: -40 C to +125 C
- Custom designs on request

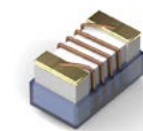

we-online.com/katalog/en/WE-KI

Multilayer Ceramic Capacitor ¹⁾

- Operating temperature: -55 C to +125 C
- High Performance ceramic
- Minimal Aging for NPO
- Perfect for Filtering



we-online.com/katalog/de/WCAP-CSRF

¹⁾ Modelithics® libraries available for Advanced Design System (ADS), Genesys and also for AWR Microwave Office

AppNotes

WE-MCA Multilayer Chip Antenna Placement & Matching
we-online.com/ANP057

LC Filter Design With MLCCs: Why The Applied Voltage Matters
we-online.com/ANP062

IMPROVE YOUR DESIGN GET RID OF NOISE

Noise at 2.4 / 5.0 GHz

Noise can interfere with the extremely sensitive wireless channels operating at 2.4 / 5.0 GHz bands. Therefore, it is important to consider a holistic design of the full application.

Communication Interfaces – Source of Noise

Noise can interfere with the extremely sensitive wireless channels operating at 2.4 / 5.0 GHz bands.

- Communication interfaces radiate noise on a very broad spectrum which can interfere with the WiFi signal
- This can lead to loss of the WiFi signal

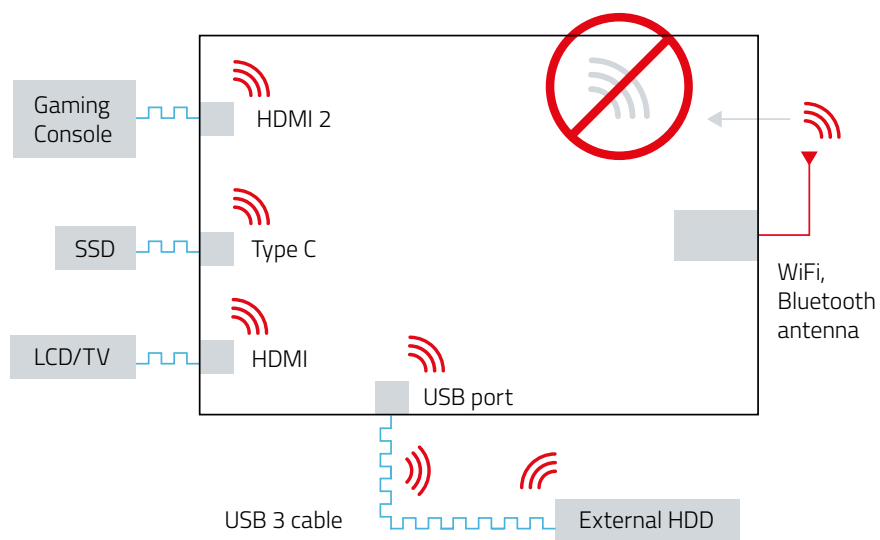

Signal Integrity and Increase in Data Speed of Highspeed interfaces

Signal integrity defines the quality of an electrical signal and refers to the challenges that arise due to high frequency data transmission. With the high switching speeds of the modern digital I/O interfaces, we are now able to achieve high data rates and bandwidth. At the same time, noise is a big concern for the integrity of these high frequency digital signals.

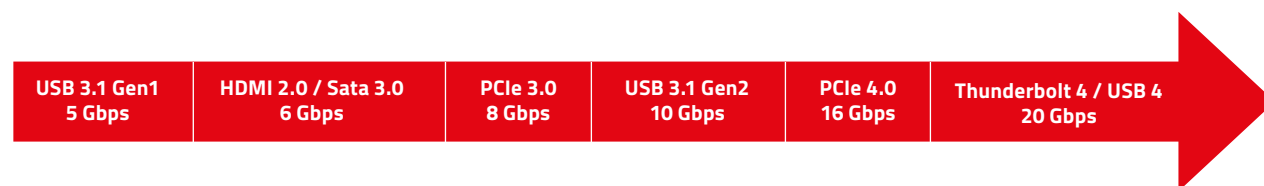

Common Mode Chokes - reduce emissions, increase noise immunity

Common mode filters/chokes are a very effective way of protecting the data lines against noise interference, while reducing emissions at the same time. Choosing the appropriate common mode choke for a high-speed differential interface, requires knowledge about both the application and the filter itself.

WE-CCMF

Ceramic Common Mode Filter:

- Ceramic based choke that works on the principle of the transmission line theory
- Complex inner resonant structure ensures high common mode suppression at wireless frequencies (2.4 & 5.0 GHz)
- Keeps the differential signal intact

we-online.com/katalog/en/WE-CCMF

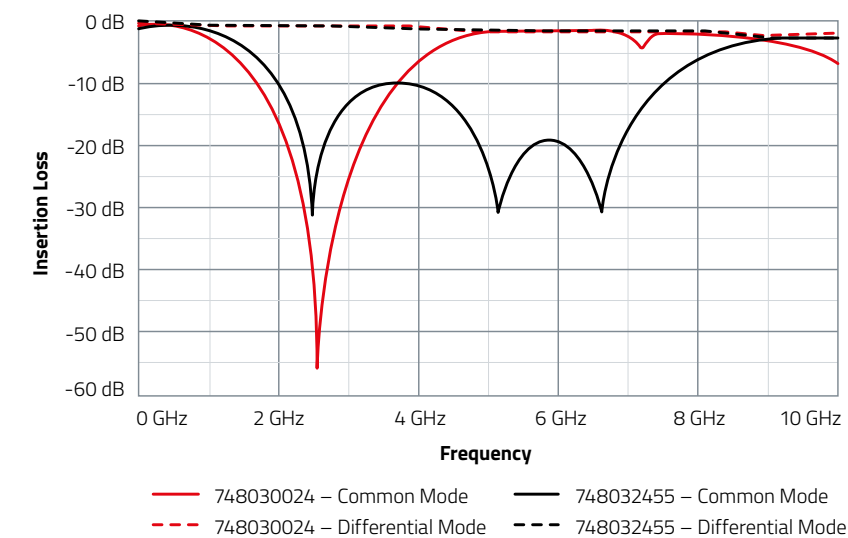
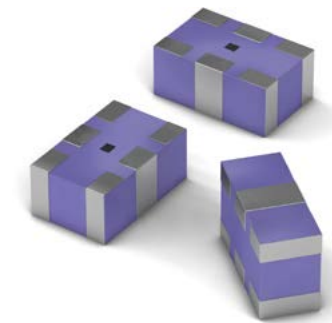

FIRMWARE: WE-PROWARE AS OPERATING SYSTEM

**EXAMPLE:
BLE Module**

Fully featured & "BLE qualified" software stack

SPP-like profile (TX & RX characteristic) DIS, Security Modes, Bonding, FOTA, Automatic BLE Role switch, Low Power Optimization

**EXAMPLE:
Proprietary Module**

Fixed hardware design "RF module"
→ Small formfactor
→ Robust RF modules

Individualization of parameters to match customer applications e.g. configuration of
→ UART baudrate
→ RF output power

Offers Easy-to-Use Command Interface among other features

WE-PROWARE

More on page 142

FIRMWARE: WE-PROWARE

One solution with full flexibility

Our Firmware and radio stack WE-ProWare offers full flexibility through the possibility of using different radio profiles and/or interfaces while being an off-the-shelf software code to enter the wireless world immediately. For a simple integration, we offer an API to match your needs with the offerings from the Firmware WE-ProWare.

Profiles

Instead of writing software code, select options (=profiles). The usable profiles offer high flexibility in:

- Network topology
- Data rate
- Throughput
- Range
- Energy consumption

API (Application Programming Interface)

- Offers communication directly to the module
- Simple AT-Commands, well known and usable with nearly every microcontroller, regardless of its size

Radio Stack

- Bluetooth® LE Stack for easy communication with smart devices
- WiFi Stack guarantees high data rates and IP based communication
- Proprietary stack developed for industrial and medical requirements
- LTE cellular radio stack for global connectivity

Interface

Different Interfaces available suiting every application:

- UART
- SPI
- I²C

RADIO STACK & FIRMWARE OPTIONS

The best Wireless Solution for you – You can choose between the following options:

1. STANDARD FIRMWARE

- RF module comes with a standardized firmware
- RF module is subject to further firmware development
- 100% verified, electrical tested and validated
- Update functionality given (UART, FOTA, ...)
- Packaged in Tape & Reel, ESD und MSL conform



2. BUILD YOUR OWN FIRMWARE

Get every module without WE Firmware to bring your own solution on it.

- RF module comes without any standardized firmware
- 100% electrical testing on customer request
- RF module will have a standard part number
- Packaged in Tape & Reel, ESD und MSL conform



3. FIRMWARE FREEZE

A firmware freeze guarantees a static behaviour of the module and no change in the module at all.

- RF module comes with a standardized firmware
- RF module is NOT subject to further firmware development
- RF module will have a fixed revision of the firmware e.g. 1.3.1
- RF module will have a unique part number
- 100% verified, electrical tested and validated
- Packaged in Tape & Reel, ESD und MSL conform

4. CUSTOM

A fully customized product with your dedicated application implemented on the module. This might require Würth Elektronik to offer design consultancy services and the product is not available ex stock.

- RF module comes with a custom firmware
- RF module will have a unique part number
- 100% electrical testing on customer request
- Packaged in Tape & Reel, ESD und MSL conform
- We can upload your Firmware in our production process to the WE Hardware



A special service for every customer:

5. INDIVIDUALIZED ADAPTION (USER SETTINGS)

We align our standard firmware to your requirements which simplifies your production process.

- RF module comes with a standard firmware
- User Settings adaptations defined by customer
- Continuous & further firmware development only on customer request
- Individualized Adaption (User Settings)
- Firmware freeze on customer request
- RF module will have a unique part number
- 100% verified and electrical tested
- Packaged in Tape & Reel, ESD und MSL conform

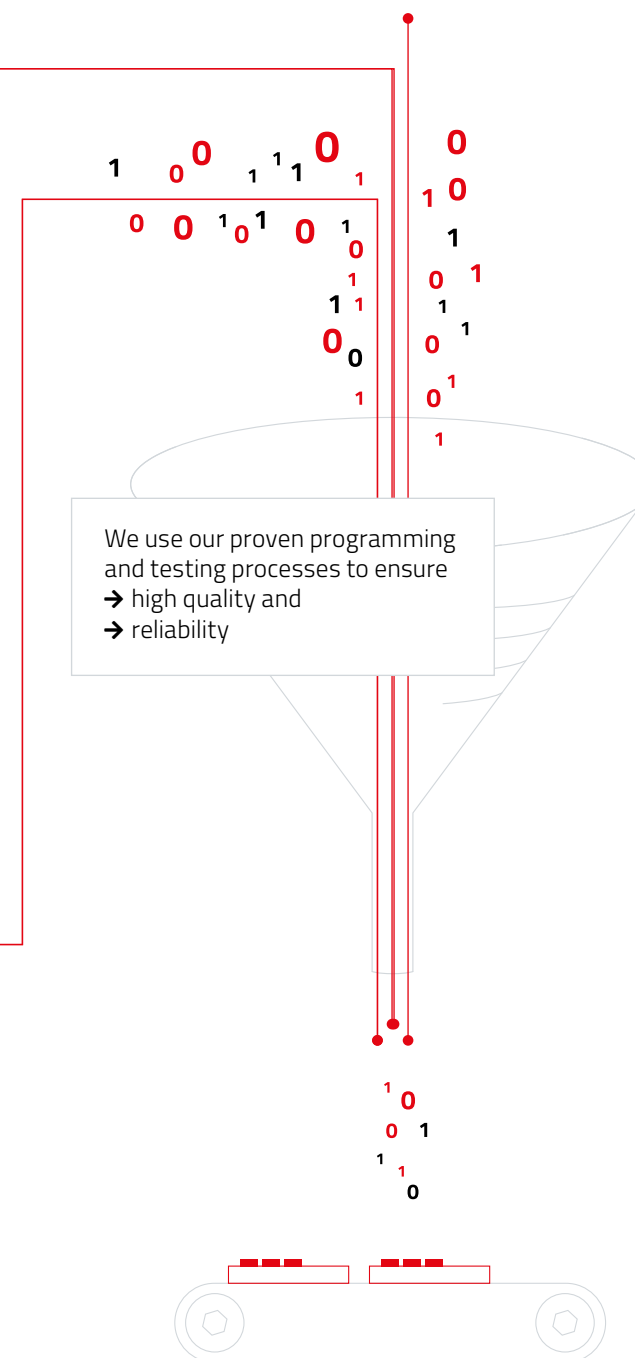

Exemplary UserSettings

Setting	Calypso	Proteus
Advertising timing		✓
Beacon options		✓
Connection timing		✓
Device Name		✓
Device Information Service Options/Fields		
High Throughput mode on/off		
Profile Options (Base UUID)		✓
Scan options		✓
Long Range Connect		
WLAN country (EU, US, JP)	✓	
WLAN mode (STA, P2P/WiFi direct)	✓	
WLAN P2P Parameters	✓	
WLAN Policy (Power, Connection)	✓	
WLAN Provisioning Parameters *	✓	
SNTP Time Servers	✓	
WLAN STA Profile(s)	✓	
<hr/>		
Radio TX Power	✓	✓
Security options	✓	✓
Sniffer mode on/off		
StaticPasskey (128 bit)		✓
UART data rate		✓
UART data rate+parity	✓	
UART flow control on/off (RTS/CTS)		✓
OpMode (Command or Transparent UART)		✓
Clear Channel Assessment/Listen before Talk		
GPIO control		
UART data rate		
satellite system selection		
Protocol (NMEA or OSP)		
update rate (typ. 1Hz)		
Firmware description (e.g. Customer name)		
Secure Boot Key	✓	
Image Authentication Key	✓	✓



Do you have a need for one of the mentioned customizations? Get in contact with us. We will find out, what fits best for you! Contact your local sales or email to: wcs@we-online.com

BUILD YOUR OWN FIRMWARE

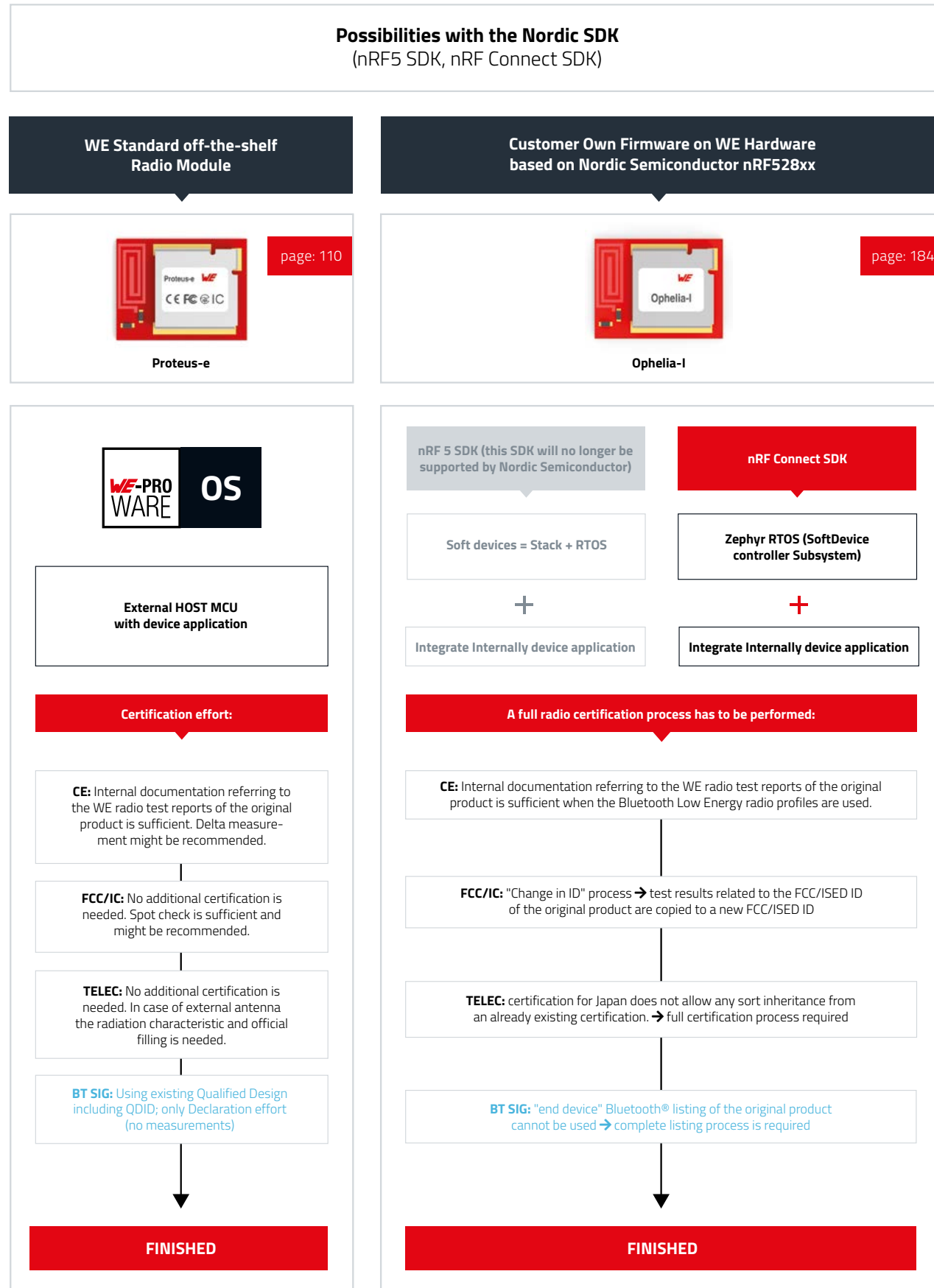

HOW TO GAIN THE RADIO CERTIFICATION FOR A RADIO MODULE

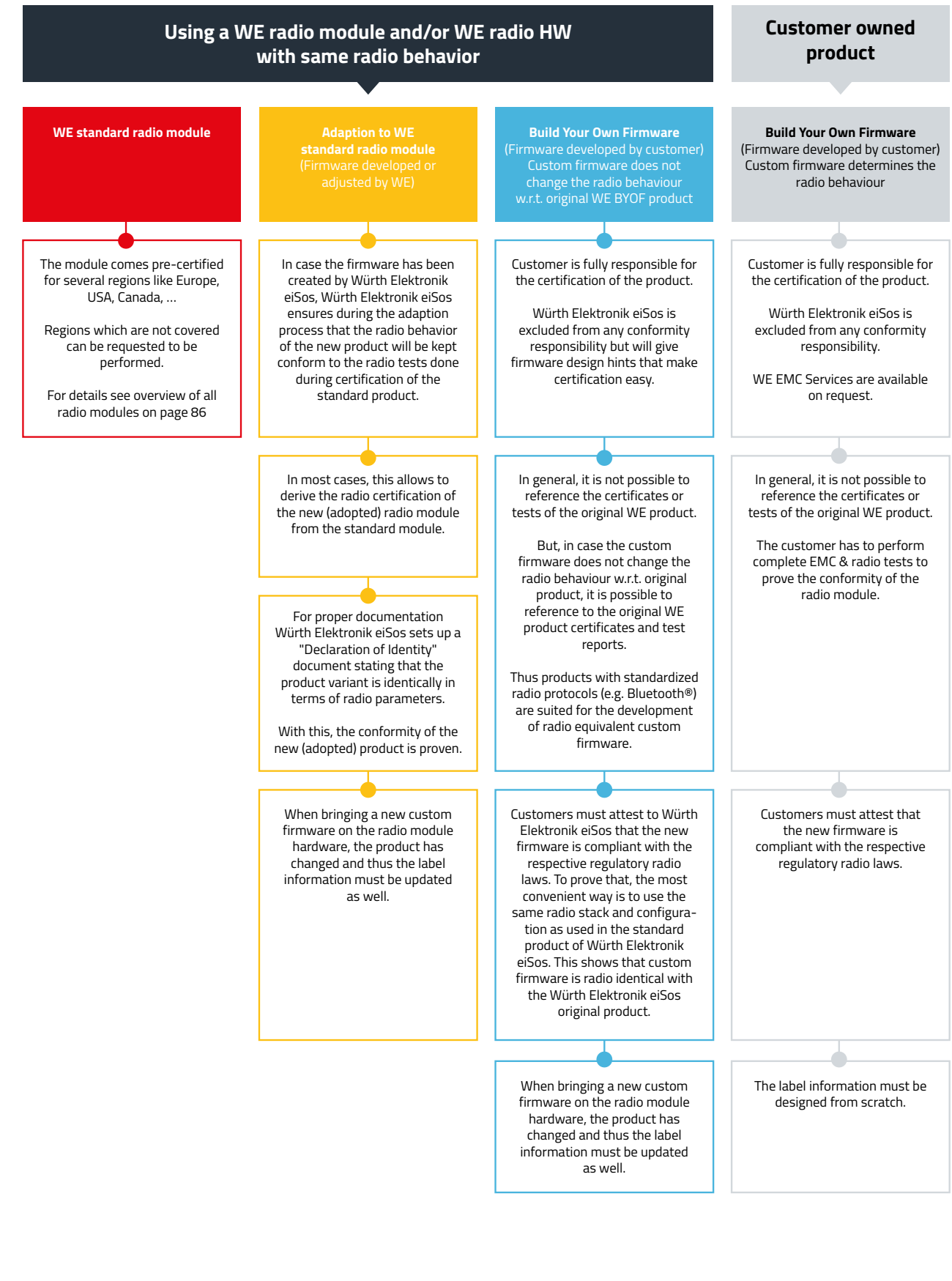

CERTIFICATION & CONFORMITY

Which Certification Rules apply where?

A product that is to be launched globally must meet the certification or conformity criteria of each country it is to be marketed in. There is no worldwide certification applicable to all countries. The following presents the various certification systems.

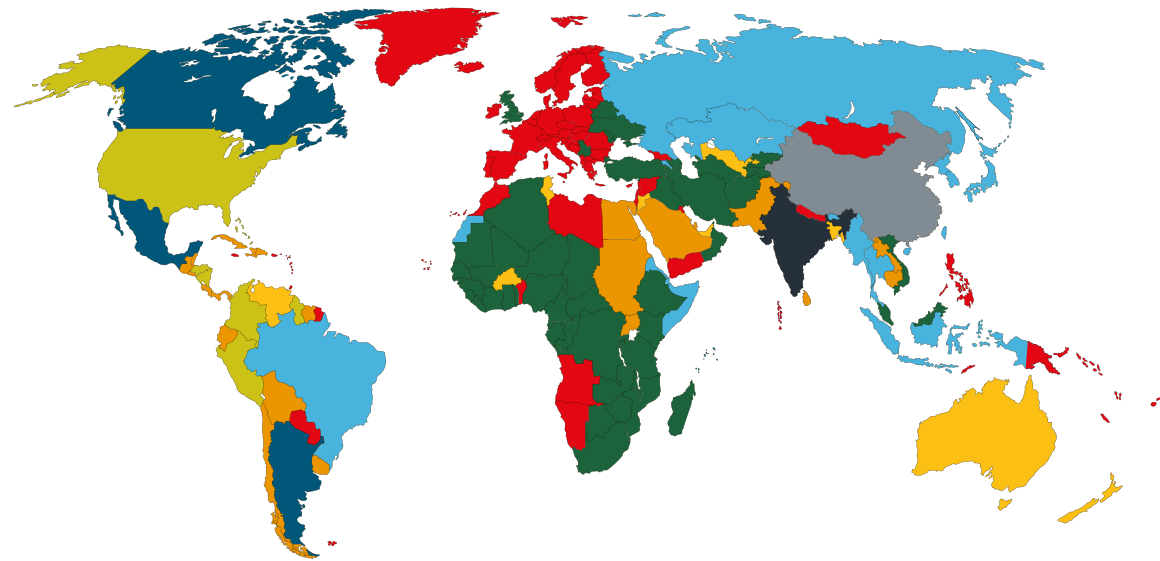

- CE
RED
- FCC
- National
(e.g. Japan
TELEC)
- RED
National
- RED
FCC
- FCC
National (e.g.
Canada ISED)
- RED
FCC
National
- ETA-WPC
National
- SRRC
National

Different Certification Systems



For products distributed in the European market, the CE mark is required. The manufacturer applies the CE mark after fulfilling the Radio Equipment Directive (RED). The tests may be conducted either by the manufacturer himself or by an accredited laboratory. As self-declarant, the manufacturer is responsible for the products conformity to legal restrictions and regulations.



For all other markets, national regulations apply. For example, a product introduction in Canada or Japan requires ISED or TELEC certification. Most countries are close to CE or FCC. Deadlines, requirements and measurements can differ.



In North America, however, products with wireless technology require FCC certification. A certification through a verified authority with measurements is mandatory.



These are example of national certification systems close to CE or FCC. IC is a certification through a Canadian authority, but the testing is similar to FCC, while UKCA is working with designated EU standards and even accepting radio goods with CE marking.

Certificate Examples



The **manufacturer** declares, that...



The **regulation body** certifies that...

Benefits of Certification and Conformity

Be smart and ensure that your product will pass the certification process!

Obtain assurance – Pre-certification is half the battle won and reduces the final test effort.

Save time and money – the likelihood that the end product will pass, is much greater with pre-certification.

All Würth Elektronik radio modules are either certified and / or declared for conformity. This simplifies the approval process of such a radio module within the end-application significantly.

OVERVIEW OF PRODUCTS

National Requirements Matrix

Order Code (part number)	Product Name	Frequency [MHz]	Match code (Product Series)	Product Information (Article Description)	CE EU	FCC USA	IC Canada	TELEC Japan	SRRC China	WPC India	Australia	Brazil	Other countries
2615011136000	Adrastea-I	800-1800 / 1560-1610	WIRL-CLTI	LTE-M / NB-IoT Cellular module with GNSS	yes	possible	possible	no	possible	on request	on request	possible	on request
2612011022000	Ophelia-I	2400	WIRL-NFW2	2.4 GHz radio module without firmware	yes	yes	yes	yes	yes	yes	yes	possible	on request
2617011025000	Stephano-I	2400	WIRL-COMB	Bluetooth® Low Energy 5.0 & IEEE 802.11 b/g/n 2.4 GHz	yes	yes	yes	yes	possible	possible	possible	possible	on request
2608011024000	Proteus-I	2400	WIRL-BTLE	Bluetooth® LE 4.2 with integrated antenna	yes	yes	yes	yes	yes	possible	possible	possible	on request
2608011124000	Proteus-I	2400	WIRL-BTLE	Bluetooth® LE 4.2 with RF pad	yes	yes	yes	yes	no	possible	possible	possible	on request
2606031021000	Thalassa	2400	WIRL-PRO2	2.4 GHz proprietary module with integrated antenna	yes	yes	yes	no	no	possible	possible	possible	on request
2606031121000	Thalassa	2400	WIRL-PRO2	2.4 GHz proprietary module with RF pad	yes	yes	yes	no	no	possible	possible	possible	on request
2606031321000	Thalassa	2400	WIRL-PRO2	2.4 GHz proprietary module with U.FL connector	yes	yes	yes	no	no	possible	possible	possible	on request
2611011024020	Setebos-I	2400	WIRL-PRO2	2.4 GHz radio module with proprietary and Bluetooth® LE 5.1 radio protocol	yes	yes	yes	possible	possible	yes	possible	possible	on request
2608011024010	Proteus-II	2400	WIRL-BTLE	Bluetooth® LE 5.0 with integrated antenna	yes	yes	yes	yes	possible	yes	possible	possible	on request
2611011024000	Proteus-III	2400	WIRL-BTLE	Bluetooth® LE 5.1 with smart antenna selection	yes	yes	yes	yes	yes	yes	possible	possible	on request
2611011024010	Proteus-III- SPI	2400	WIRL-BTLE	Bluetooth® LE 5.1 with SPI interface	yes	yes	yes	yes	possible	yes	possible	possible	on request
2611011020000	Ophelia-III	2400	WIRL-NFW2	2.4 GHz	yes	yes	yes	yes	yes	yes	yes	possible	on request
2612011024000	Proteus-e	2400	WIRL-BTLE	Bluetooth® LE 5.1 module	yes	yes	yes	yes	possible	yes	possible	possible	on request
2610011025000	Calypso	2400	WIRL-WIFS	2.4 GHz WiFi module	yes	yes	yes	possible	possible	yes	possible	possible	on request
2611011021000	Thyone-I	2400	WIRL-PRO2	2.4 GHz proprietary module; smart antenna selection	yes	yes	yes	yes	possible	yes	possible	possible	on request
2612011021000	Thyone-e	2400	WIRL-PRO2	2.4 GHz proprietary module; smart antenna selection	yes	yes	yes	possible	possible	possible	possible	possible	on request
2611011021010	Thetis-I	2400	WIRL-PRO2	2.4 GHz Wirepas Mesh module	yes	yes	yes	possible	possible	yes	possible	possible	on request
2608011124010	Proteus-II	2400	WIRL-BTLE	Bluetooth® LE 5.0 with RF pad	yes	yes	yes	yes	on request	yes	on request	possible	on request
2603011021000	Triton	2400	WIRL-PRO2	2.4 GHz proprietary module with integrated antenna	yes	yes	yes	possible	possible	yes	possible	possible	on request
2603011121000	Triton	2400	WIRL-PRO2	2.4 GHz proprietary module with RF pad	yes	yes	yes	possible	possible	yes	possible	possible	on request
2611059021001	Thyone-I FeatherWing	2400	WIRL-EVAL	Proprietary 2.4 GHz RF-Module Connection	yes	yes	yes	possible	yes	on request	on request	possible	on request
2610039025001	Calypso FeatherWing	2400	WIRL-EVAL	WiFi-Connection 2.4 GHz	yes	yes	yes	possible	yes	on request	on request	possible	on request
2609041191000	Themisto-I	915	WIRL-PRO9	915 MHz proprietary module with RF pad	no	yes	yes	modified	no	no	modified	possible	on request
2607021191000	Telesto-I	915	WIRL-PRO9	915 MHz proprietary module with RF pad	no	yes	yes	no	no	modified	modified	possible	on request
2607021191010	Telesto-II	915	WIRL-PRO9	915 MHz proprietary module with RF pad	no	yes	yes	no	no	modified	modified	possible	on request
2609011091000	Telesto-III	915	WIRL-PRO9	915 MHz proprietary module with integrated antenna	no	yes	yes	modified	modified	modified	modified	possible	on request
2609011191000	Telesto-III	915	WIRL-PRO9	915 MHz proprietary module with RF pad	no	yes	yes	modified	modified	modified	modified	possible	on request
2609031181000	Thebe-II	869	WIRL-PRO8	868 MHz proprietary module with RF pad	yes	no	no	no	no	no	no	no	on request
2605041183000	Metis-I	868	WIRL-WMB8	868 MHz wM-BUS module	yes	no	no	no	no	no	no	no	on request
2607021183000	Metis-II	868	WIRL-WMB8	868 MHz wM-BUS module	yes	no	no	no	no	no	no	no	on request
2607056283011	Metis-II	868	WIRL-WMB8	868 MHz wM-BUS radio simulation USB-Stick	yes	no	no	no	no	no	no	no	on request
2607057283011	Metis- Analyzer Tool	868	WIRL-WMB8	868 MHz wM-BUS radio Analyzer USB-Stick	yes	no	no	no	no	no	no	no	on request
2605041181000	Tarvos-I	868	WIRL-PRO8	868 MHz proprietary module with RF pad	yes	no	no	no	no	modified	no	no	on request
2607021181000	Tarvos-II	868	WIRL-PRO8	868 MHz proprietary module with RF pad	yes	no	no	no	no	modified	no	no	on request
2609011081000	Tarvos-III	868	WIRL-PRO8	868 MHz proprietary module with integrated antenna	yes	no	no	no	modified	modified	no	no	on request
2609011181000	Tarvos-III	868	WIRL-PRO8	868 MHz proprietary module with RF pad	yes	no	no	no	modified	modified	no	no	on request
2618011181000	Daphnis-I	868	WIRL-LoRa®	868 MHz Long-Range-WAN module with RF pad	yes	modified	modified	on request	on request	on request	on request	no	on request
2605031141000	Thadeus	434	WIRL-PRO4	434 MHz proprietary module with RF pad	yes	no	no	no	no	no	possible	no	on request
2607011111000	Titania	169	WIRL-PRO2	169 MHz proprietary module with RF pad	yes	no	no	no	no	possible	on request	no	on request
2607011113000	Mimas-I	169	WIRL-WMB1	169 MHz wM-BUS module	yes	no	no	no	no	possible	on request	no	on request

detailed description see next page

OVERVIEW OF PRODUCTS TO NATIONAL REQUIREMENTS MATRIX

Yes

Module fulfills national requirements, testing, certification and/or self declarations are done. Module fulfills national requirements. If required testing, certification and/or declaration of conformity are done.

Yes also includes products that have not been tested, certified or declared to be conform in case of not required.

Some examples:

- **Evaluation boards** are excluded from radio conformity approach in many countrys.
- **Receiver only modules** are exempted from radio conformity approach in some countrys.

No

Module is not suitable to fulfill national requirements, e.g.: frequency range, transmitter on time, output power, hopping, bandwidth.

Possible

Module is expected to fulfill national requirements, but no testing, no certification and/or no self declaration was done.

Modified

Module is not fulfilling national requirements but is suitable to do with some modifications that can only be implemented in a new or custom product.

On Request

The requirements must be checked depending on the project.

Brazil

Certification in Brazil is valid two years. Therefore we decided to not certify modules. We support customers with exchange to the authority (fillings and confidential docs).

United Kingdom (UKCA)

With the intention of the British government to legislate in spring 2024 the indefinitely recognition of EU requirements, including CE marking for 21 product regulations, amongst others the Radio Equipment Regulations no further conformity prove or marking than CE is needed.

<https://www.gov.uk/guidance/using-the-ukca-marking>

NOT MENTIONED IN YES OR NO



Requirements have to be checked for each product and each country.

2.4 GHz

- Existing products usually can be certified without product change
- Retesting is often required
- Big difference in cost, depending on the national requirements. Average 10k € invest.
- Big difference in afford, from 3 Month to more than 1 year if legal responsibilities have to be settled

Sub GHz (<1 GHz)

- To meet the national requirements the module must be changed
- New product, new firmware. Beside certification effort the development effort has to be taken into account
- Roadmap Project

Country specific requirements

Radio conformity and Certification

- There are national requirements on end devices, modules and components
- Radio requirements usually are applicable on module level and on end device level, not on component level
- Module must comply to be legally sold

Build Your Own Firmware Modules - Open Modules - Ophelia / Orthosie

„0“ = 0 [zero] Certification?

- The Ophelia Series does not contain firmware
- Without firmware the product is considered as component, as like the chipset it has no transmitting or receiving functionality implemented
- No radio certification needed

EMS Business

- Electronic Manufacturing Service produces the end device in a country where the module is not complying to national laws but exporting the end device into a country which valid certification/proven conformity
- Customer signs export to certified country document

CELLULAR



91
96
100

FUNDAMENTALS

Cellular - an Overview

LTE (Long Term Evolution) is a cellular communication standard, which operates in licensed spectrum. LTE is also referred to as fourth generation ("4G") of cellular communication technology. The standards for LTE are defined by 3rd Generation Partnership Project (3GPP). 3GPP is a worldwide standards organization that develops protocols/standards for cellular telecommunications.

LPWAN cellular technologies are for low-power, low transmitting speeds, low-cost module and devices with low data usage per month, and wide area coverage. Existing cellular technologies were not designed to cater low power application, hence cellular LPWAN technologies cover scenarios for which existing mobile network technology is not suitable. These cellular LPWAN refers to low power wide area networks (LPWAN) in licensed spectrum.

3GPP specified LTE-M (LTE-MTC) and NB-IoT (Narrow-Band IoT) to address the fast-expanding market for low power wide area network (LPWAN) connectivity.

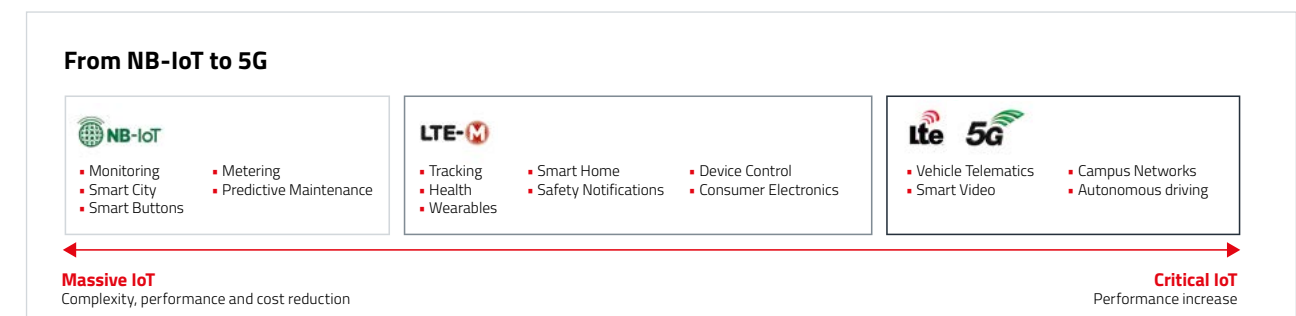
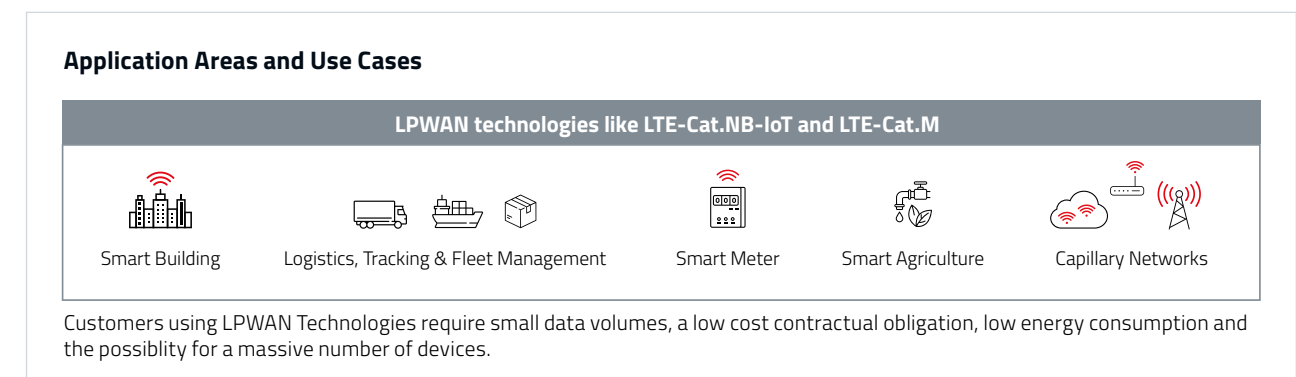
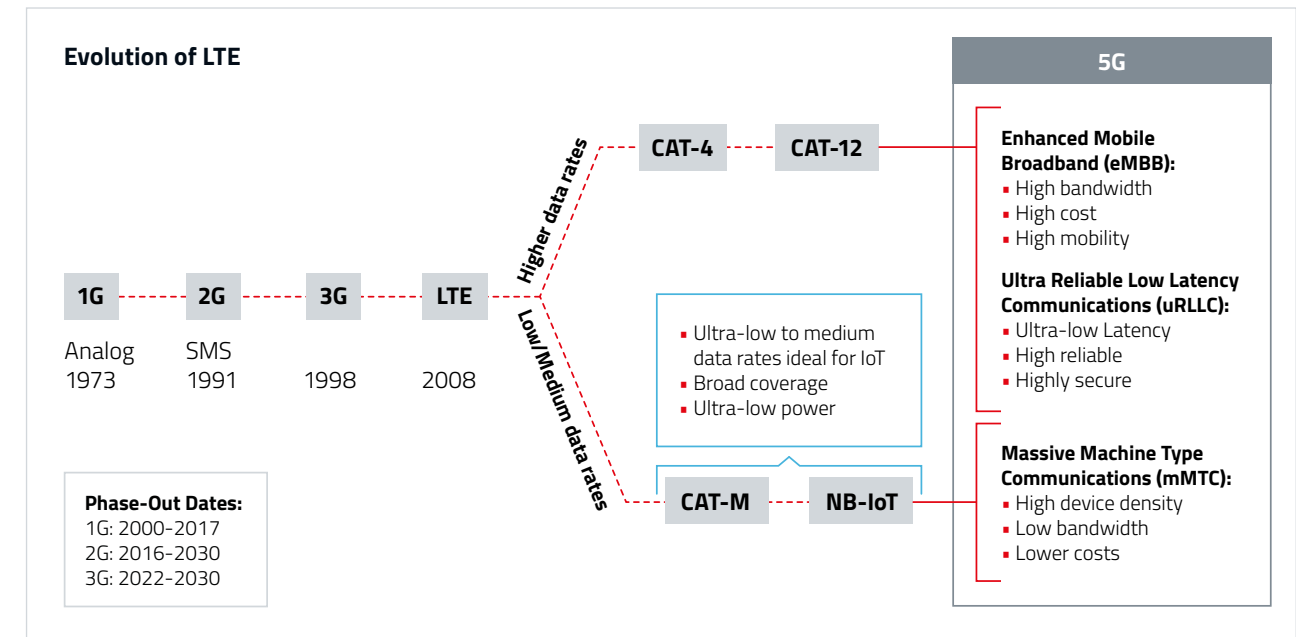

IOT CONNECTIVITY OPTIONS

The Right Choice

The main purpose of any IoT solution is to get data from the field to the cloud where analysis of the same generates the desired value proposition for the application. With a wide range of IoT connectivity options available, the connectivity decision is increasingly based on the cost, security, coverage, power usage and the potential throughput of the connectivity. Multiple IoT connectivity options are available and at the broader level these solutions can be categorized into two types:

- a) Short range wireless connectivity solutions and
- b) Long range wireless connectivity solutions

For few applications, both short range and long range solutions can fit but application's requirements and environments determines which connectivity solution shall be used.

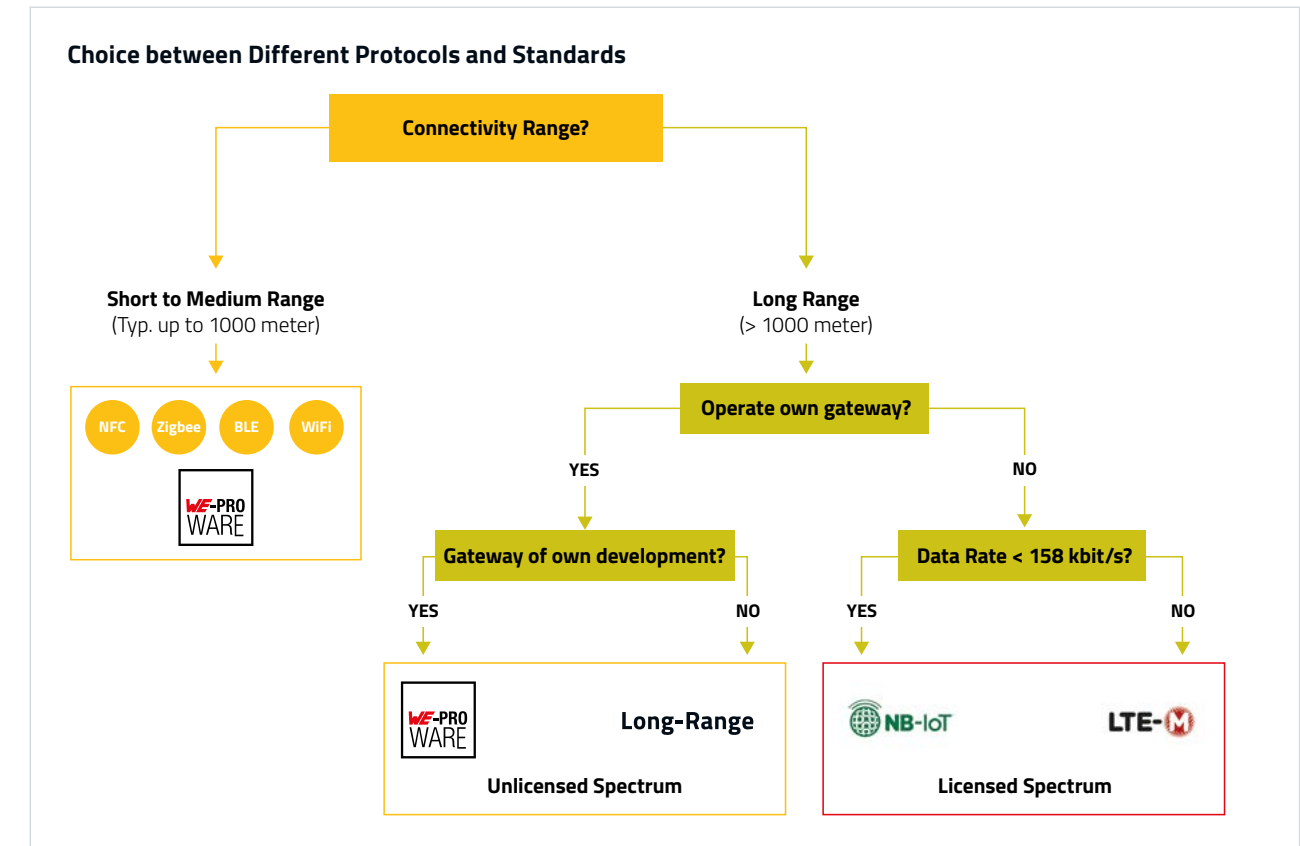
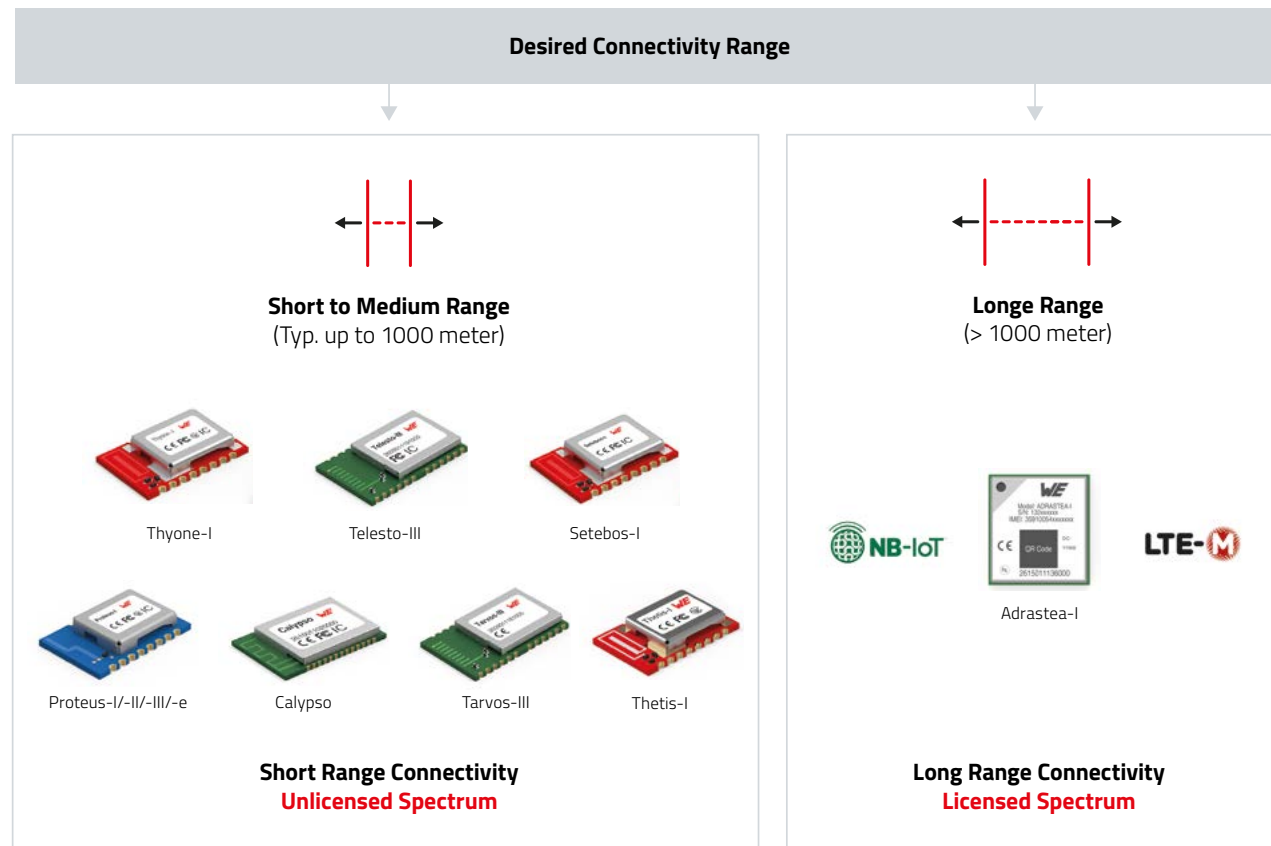
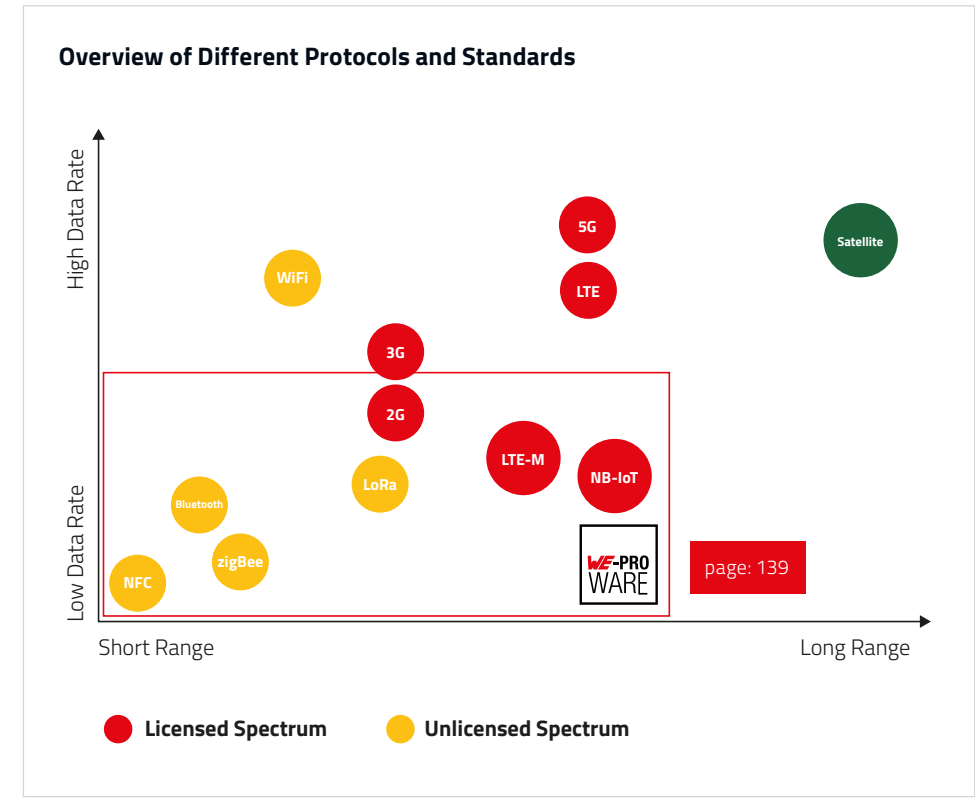
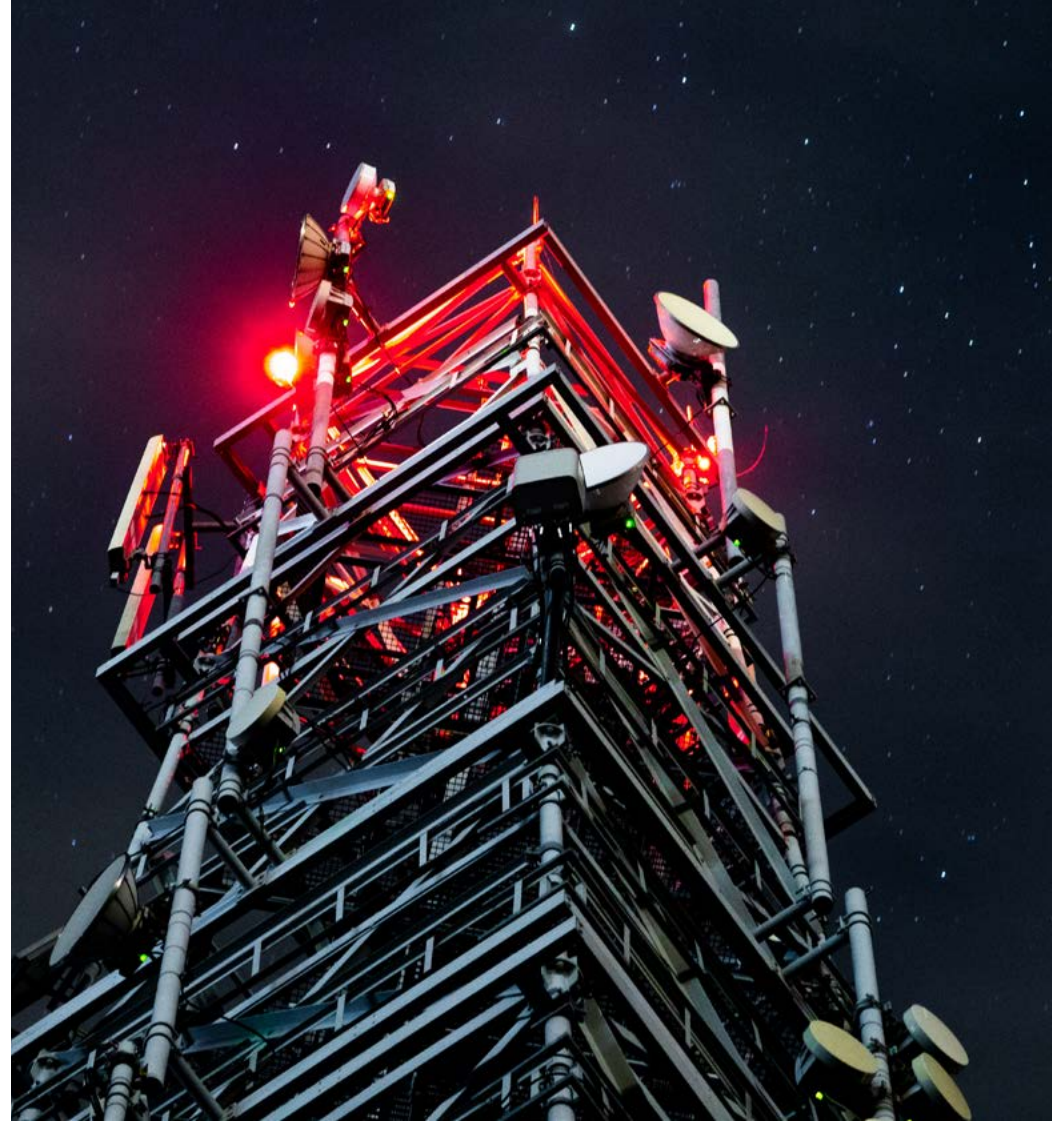

GENERAL INFORMATION

LTE – Network Architecture

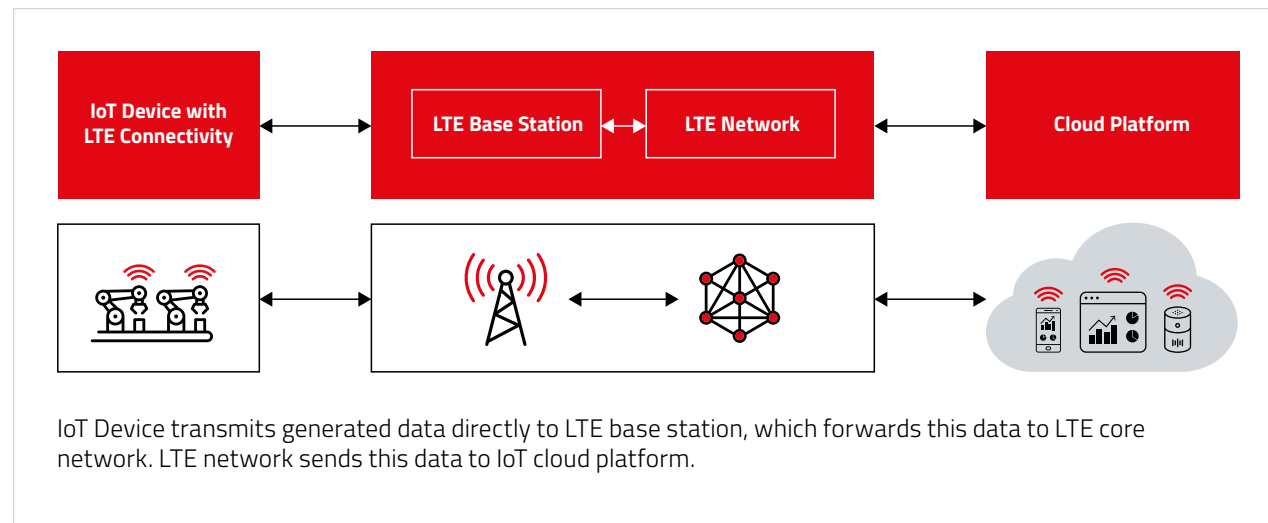

Example:

An industrial machine equipped with sensors, which collects the data on a wide range of parameters that determines its health and performance, for example, temperature, pressure, vibration frequency. This collected data is transmitted to LTE base station. LTE base station forwards this data to LTE core network. LTE network passes over this data to the cloud platform.

Advantages of Cellular Networks

- Global Coverage and Roaming:** Cellular networks are available globally, global coverage of cellular technologies makes companies to deploy their IoT devices globally. In addition, global presence of cellular networks enables roaming and mobility.
- Secure and Reliable Transmission:** Cellular technologies have default security procedures enabled. This procedure make sure only certified, subscribed and authenticated devices can access mobile network for data, SMS and voice services.
- Standardized:** 3rd Generation Partnership Project (3GPP) develops standards for cellular communication. These standards are internationally agreed standards. The device manufacturers and network service providers follow cellular communication standards.
- Network Quality of Service:** Licensed spectrum is assigned exclusively to network service providers for independent usage. In this licensed spectrum, service provider deploys his network. IoT devices have to subscribe for data or SMS services to network service provider, they are contractually bound to provide quality of service for subscribers.
- Certified Device Access:** Certified devices access the cellular network. This enables efficient utilization of licensed spectrum and minimizes the risk. Secured connectivity and strong authentication of IoT devices.

LTE-M and NB-IoT

Both LTE-M and NB-IoT are two new standards of Radio Access Technology designed for Low Power Wide Area Networks (LPWAN), which are very energy-efficient radio transmission technologies. LTE-M and NB-IoT features Low power consumption, wide coverage, massive connectivity and lower cost. LTE-M and NB-IoT enable a wide range of IoT applications where low cost, Low power consumption and good building penetration are important.

Generally, NB-IoT is suitable for applications that only need to transmit small data volumes. NB-IoT offers maximum uplink data rate 158 kbps. This data rate is adequate for transmitting the sensor generated data such as temperature, pressure, filling levels etc.

LTE-M fills the gaps where NB-IoT is no longer sufficient or where NB-IoT is not available. For example, LTE-M has a higher uplink data rate of up to 1 Mbit/s and can thus transmit a large amount of data in less time. LTE-M is suitable for asset tracking type of applications where higher data rate with mobility support is required.

Difference between LTE-M and NB-IoT

	NB-IoT	LTE-M
Bandwidth	180 KHz	1.08 MHz
Max Uplink Peak data rate	158 kbps	1 Mbps
Max Downlink Peak data rate	127 kbps	588 kbps
Power Consumption	Best for sending small data	Best for sending large messages
Voice Support (VoLTE)	No	Yes
Latency	High	Low
Mobility	No connected mobility – for stationary devices	Full mobility support – for asset tracking applications
Deployment Type	In-band LTE, LTE guard bands, Stand-alone	In-band LTE

Refers to the 3GPP release version 14.

	Firmware updates	Indoor coverage	Remote control devices	Suitability for moving devices	Possibility to grow with new use cases
LTE-M	●●●	●●●	●●●	●●●	●●●
NB-IoT	●	●●●	●●	●	●

	Low latency	Outdoor coverage	Data rate	Battery lifetime	Suitability for moving devices
LTE	●●●	●	●●●	●	●●●
LTE-M	●●	●●	●●	●●	●●
NB-IoT	●	●●●	●	●●●	●

CELLULAR MODULE



Adrastea-I

2615011136000
LTE-M / NB-IoT Cellular Module



Characteristics

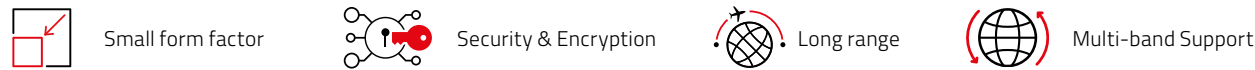

- Flexible mode selection as LTE Cat M/NB-IoT
- LTE-Cat.M supported bands: B2/B3/B4/B5/B8/B12/B20/B25/B26/B28
- NB-IoT supported bands: B3/B5/B8/B20/B28
- 3GPP Release 13 compliant, Upgradable to Release 14
- Small form factor: 13.4 x 14.6 x 1.85 mm
- Integrates GNSS (Supports GPS, GLONASS)
- Integrated user MCU exclusively for customer application development (ARM Cortex-M4, 1MB Flash, 256 KB RAM)
- Output power class 3 (23 dBm)
- Supports 3GPP TS27.005, 27.007 and Würth Elektronik enhanced AT commands
- Protocols: IPv4/IPv6, TCP/UDP, HTTP/HTTPS, TLS/DTLS, MQTT, LWM2M
- Low power consumption and longer battery life (1.57 μ A when Adrastea-I is in DHO power saving mode)
- Adrastea Commander Tool (Evaluation tool for Cellular modules)
- CE, GCF certification

Key Features

Interfaces		Protocols	
✓ USM	✓ GPIO	✓ IPV4/IPV6	✓ HTTP/HTTPS
✓ UART	✓ ADC	✓ TCP/UDP	✓ MQTT
✓ I ² C	✓ JTAG	✓ TLS/DTLS	✓ LwM2M
✓ SPI		✓ COAP	

Other Features

- Maximum Data Rate (LTE-Cat.M1):
 - Downlink: 300 Kbps
 - Uplink: 375 Kbps
- Maximum Data Rate (LTE-Cat.NB1):
 - Downlink: 127 Kbps
 - Uplink: 158 Kbps
- Firmware upgrade over USB interface
- Firmware upgrade over air

Supported Cellular Technologies

Benefits of Dual Mode:

Enable international multi-regional coverage (In some country (region) LTE-M is not available then Module will select NB-IoT and vice versa)



Integrated MCU (Exclusively for Customer Application's Firmware)

Benefits of Integrated MCU:

- ✓ Cost (External micro controller is not required)
- ✓ Size
- ✓ Power Consumption

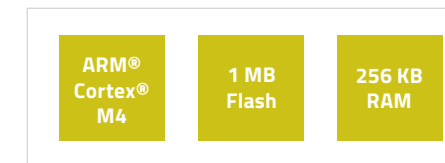

Positioning

Benefits of Integrated MCU:

Adrastea-I supports GPS and GLONASS satellite systems. This allows GNSS positioning for asset management applications where infrequent position updates are required.

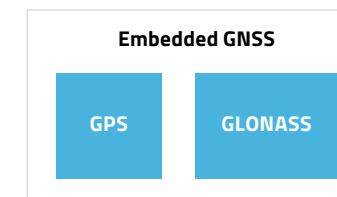

Adrastea-I:
www.we-online.com/Adrastea-I

CERTIFICATION

WE + Normal Cellular Certification Procedure

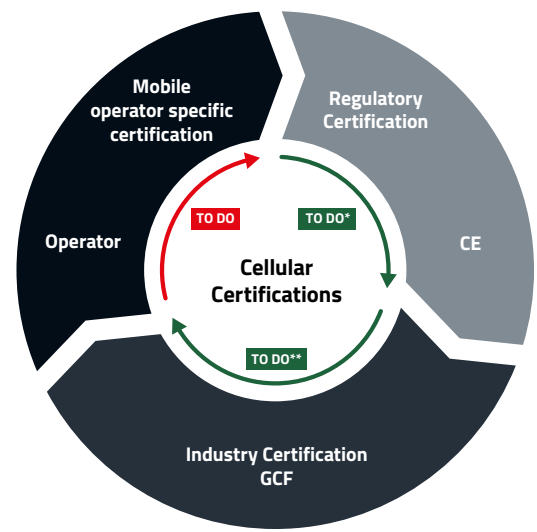

* To do on device level, Adrastea-I offers CE declaration
 ** To do on device level, Adrastea-I offers GCF certification

WE + T... Certification

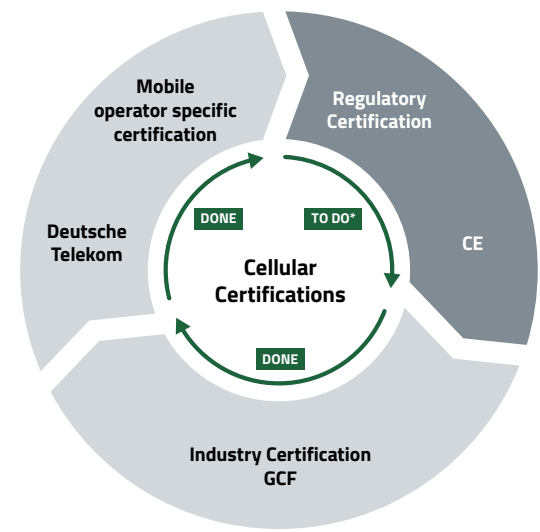

Regulatory Certification: Country specific to comply with country's regulations. Testing covers safety aspects, RF emissions do not interfere with other wireless equipment's (e.g. RF transmitter and receiver tests, EMC, electrical safety and environmental).

Industry Certification: The Global Certification Forum (GCF) is a certification organization in which manufacturers, operators and test laboratories deal with the compliance of devices in mobile networks with 3GPP standards and specifications.

Mobile operator specific certification: Testing specific to their network configuration and network parameter settings. This testing is focusing on field performance of the devices, such as radio sensitivity, data throughput.

Normal Cellular Certification Procedure



2 Types of Certification are mandatory for End Product:

1. Regulatory Certification: CE
2. Network Operator Certification: Vodafone, Deutsche Telekom etc.

End Product with Cellular Module

WE - Deutsche Telekom Certification



Certification is mandatory for End Product:

1. Regulatory Certification: CE



End Product with WE-DTAG Certified Module

Benefits of WE - Deutsche Telekom Certified Module

Be smart and ensure that your product does not require certification again.

Obtain assurance – Pre-certified module reduces final test effort.

Save time and money – the end product does not require to go through complex cellular certification process again

DTAG Coverage: Europe

Country	Operator	LTE-M	NB-IoT
Germany	Deutsche Telekom	✓	✓
	Vodafone	✓	✓
	Telefónica	✓	✓
France	Orange	✓	
	SFR		✓
Netherlands	T-Mobile Netherlands	✓	✓
	KPN	✓	
	Vodafone Libertel	✓	✓
Belgium	Orange	✓	✓
	Proximus	✓	✓
Austria	Magenta Telekom	✓	✓
	A1 Telekom	✓	✓
Slovenia	A1 Slovenija		✓
Bulgaria	A1 Bulgaria		✓
Luxembourg	Post Luxembourg	✓	
Switzerland	Swisscom	✓	✓
Czech Republic	T-Mobile Czech		✓
Slovakia	Slovak Telekom		✓
Poland	T-Mobile Poland		✓
Italy	Vodafone		✓
	TIM		✓
United Kingdom	Vodafone		✓
UK (Jersey)	JT (Jersey) Limited	✓	
Ireland	Three (Hutchinson)	✓	✓
Denmark	Telia	✓	✓
	Telenor	✓	
Finland	DNA	✓	
	Telia	✓	✓
Norway	Telenor	✓	✓
	Telia	✓	✓
Sweden	Telia	✓	✓
	Tele2	✓	✓
Spain	Telenor	✓	✓
	Orange	✓	
Croatia	Telefónica Spain	✓	✓
	Voodafone		✓
Croatia	Hrvatski Telekom		✓
Hungary	Magyar Telekom	✓	✓
Greece	Cosmote		✓
Liechtenstein	Swisscom	✓	✓
Estonia	Telia	✓	✓
Latvia	LMT	✓	✓
Malta	Melita LTD		✓
Iceland	Siminn		✓
Romania	Orange	✓	
Portugal	Meo		✓

DTAG Coverage: Non - Europe

Country	Operator	LTE-M	NB-IoT
USA	T-Mobile US	✓	✓
	AT&T	✓	
Canada	Bell Mobility	✓	
	Rogers Communications	✓	
South Korea	KT Corporation	✓	
Japan	NTT DoCoMo	✓	
	Softbank	✓	
Mexico	At&T Mexico	✓	
Australia	Radiomóvil Dipsa	✓	
New Zealand	Telstra Corporation	✓	
Taiwan	Spark	✓	
Russia	Chunghwa Telecom	✓	✓
Russia	MTS Mobile TeleSystems		✓
China	China Mobile		✓

WE Cellular Solution

Adrastea-I:
LTE-Cat.M and NB-IoT Module

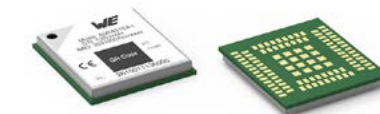

Connectivity:
IoT SIM Cards



IoT Platform:
Any public cloud

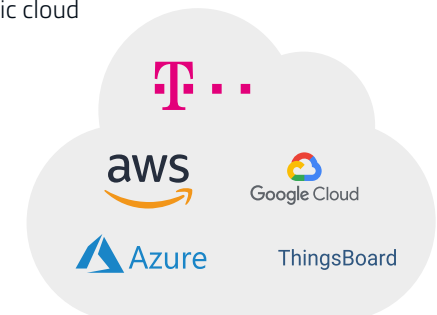

iotcreators.com/wuerth/

ADDED VALUES

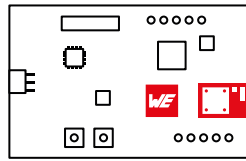

Eval Boards

- Easy testing
- Rapid prototyping
- FTDI integrated (UART to USB)
- All pins available on header
- Current measurement
- Nano SIM card holder



we-online.com/EVAL-Cellular



More information on page 16

AppNotes



Adrastea Cloud Connectivity

we-online.com/ANR032



FeatherWing

- Adafruit standard
- Easy connectable
- For complex system tests



Adrastea Commander

- Complete control of module over UART
- Evaluate GNSS functionality of module
- URL to access the WE-DTAG connectivity portal
- Approximate data consumption calculator
- Save and execute AT commands
- Run sequence of AT commands



we-online.com/Adrastea-Commander

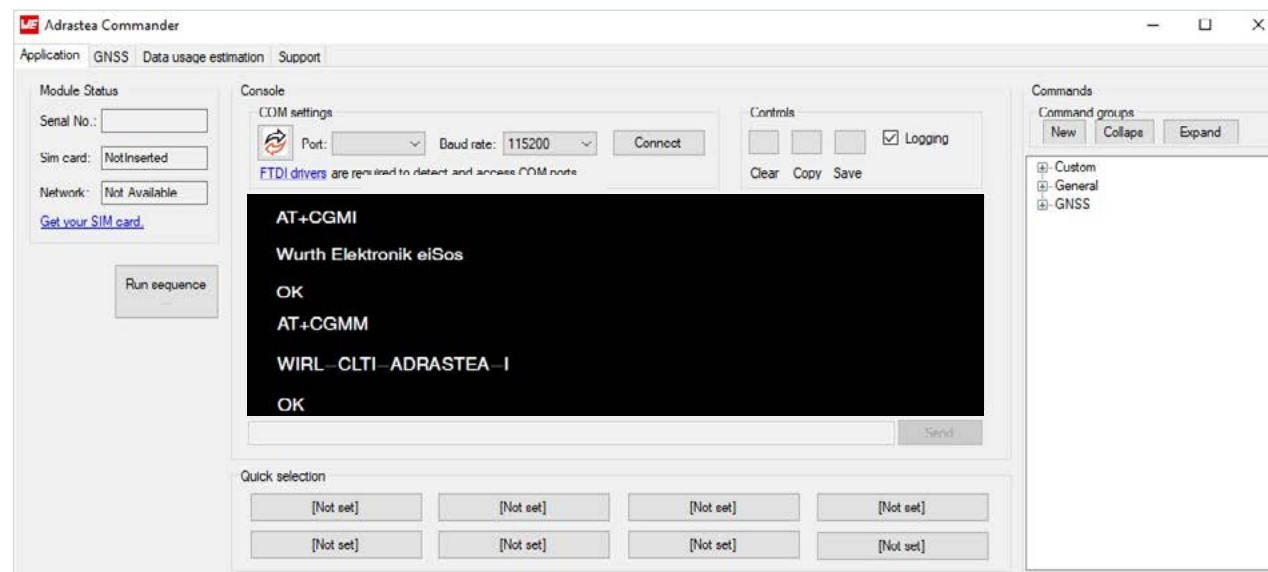

Software Development Kit

Adrastea-I cellular module has integrated ARM Cortex M4 MCU exclusive for end product applications. The MCU SDK from Sony allows software developers to write their own applications directly onto the Adrastea-I internal application MCU. SDK have several examples on how to develop your own application. These examples can be used as a reference code or as a starting point for a customer to develop his own application. Each example is a simple application that demonstrates the usage of a specific interface.

- Detailed documentation from Sony for easy Development Environment
- Reference examples
- Typically C-Language Files

we-online.com/WCO-SDK

github.com/WurthElektronik/WirelessConnectivity-SDK_STM32

WHAT HAPPENS WHEN 2G/3G IS SWITCHED OFF?

ADRASTEAI IS THERE!

BLUETOOTH®



FUNDAMENTALS

The Origin of the Name Bluetooth® – an Example of Harmonization of Different Languages

Surprisingly, the name dates back more than a millennia to King Harald “Bluetooth” Gormsson who was well known for two things: Uniting Denmark and Norway in 958 and uniting several languages. His dead tooth, which had a dark blue/grey color, earned him the nickname Bluetooth. That way, the Bluetooth-Logo was created out of the runes for H and B.

$$\begin{matrix} * & + & \text{B} & = & \text{Bluetooth} \\ \text{Nordic H} & & \text{Nordic B} & & \end{matrix}$$

As the aim of Harald was to unite countries and languages the aim of the Bluetooth® interface was to harmonise the communication between different electronic devices.

Bluetooth® – Harmonization of Interfaces

In 1996, three industry leaders, Intel, Ericsson and Nokia, met to plan the standardization of this short-range radio technology to support connectivity and collaboration between different products and industries.

The Amount of Devices is rising steadily

With the success of Bluetooth® connectivity also the number of devices is rising steadily. In 2019 about 4 billion Bluetooth® devices were shipped worldwide. The early classic standard is decreasing while Bluetooth® Low Energy, formerly known as Bluetooth® Smart, is fast-growing. Bluetooth® can be found of course in every Phone, Tablet and PC. Connected Devices, Smart Building, Smart Industry, Smart Home and Smart City are the key markets for Bluetooth® Applications.

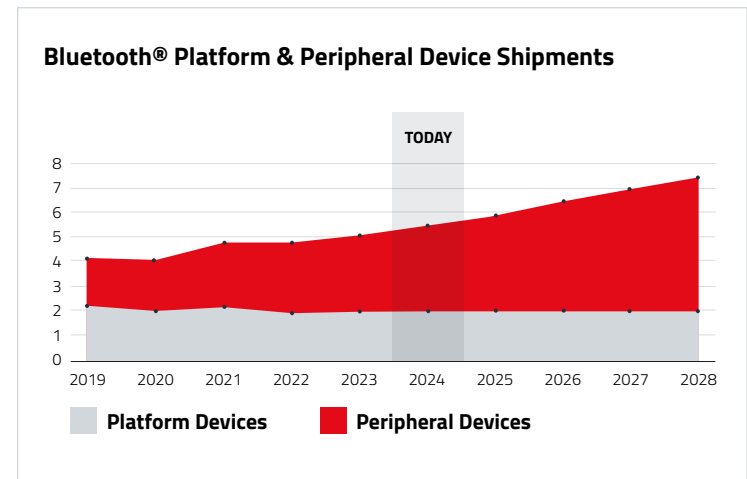

Bluetooth® as Industrial Communication Interface

Especially in the industry there is a need for easy connecting to different devices by Phone or Tablet. With no need of a display in the device itself, as the Smart Device is used for it, an immense potential of cost reduction is reachable. The flexibility of mobile apps in terms of graphical design and functionality enable an increase of user experience, which is far beyond classical displays.

Bluetooth and its three (not interoperable) standards

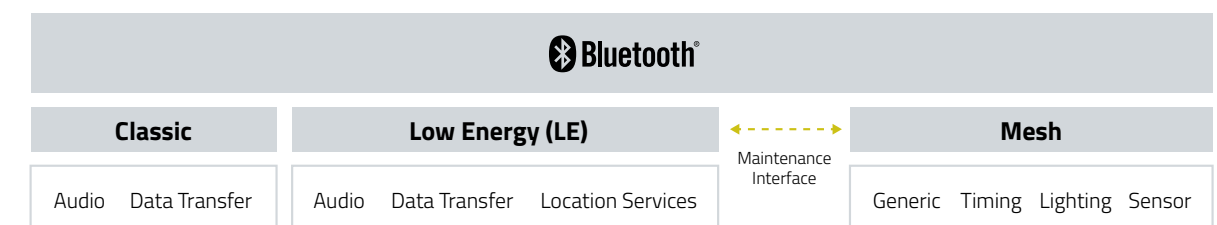

103

109

116

BLUETOOTH® STANDARDS & VERSIONS

Bluetooth® Classic

- Introduced in Bluetooth® version 1.0
- Bluetooth® Classic versions are backward compatible
- 79 channels with 1MHz bandwidth (2.402 – 2.480 GHz)
- One master, up to 7 slaves
- Time (TDMA) and frequency (FHSS) synchronization done by master
- Slave may send data only if polled by master
- Last enhanced version 3.0. with major changes



Bluetooth® Low Energy

- Defined from Bluetooth® version 4.0 onwards
- Designed for IoT and battery operated applications
- Bluetooth® LE versions are backward compatible
- 40 channels with 2 MHz bandwidth (2.402 – 2.480 GHz)
- Lower transmitting power
- Mainly short connections (to save battery lifetime)
- Different application roles and profiles: Broadcaster, Observer, Peripheral, Central

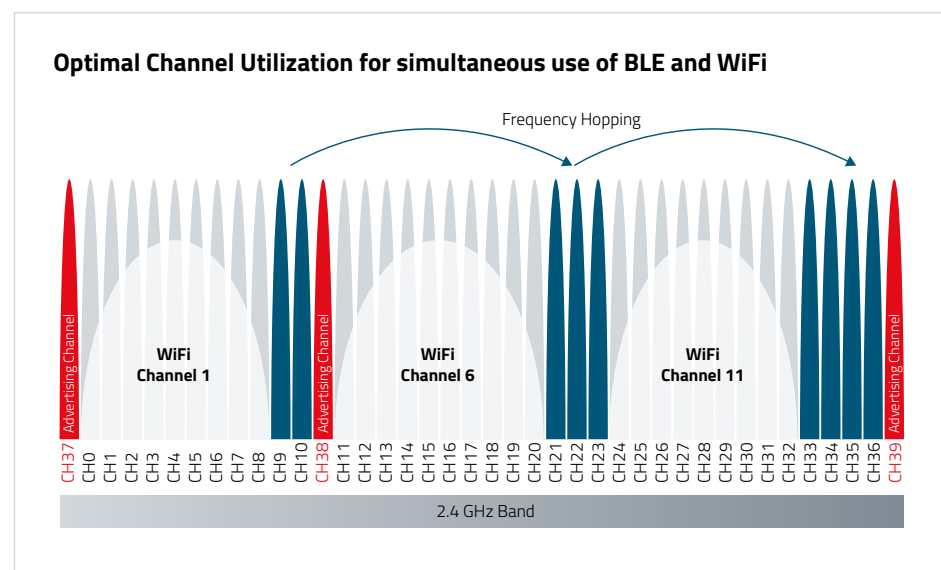
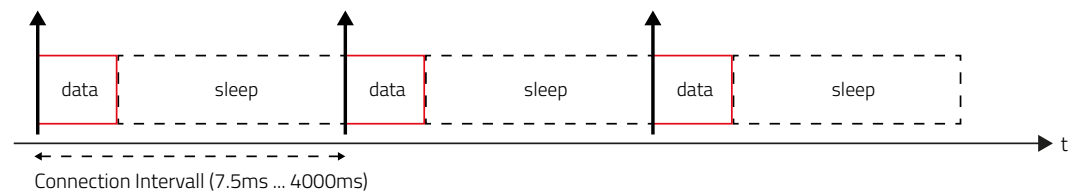

Bluetooth® Low Energy

- Generic Attribute Profile (GATT) is a generic “language” between Bluetooth® LE devices
- With the use of GATT, so called Bluetooth profiles are created, that are used for Bluetooth LE data transmission
- Custom GATT profiles: Amber SPP-like (Serial Port Profile) e.g. Bidirectional transmission of arbitrary data
- Predefined GATT profiles:
 - Battery service profile, e.g. Shares value x in percentage 0% (discharged) - 100% (fully charged)
 - Notification service when status changes
 - Link loss service: e.g. Alerts after timeout, or link is lost or user alert

History of Bluetooth®

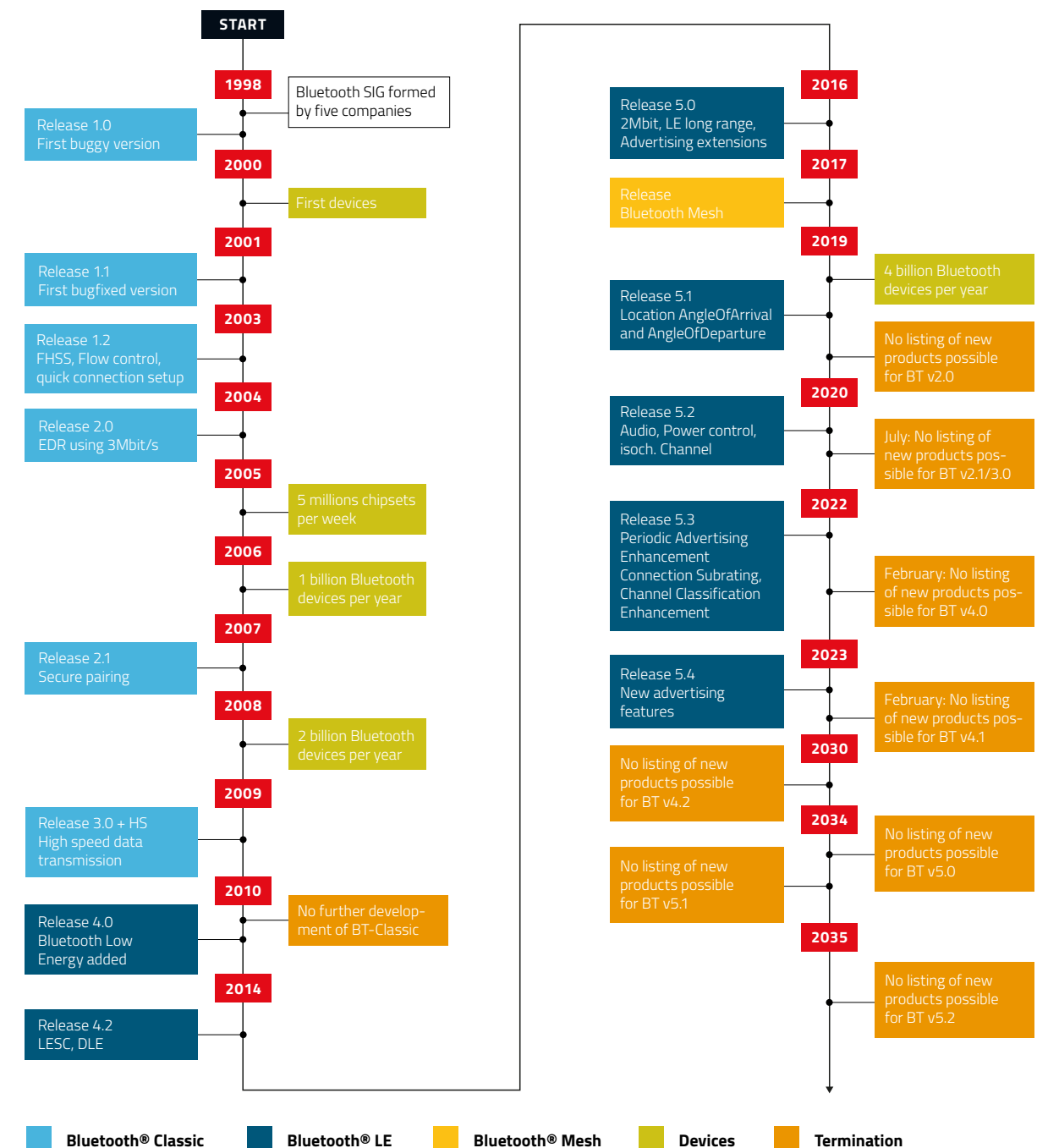

Withdrawal: Specifications withdrawn by the Bluetooth® SIG are not maintained and will no longer be available for download on the Bluetooth® public website. Members are not permitted to complete qualifications/declarations for any product using those withdrawn specifications.

BLUETOOTH® LOW ENERGY IN GENERAL

Bluetooth® LE roles – connection based

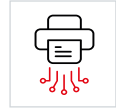

Peripheral

- Offers connections and services
- Defines the security level of its services and data
- Acts as slave
- Example:** Most applications, Door control, Service interface, Light, Roller Shutter, Heart rate monitor



Central

- Initiator for all connections with peripherals
- Always as master in a connection with a peripheral
- Example:** mobile phone at service interface, remote controller

Bluetooth® LE roles – connection less



Broadcaster

- Only transmits advertising events
- Example:** Sensor beacon



Obeserver

- Only receives advertising events
- Example:** Beacon receiver

Bluetooth® LE 4.0

- First version of Bluetooth® LE
- Low energy as protocol stack specified
- 31 Bytes per radio data packet (→ low throughput)
- Output power lower than 10 mW (10 dBm)

Bluetooth® LE 4.1

- Better coexistence with 4G radio
- Optimisation of Bluetooth® LE behaviour through configurability of parameters (time interval for reconnection)
- Central and peripheral functions in one device
- New profiles, like IPSP (Internet Protocol Support Profile) for IPv6

Bluetooth® LE 4.2

- (Optional) Data length extension (DLE) to support packets up to 255 Bytes (→ higher throughput)
- (Optional) Additional secure pairing modes (Low Energy Secure Connections - LESC)

Bluetooth® LE 5.0

- (Optional) Large advertising packets
- (Optional) New frequency hopping sequence for better coexistence
- (Optional) Increased maximum output power to 100 mW for higher range
- (Optional) 2 MBit/s phy data rate
- (Optional) Higher range due to LE Coded radio (Long Range mode)

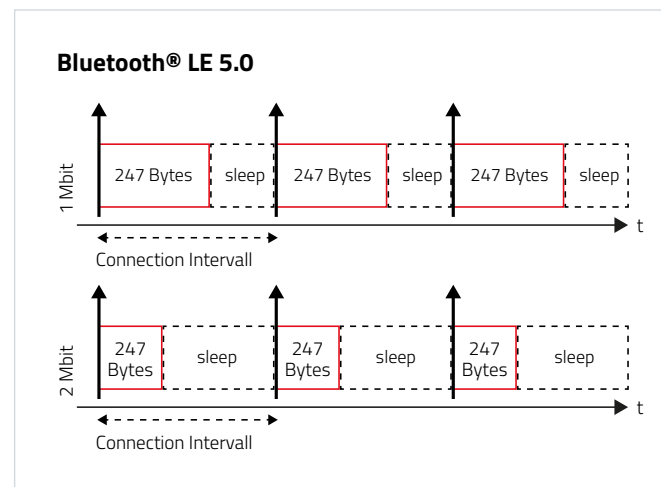

i All versions are downwards compatible.

Bluetooth® LE 5.1

- (Optional) Faster connection setup by GATT caching to save the discovery step
- (Optional) Advertising enhancements
- (Optional) Bluetooth® direction finding to detect the direction of a radio signal:
 - Angle of arrival (AoA) for item finding applications
 - Angle of departure (AoD) for indoor positioning applications

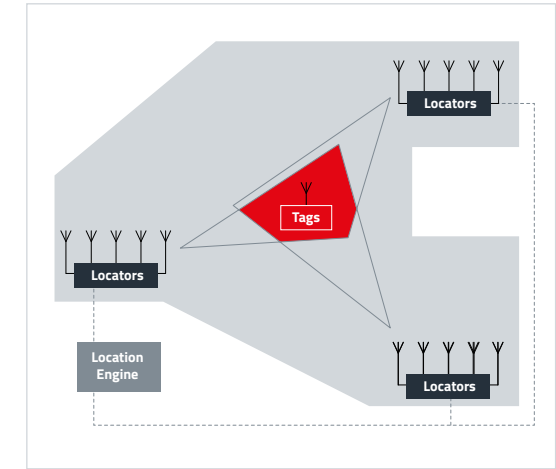

Bluetooth® LE 5.2

- (Optional) Enhanced Attribute Protocol Sharing radio sources of different profiles in one data packet
- (Optional) Adaptive power control to save power and reduce interference Monitor the RSSI and request the transmitter to reduce/increase its power
- (Optional) LE Isochronous Channels: allows the communication of time-bound data to one or more devices for time-synchronized processing discard data of radio packet after time to live (TTL)
- (Optional) New audio profiles (LE Audio)

Bluetooth® LE 5.2 Audio

- Multistream
 - Independent, synchronous streams
 - More robust and better stereo
- New applications
 - Connect hearing aid to PC, smart phone or TV
 - Broadcast audio sharing, e.g. for cinemas, theaters, airports,...
- Higher quality and less power consumption

	Original	LE Audio	Classic Audio
Codec	None	LC3 (Low Complexity Communication Codec)	SBC (Low Complexity Subband Codec)
Throughput	1.5Mbit/s	192kbit/s	345kbit/s
Energy consumption (radio)	Very High	Low	High
Audio quality	Very High	High	Medium

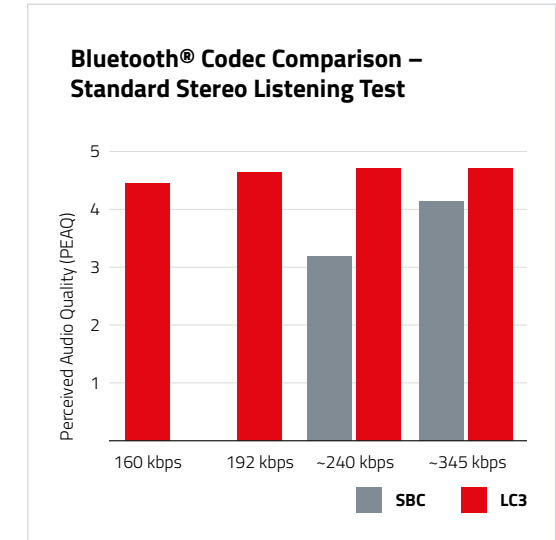

Bluetooth® LE 5.3

- (Optional) Periodic Advertising Enhancement
 - Twice detected advertising packets are dropped during reception to save current
- (Optional) Connection Subrating
 - In periods with low traffic a connection may be slowed down temporarily to save current
- (Optional) Channel Classification Enhancement
 - Now the peripheral can also provide a black list of noisy radio channels

Bluetooth® LE 5.4

- (Optional) Advertising with response
- (Optional) Encrypted advertising data for secure connectionless data transmission

BLUETOOTH® SPECIAL INTEREST GROUP (SIG)

Different Memberships

Promoter Members

Have considerable influence over both, the strategic and technological directions of Bluetooth® (Apple, Intel, IBM,...).

Associate Members

Get early access to draft specifications and are eligible to participate and gain a voting seat in working groups and committees. Furthermore, to work with other Associate and Promoter members on enhancing existing specifications.

Adopter Members

Use published Bluetooth® wireless specifications and Bluetooth trademarks.

Listing - Qualification and Declaration

- The Bluetooth® listing consists of qualification and declaration
- The qualification process is one of the most important aspects of **Bluetooth® technology, supporting interoperability** and conformity to the Bluetooth® specifications
- Bluetooth® Qualification Consultants (BQCs) are available to support members through the processes
- Qualification means the whole process including tests
- Members of the Bluetooth® SIG must complete the qualification and declaration process for their Bluetooth® enabled product to demonstrate and declare compliance
- The distributor is responsible to ensure that the required listing is performed
- A Listing is possible, if an already qualified product is used. Then there is no measuring or testing effort, only declaration and information work to be done
- BT Listing USD 11.040 per end device

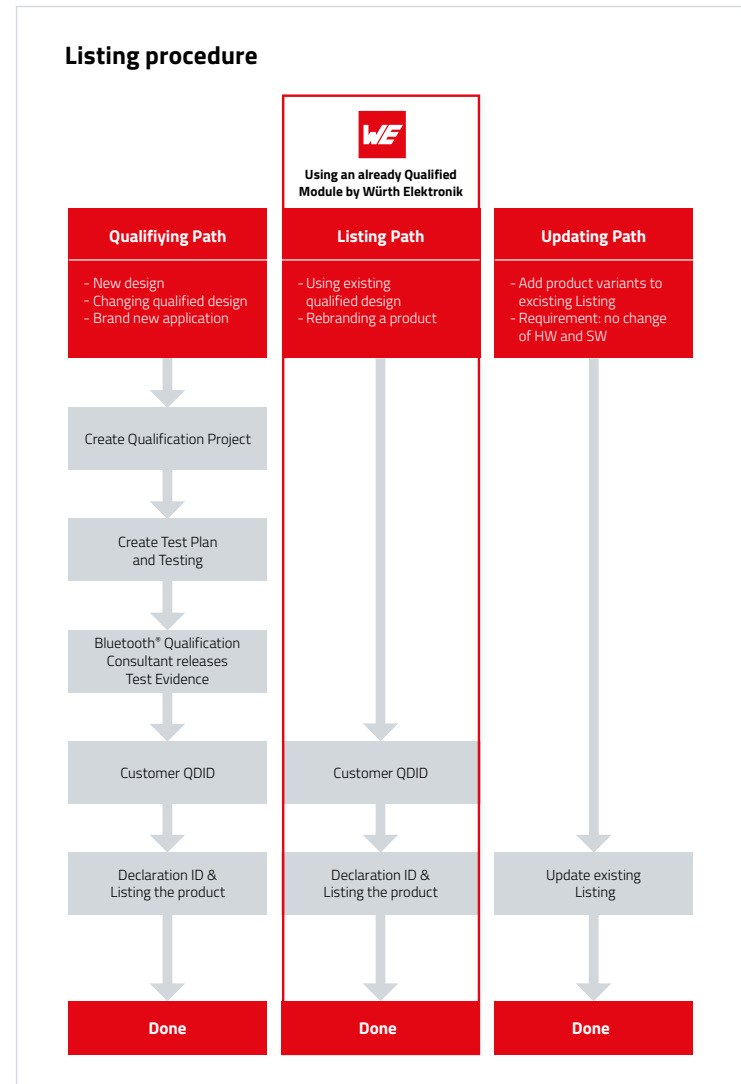

PRODUCT OVERVIEW

	BLE/WiFi Combo module			
	Proteus-e	Proteus-II	Proteus-III	Stephano-I**
Order Code (PCB Antenna)	2612011024000*	2608011024010	2611011024000*	2617011025000
Order Code (RF-Pad)		2608011124010		-
Chipset	nRF52805	nRF52832	nRF52840	ESP32-C3FH4
Bluetooth® Standard	5.1	5.0	5.1	5.0
Output power [dBm]		4	8	4.5
Power Consumption Rx [mA]	6.8	5.4	7.7	81
Power Consumption Tx [mA]	9.3	7.5	18.9	161
Power Consumption Sleep [µA]	0.3	0.4	0.4	5
Supply Voltage min - max [V]		1.8 - 3.6		3.0 - 3.6
Op. Temp [°C]			-40 ... +85	
Max Datarate [Mbps]	2	2	2	2
Payload [byte]	243	964	964	517
Measured Throughput [kbps]	100	257	343	320
Antenna (PCB, RF-Pad, SAS*)	SAS*	PCB / RF-Pad	SAS*	PCB
Long range Mode		-	✓	✓
LoS Range (Int / ext. Antenna) [m]	30 / 350	50 / 100	100 / 400	300 / -
LoS Test Conditions	2 m height, Two-ray ground-reflection, TX and RX antenna gain = 0 dB			
Interface	UART			
SPP-like Profile	✓	✓	✓	✓
USB-Radio Stick	-	✓	✓	-
FOTA	-	✓	✓	✓
Additional GPIO	2	-	6	-
Certification	CE, FCC, IC, TELEC, ETA-WPC, NCC	CE, FCC, IC, TELEC, ETA-WPC, NCC	CE, FCC, IC, TELEC, UKCA, SRRC, ETA-WPC	CE, FCC, IC, TELEC

* SmartAntennaSelection

** The values in the table correspond to the Bluetooth® values

Setebos-I Radio Module 2.4 GHz with Proprietary and Bluetooth® LE 5.1 Radio Protocol

page: 158

Proteus Connect

The most important benefit of Bluetooth® LE Connections is mostly a mobile app. With the Proteus-App we provide you a fast and easy way of testing and also a base for your own app.

- Smart-Device Mobile App for easy testing for Android and iOS
- Scan – Connect – Transmit Commands directly
- Development files available on GitHub
- Build your own App on base of Proteus-App

GitHub



we-online.com/Proteus-App

OUR SLIM-VERSION: BLUETOOTH® LOW ENERGY 5.1



Proteus-e

2612011024000
Bluetooth® Low Energy 5.1 Standard

CE FCC IC WPC



Characteristics



- Bluetooth® 5.1 qualified end product
- Miniaturized design - 7 x 9 x 2 mm
- 64 MHz Arm® Cortex®-M4 processor
- Nordic Semiconductor SoC nRF52805
- 192 kB flash memory, 24 kB RAM
- Up to 4 dBm output power
- 1 Mbit and 2 Mbit radio
- Payload size of up to 243 bytes
- Command-based and transparent UART interface
- Serial data transmission (Smart Serial Profile)
- Peripheral function
- Free definition of advertising packets
- 2 pins for remote GPIO access
- Smart antenna selection (2-in-1 Module)
- CE, FCC, IC, TELEC, ETA-WPC, NCC certification



Proteus-e:
www.we-online.com/proteus-e



Ophelia-I

Corresponding Build Your Own Firmware Module w/o flashed Firmware

page: 184

OUR FASTEST: BLUETOOTH® LOW ENERGY 5.1



Proteus-III / Proteus-III SPI

2611011024000
Bluetooth® Low Energy 5.1 Standard with
2 MBit PHY and Coded PHY (long range)

CE FCC IC WPC SRRC



Characteristics

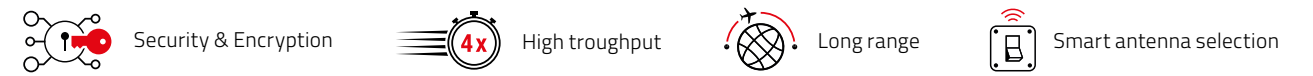

- Bluetooth® 5.1 qualified end product
- Nano SIM size - 8 x 12 x 2 mm
- ARM® Cortex®-M4 32-bit processor with FPU, 64 MHz
- Nordic Semiconductor SoC nRF52840
- 1 MB flash memory, 256 kB RAM
- Up to 8 dBm output power for higher range
- 1 Mbit and 2 Mbit radio and long range modes
- High throughput mode, 4 times higher throughput with payload size of up to 964 bytes
- Scan and Connect in long range mode
- Improved throughput with transparent UART interface (Peripheral only mode)
- Serial data transmission (Smart Serial Profile)
- LE Secure Connections (LESC)
- Connect (1:n / n:1) as central or peripheral
- 6 configurable digital GPIOs (local & remote)
- Smart antenna selection (2-in-1 Module)
- Also available as proprietary radio module (Thyone-I)
- CE, FCC, IC, TELEC, ETA-WPC, SRRC, NCC certification



Proteus-III:
www.we-online.com/proteus-III



Ophelia-III

Corresponding Build Your Own Firmware Module w/o flashed Firmware

page: 185



Webinar:

Bluetooth® LE - new adaptations



OUR ALLROUNDER BLUETOOTH® LE AND WIFI



Stephano-I New

2617011025000
Bluetooth® Low Energy 5.0 Standard
& IEEE 802.11 b/g/n 2.4 GHz Standard

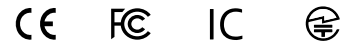

Characteristics



- Bluetooth® LE 5.0
- IEEE 802.11 b/g/n (2.4 GHz)
- Espressif chipset ESP32-C3
- UART interface available
- 4 MB Flash memory, 400 kB RAM
- Small size: 13 x 9.5 x 2 mm
- Integrated PCB Antenna
- Output power e.r.p.: 13.4 dBm (WiFi) / 4.5 dBm (BLE)
- FOTA functionality available
- Certifications: CE, FCC, IC, TELEC



Stephano-I:
www.we-online.com/Stephano-I

Comparison Development Efforts

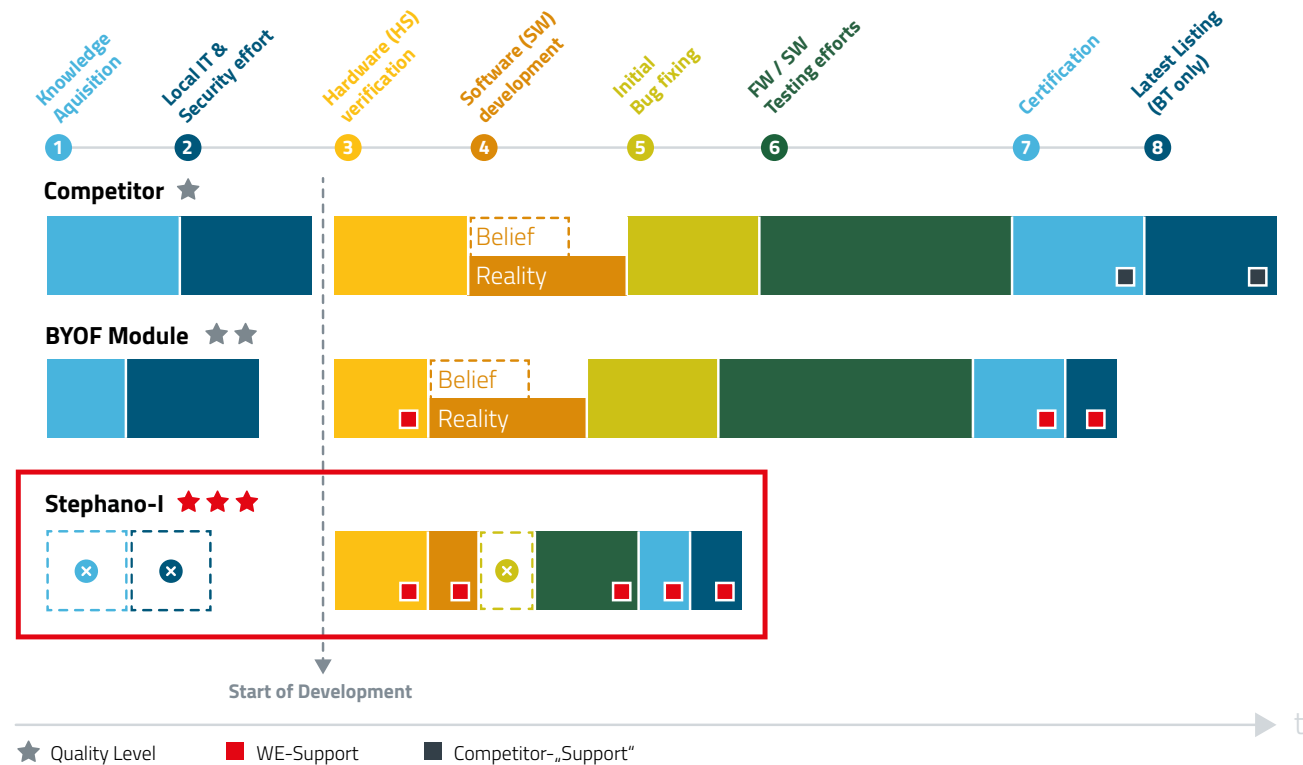

Take Away

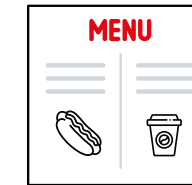

Competitors

Fast Food

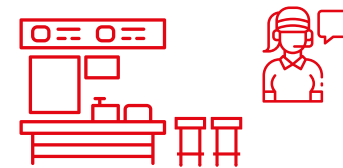

Stephano-I

Restaurant



Calypso
WiFi CERTIFIED
page: 125

Proteus-III
Bluetooth
page: 111



Orthosie-I

Corresponding Build Your Own Firmware Module w/o flashed Firmware

page: 186

BLUETOOTH® CLASSIC



Puck-I
2604021024000
Bluetooth® Classic Radio Module



Characteristics

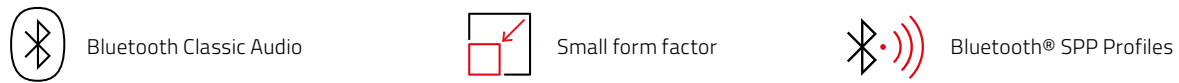

- Embedded Bluetooth® 2.0 RF module (Class 2)
- Former: BlueNicecom4 (AMB2301)
- Digital AUDIO interface (PCM interface)
- Integrated profiles: SPP, GAP, SDAP
- Supported profiles: DUN, FAX, FTP, HSP, HFP, OPP, SYNC, BIP, BPP
- Small form factor
- Integrated PCB antenna
- UART interface with programmable baud rate
- Quick-Start Evaluation Kit available
- EN 300 328 compliant

IMPORTANT NOTE

As it is not possible to add or change a listing based on the withdrawn Bluetooth® Specification 2.0 this module is not recommended for new designs.

- It is the customers responsibility to list its products with BT SIG
- Würth Elektronik still sells the products to customers, even long term

History of Bluetooth® Classic

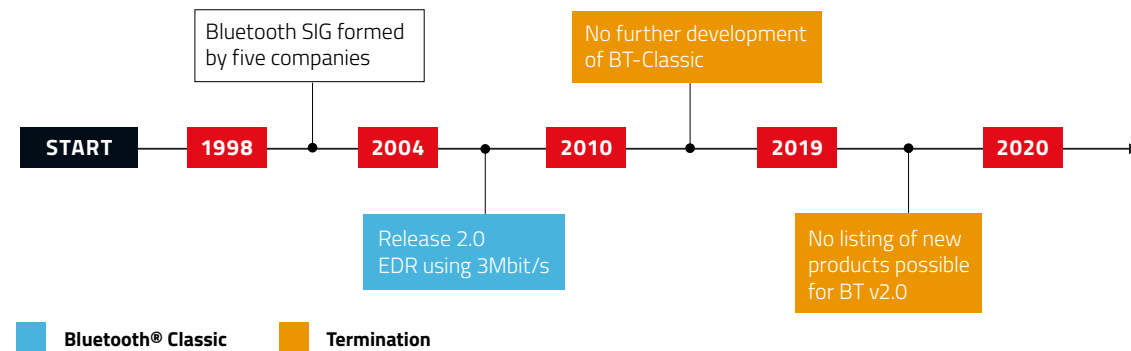

Puck-I:
www.we-online.com/Puck-I



THE FUTURE IS WIRELESS

ADDED VALUES

Development Tools

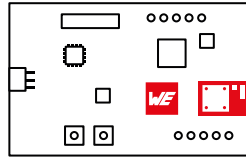

Eval Boards

- Easy testing
- Rapid prototyping
- FTDI integrated (UART to USB)
- All pins available on header
- Current measurement



we-online.com/EVAL-BLE



More information on page 16

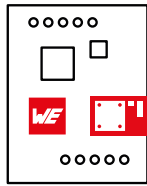

Mini Eval Boards

- Application-oriented, cost-effective and compact size
- USB connection with FTDI-cable possible (available as accessory)



we-online.com/EVAL-BLE



More information on page 16



USB-Radio Stick

- USB-FTDI-Proteus-III
- Bluetooth®-Listing included



we-online.com/USB-BLE



More information on page 16



Smart Commander

- PC-Tool for easy configuration and operation prototyping
- Automatic command creation by GUI user interaction
- Monitoring UART-Communication
- Export Commands for easy integration in the former HOST-Controller
- Test Bluetooth®-App-Connectivity easily



we-online.com/SmartCommander

AppNotes



Proteus: Low Power Application With Periodic Wake-Up

we-online.com/ANR003



Proteus: How To Use The Peripheral Only Mode

we-online.com/ANR004



Proteus: High Throughput Mode

we-online.com/ANR006



Proteus Quickstart: Connect a smart phone to a Proteus

we-online.com/ANR014



Proteus-III: Advanced Developer Guide

we-online.com/ANR009



Proteus-III: Remote GPIO control – How To

we-online.com/ANR020



Proteus-E Advanced Developer Guide

we-online.com/ANR024



Proteus-E Quickstart

we-online.com/ANR025



Bluetooth® Listing Guide

we-online.com/ANR027



nRF Connect

we-online.com/ANR030

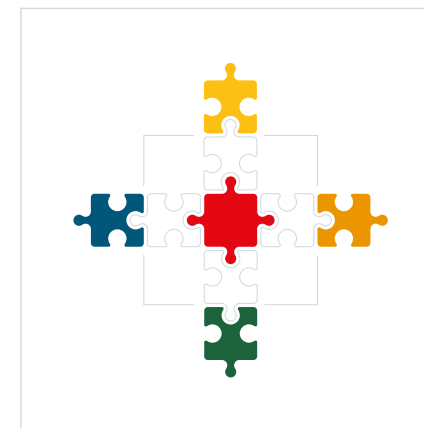

Software Development Kit

- Typically as C-Files, for mobile Apps platform specific languages
- For comfortable coding of:
 - The HOST-controller communication with the module via UART
 - PC Applications & Mobile Apps
- Code examples in Application notes and Manuals



we-online.com/WCO-SDK



github.com/WurthElektronik/WirelessConnectivity-SDK_STM32

WiFi



FUNDAMENTALS

WiFi - an Overview

Wireless LAN - WiFi

WiFi is a specification for ensuring interoperability, based on the IEEE 802.11 family of standards, which are commonly used for local area networking of devices and Internet access. WiFi is a trademark of the non-profit WiFi Alliance, which restricts the use of the term WiFi Certified to products that successfully complete interoperability certification testing.

Versions – old and new Notations (view also Table besides)

The different versions of WiFi are specified by various IEEE 802.11 protocol standards, with the different radio technologies determining radio bands, and the maximum ranges, and speeds that may be achieved. WiFi most commonly uses the 2.4 GHz and 5 GHz radio bands; these bands are subdivided into multiple channels (see figures below). Channels can be shared between networks but only one transmitter can locally transmit on a channel at any moment in time. As WiFi implements CSMA-CA/listen before talk, the probability of collisions on the same channel can be minimized.



- WiFi 1**
- 1999
 - IEEE 802.11 b
 - 2.4 GHz
 - 11 Mb/s

- WiFi 2**
- 1999
 - IEEE 802.11 a
 - 5 GHz
 - 54 Mb/s

- WiFi 3**
- 2003
 - IEEE 802.11 g
 - 2.4 GHz
 - 54 Mb/s

- WiFi 4**
- 2009
 - IEEE 802.11 n
 - 2.4 / 5 GHz
 - 150 Mb/s

- WiFi 5**
- 2013
 - IEEE 802.11 ac
 - 5 GHz
 - 3.5 Gb/s

- WiFi 6**
- 2018
 - IEEE 802.11 ax
 - 2.4 / 5 GHz
 - 9.6 Gb/s
 - WPA 3 Security

2.4 GHz Channels

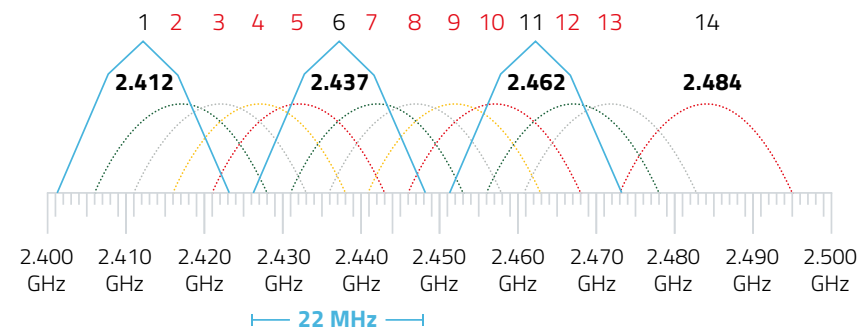

5 GHz Channels

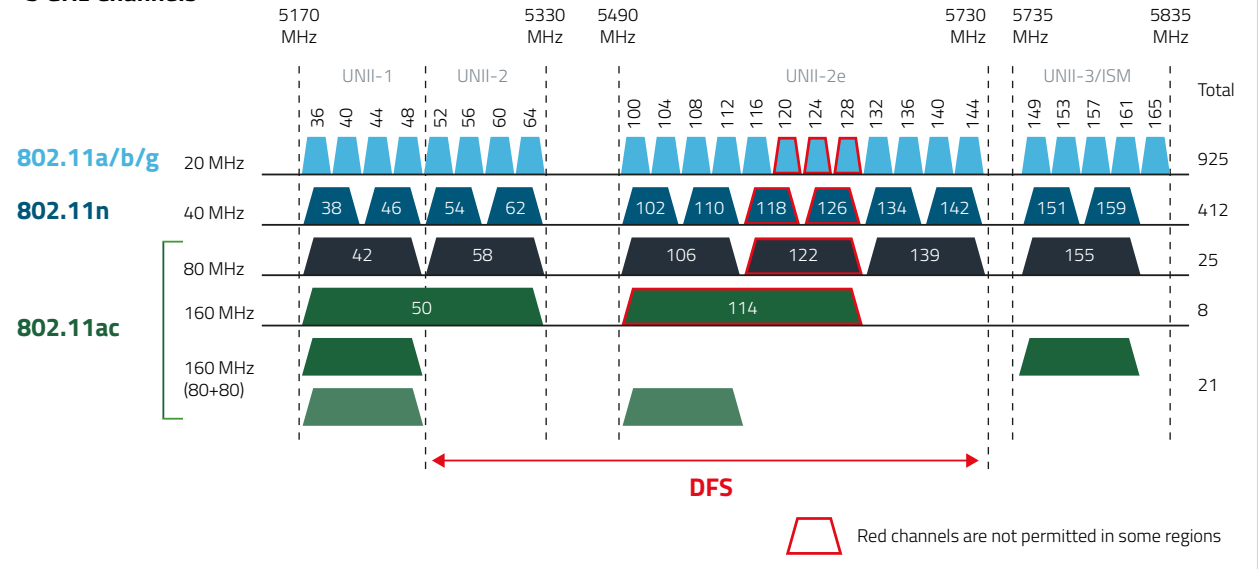

119

121

128

FUNDAMENTALS

Range and Power

WiFi's frequency bands have relatively high absorption and work best for line-of-sight use. Many common obstructions such as walls, pillars, home appliances, etc. may greatly reduce range, but this also helps minimize interference between different networks in crowded environments. An access point (or hotspot) often has a range of about 20 metres indoors while some modern access points claim up to a 150-metre range outdoors. Over time the speed and spectral efficiency of WiFi have increased. As of today: (802.11ax -> up to 11 Gbit/s), at close range, some versions of WiFi, running on suitable hardware, can achieve speeds of over 1 Gbit/s (gigabit per second).



Connection

There are two modes in which WiFi networks can operate. In the infrastructure mode, an access point acts as a central entity serving several connected clients. To connect to such a WiFi network, a user typically needs the network name (the SSID) and a password. The password is used to authenticate the client to limit access to authorized users. The most common security method is WiFi Protected Access (WPA) which is intended to protect information moving across WiFi networks and includes versions for personal and enterprise networks.

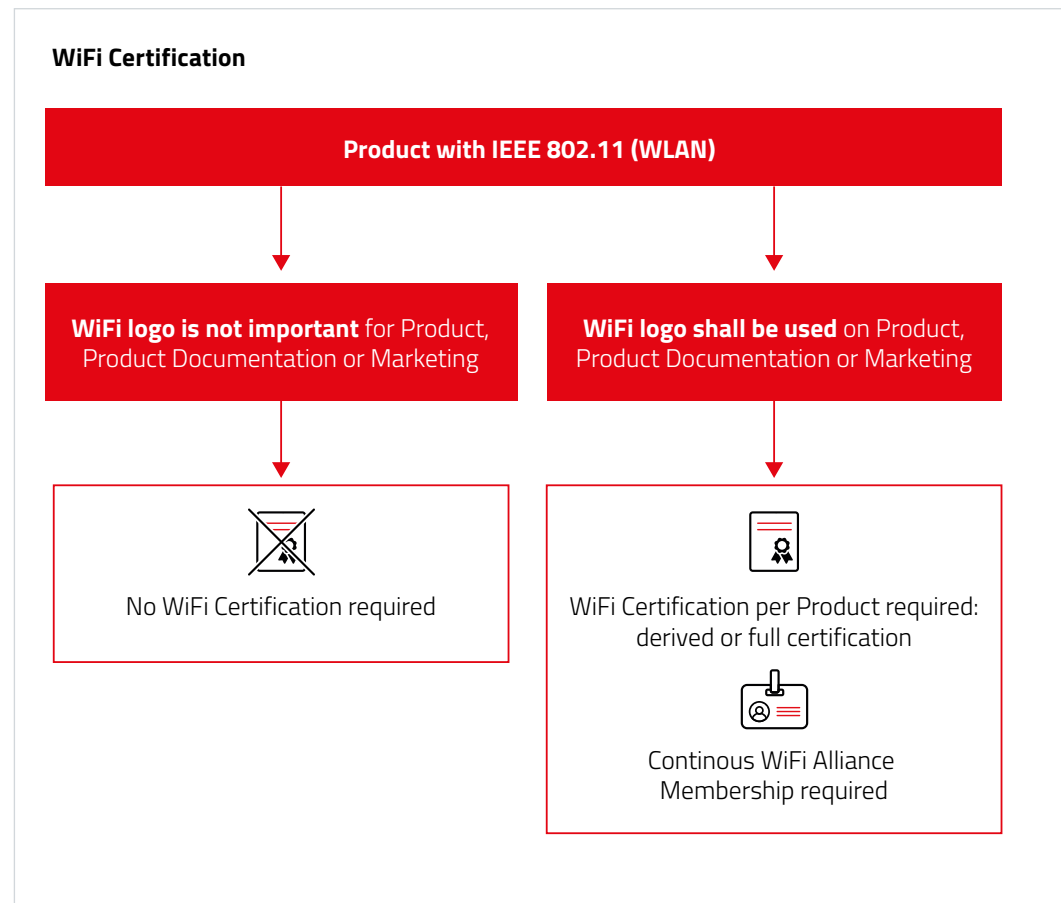
The WiFi direct mode offers a point-to-point connection without the need for a dedicated central entity. The trick with WiFi direct is – one of the two will be the central one on the peripheral entity (autonegotiated) so there is a central entity!



PRODUCT OVERVIEW

		
	Calypso-I	Stephano-I*
Order Code (PCB Antenna)	2610011025000	2617011025000
Chipset	TI - CC3220SF	ESP32-C3FH4
WiFi Standard	IEEE 802.11 b/g/n	IEEE 802.11 b/g/n
Frequency band [GHz]	2,4	2,4
Dimensions [mm]	19 x 27.5 x 4	9.5 x 13 x 2
Output Power e.r.p. [dBm]	18	13.4
Power Consumption Rx [mA]	76	82
Power Consumption Tx [mA]	230	167
Power Consumption Sleep [µA]	10	5
Supply Voltage min - max [V]	2.1 - 3.6	3.0 - 3.6
Operating Temp [°C]	-40 ... +85	
Max Datarate [Mbps]	72.2	150
Payload [byte]	1460	8192
Antenna/connection	PCB-antenna / RF-Pad (SAS*)	PCB-antenna
LoS Range (int / ext. Antenna) [m]	400	450 / -
LoS Test Conditions	2 m height, two-ray ground-reflection, TX and RX antenna gain = 0 dB	
Interface	UART	
UART baud rate	921600	115200
FOTA	Yes	Yes
GPIO's	4	2
Certification	CE, FCC, IC, TELEC	

* The values in the table correspond to the WiFi values



PRODUCTS



Stephano-I New

2617011025000
Bluetooth® Low Energy 5.0 Standard
& IEEE 802.11 b/g/n 2.4 GHz Standard



Characteristics

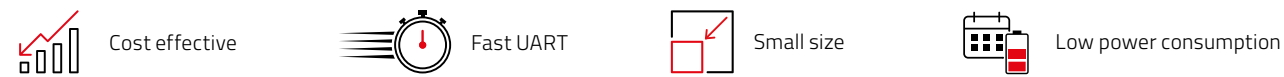

- Bluetooth® LE 5.0
- IEEE 802.11 b/g/n (2.4 GHz)
- Espressif chipset ESP32-C3
- UART interface available
- 4 MB Flash memory, 400 kB RAM
- Small size: 13 x 9.5 x 2 mm
- Integrated PCB Antenna
- Output power e.r.p.: 13.4 dBm (WiFi) / 4.5 dBm (BLE)
- FOTA functionality available
- Certifications: CE, FCC, IC, TELEC



Comparison Development Efforts

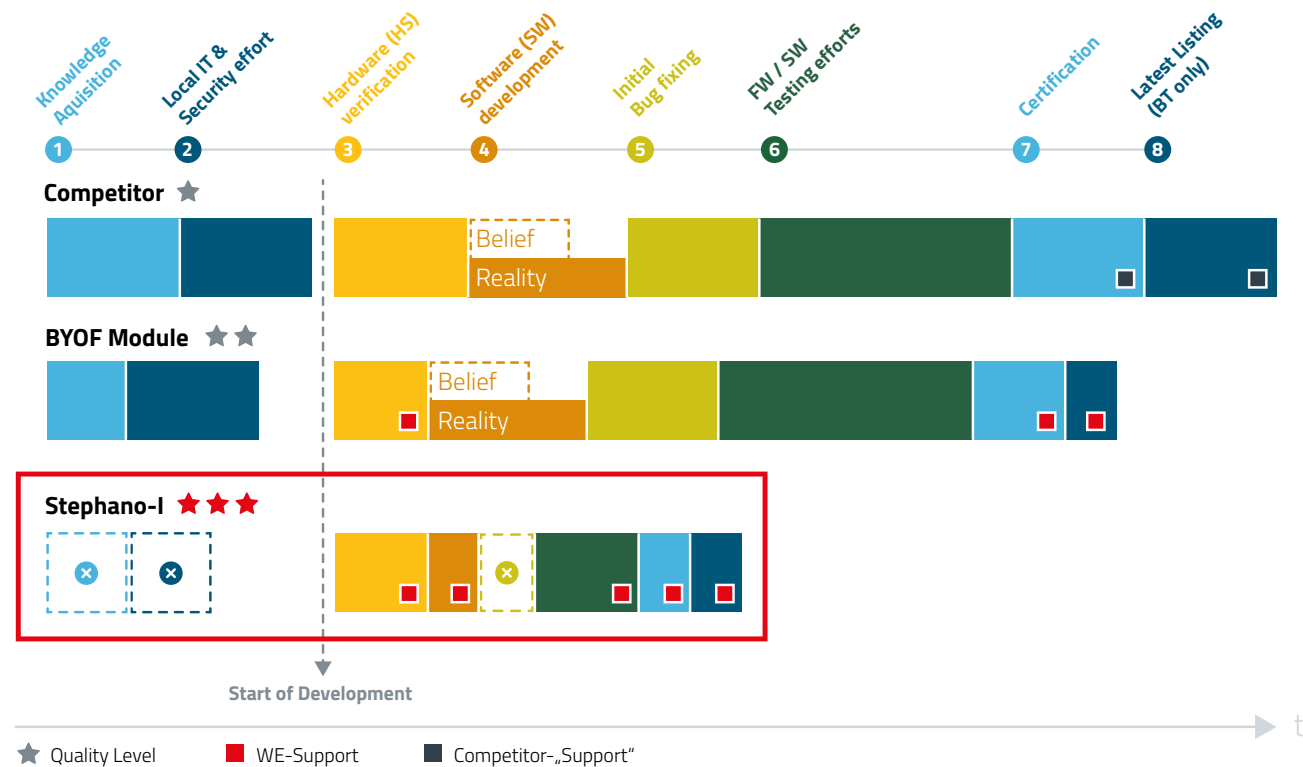

Take Away

Competitors

Fast Food

Stephano-I

Restaurant

Calypso
 page: 125

Proteus-III
 page: 111

EASY PLUG-AND-PLAY! IOT CONNECTIVITY SIMPLIFIED.

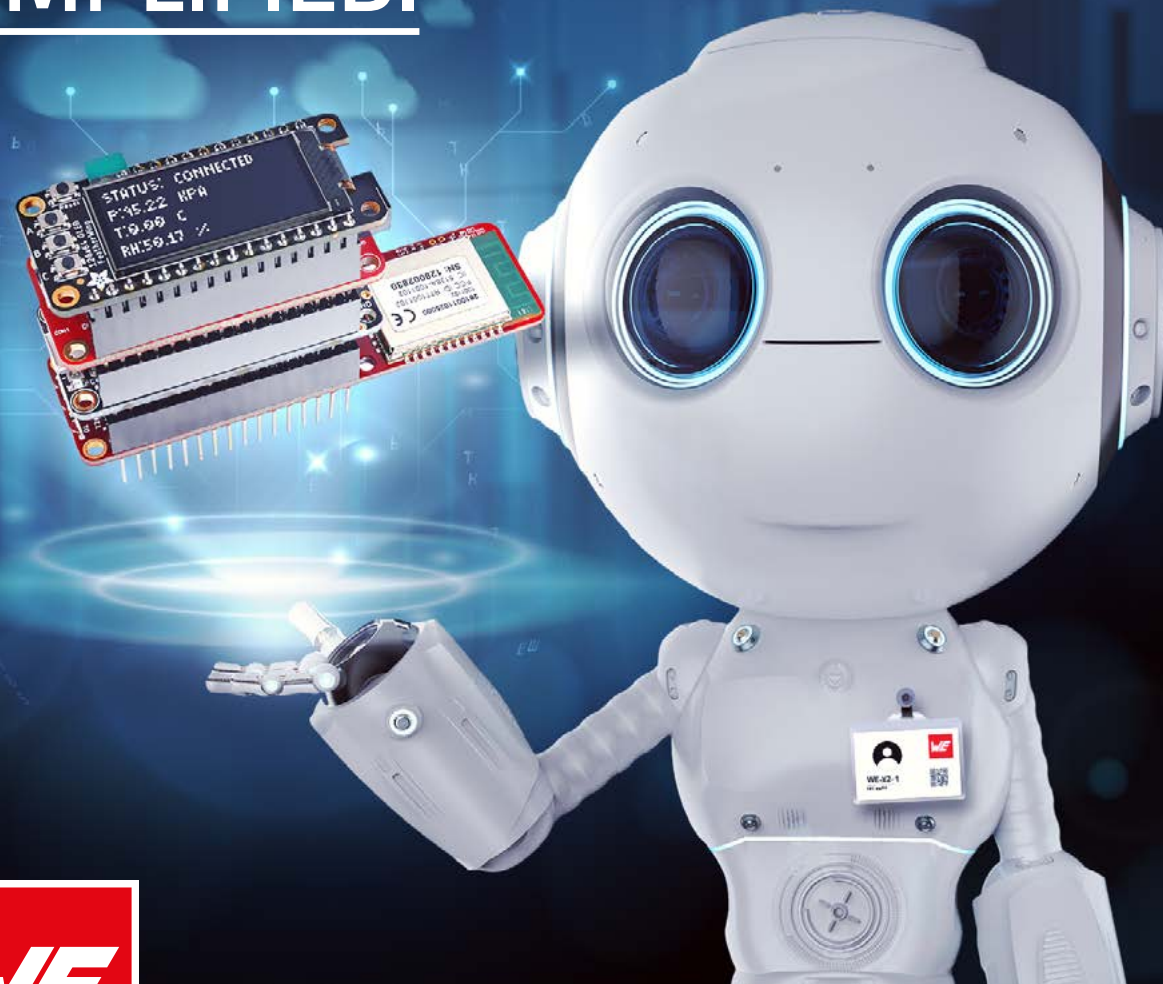

© ei50s



The Calypso IoT Design Kit is a set of stackable evaluation boards with pre-installed firmware that enables easy creation and evaluation of a secure End-to-End IoT solution using Microsoft's Azure IoT central.

The Calypso IoT Design Kit consists of the Würth Elektronik Sensor FeatherWing, the Calypso Wi-Fi FeatherWing, the Adafruit FeatherWing OLED and the Adafruit Feather MO Express.

This Design Kit provides a reliable hardware platform for easy and fast prototyping of Industrial IoT applications. It uses Adafruit FeatherWings, a series of modular open source development boards. Since this kit is „IoT Plug-and-Play“ certified, it enables seamless device-to-cloud integration in Microsoft Azure.



See complete IoT Design Kit online:
www.we-online.com/iot-designkit

OUR NETWORKER: WIFI 2.4 GHZ



Calypso

2610011025000
Fully featured standalone WiFi module
IEEE 802.11 b/g/n, 2.4 GHz



Characteristics

- Security and encryption
- Global availability 2.4 GHz licence free band
- Smart antenna selection

- WiFi module based on TI - CC3220SF wireless MCU
- Standalone WiFi operation
- IEEE 802.11 b/g/n, 2.4 GHz
- Small form factor: 19 x 27.5 x 4 mm
- Industrial temperature range: -40 °C up to +85 °C
- Low power operation to support battery operated applications
- Sleep mode <10 µA, Power save mode < 2mA (Active network connection)
- Output power +18 dBm peak (1DSSS)
- Sensitivity -92 dBm (1DSSS, 8% PER)
- Smart antenna configuration (2-in-1 Module)
- Protocols implemented: TCP/IP(IPv4/IPv6), MQTT, SNMP, mDNS, DHCP
- UART-to-WiFi bridge (Transparent mode)
- RESTful API support
- WPA3 WiFi security support
- Remote GPIO configuration and control

Product video



Calypso WiFi Radio Module
for Industrial Applications



bit.ly/WE_Calypso



Calypso:
www.we-online.com/Calypso

FEATURES

CALYPSO MODULE

1. SECURITY FEATURES

Secure Boot

- Würth Elektronik eiSos certificate stored in FLASH as standard
- Boot loader checks firmware before launching it
- Ensure it's signed by Würth Elektronik eiSos
- Prevents malware from hijacking your boot process

Security

- Good basis for secure end application:
 - WiFi security – WPA3
 - Secure boot
 - Secure storage
 - Secure socket
 - Hardware accelerated crypto engine
 - Software tamper detection
- Nevertheless and finally, the user determines end product security

Secure Storage for User Data

- Encrypted file system on FLASH
- Created on first boot-up
- Failsafe
- AT-commands to operate the file system
- Secure storage of SSL/TLS certificates, other keys and secrets
- Homepage access to upload files

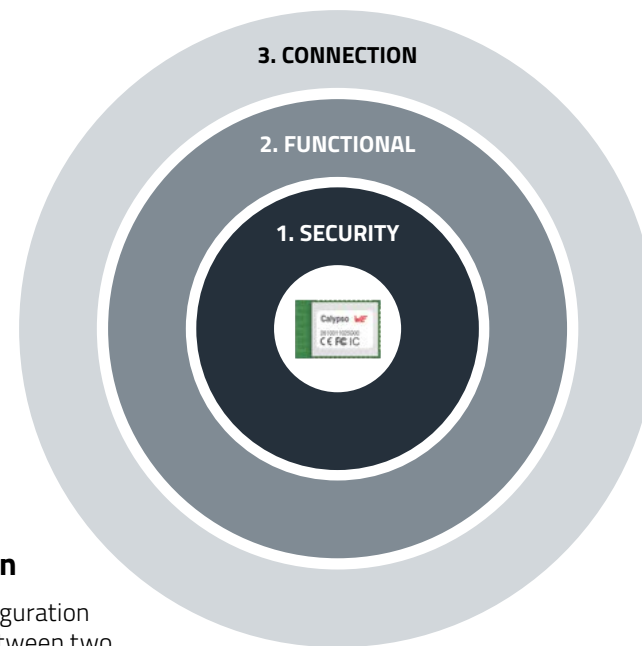

2. FUNCTIONAL FEATURES

Low Power Operation

- Power-optimized out of the box: the included firmware makes sure, that all functions are optimized to Low power consumption
- Sleep and low power modes
- Wake up:
 - Timer
 - Wake up pin
- Sleep current of only 5.5 µA
- Fast connect: from SLEEP to CONNECTED in ~350 ms

Smart Antenna Selection

Calypso's smart antenna configuration enables the user to choose between two antenna options:

On board PCB Antenna

The Calypso has an on-board PCB antenna optimized for operation in the 2.4 GHz band. A simple short between the pins RF and ANT feeds the RF output of the module to the onboard antenna. In this configuration, the module does not require any additional RF circuitry

External Antenna

For applications that use an external antenna, the Calypso provides a 50Ω RF signal on pin RF of the module. In this configuration, pin ANT of the module has to be connected to ground and pin RF to the external antenna via 50Ω feed line.

Firmware Over The Air Update (FOTA)

- Update of firmware over the wireless network
- Pin triggered: physical access security
- Signed images: malware cannot be uploaded
- Failsafe: module can always be put into factory settings

Provisioning

- Bring the device into an existing WiFi network
- In field device configuration
- Access Point mode
- Host triggered (pin/command from host)
- Web-interface – Platform independent

3. CONNECTION FEATURES

Hypertext Transfer Protocol (HTTP)

The Hypertext Transfer Protocol (HTTP) is an application layer protocol for distributed, collaborative, hyper- media information systems. It works based on a client-server mechanism where the server responds to requests from the client. HTTP running on top of a secure transport (SSL/TLS) is referred to as HTTPS.

- HTTPS server on module for provisioning and OTA
- **Customer specific webpages possible:**
 - Limited storage for http server onboard
 - Easy to change the existing page by replacing logo, device name and company name in the provided file
- HTTPS client implementation over AT commands
- All standard request methods supported (Get, Put, Post, Delete)
- Root Certificate Authorities (CA) catalog for HTTPS onboard

Multicast DNS

The mDNS protocol resolves hostnames to IP addresses in small networks that do not have a central name server. mDNS clients that needs to resolve a hostname send IP multicast query messages that asks for hosts having that name. The host then multicasts the IP address. Calypso supports mDNS and advertises the webpage by default.

Transport Layer Security (TLS) vs. Secure Sockets Layer (SSL)

Transport Layer Security (TLS), and its now-deprecated predecessor Secure Sockets Layer (SSL) are cryptographic protocols designed to provide communications security over a computer network. The TLS protocol aims primarily to provide privacy and data integrity between two or more communicating computer applications. When secured by TLS the connection has the following properties:

- The connection is private (encrypted by unique session key)
- The identity of both the communicating parties have been authenticated
- The message integrity guaranteed

Calypso supports SSL and TLS1.2

MQTT on Module

Calypso offers AT commands to create an MQTT client, subscribe to topics and publish topics.

- MQTT – Message Queuing Telemetry Transport
- Lightweight application layer protocol
- For connections with remote locations (typically M2M) where:
 - A „small code footprint“ is required or
 - The network bandwidth is limited
- Calypso implements MQTT client:
 - Offers Publish/Subscribe mechanism
 - Runs on top of TCP/TLS
- Suitable for low-power, low-bandwidth applications
- Used extensively in M2M, IoT applications

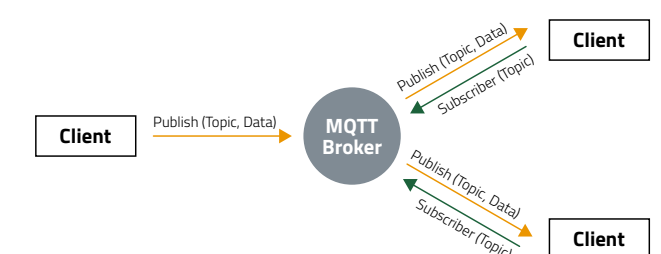

Calypso WiFi Direct (P2P)

- Peer-to-Peer without infrastructure
- Group-owner or client roles
- Auto device discovery
- Not battery optimized

ADDED VALUES

Development Tools

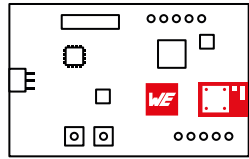

Eval Boards

- Easy testing
- Rapid prototyping
- FTDI integrated (UART to USB)
- All pins available on header
- Current measurement
- Nano sim card holder



we-online.com/EVAL-WiFi



More information on page 16



FeatherWing

- Adafruit standard
- Easy connectable
- For complex system tests



More information on page 16



AT Commander

- Complete control of module over UART
- ASCII based "Human readable" commands
- Intuitive request/response/event mechanism
- PC tool for quick prototyping "AT Commander Tool"



we-online.com/AT-Commander



Smart Commander

- PC-Tool for easy configuration and operation prototyping
- Automatic command creation by GUI user interaction
- Monitoring UART-Communication
- Export Commands for easy integration in the former HOST-Controller
- Test Bluetooth®-App-Connectivity easily



we-online.com/SmartCommander

AppNotes



Calypso IoT Application Based On Calypso Module

we-online.com/ANR007



Calypso Cloud Connectivity

we-online.com/ANR023



UART-to-WiFi bridge using Calypso

we-online.com/ANR028



Calypso Remote GPIO

we-online.com/ANR029

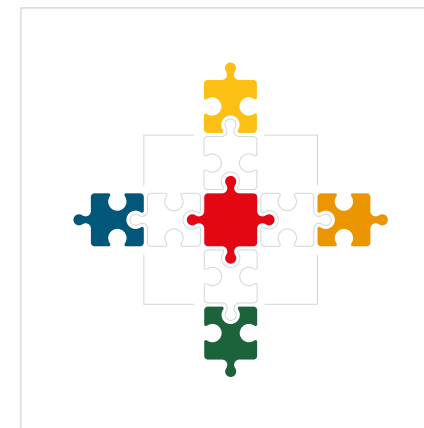

Software Development Kit

- Typically as C-Files, for mobile Apps platform specific languages
- For comfortable coding of:
 - The HOST-controller communication with the module via UART
 - PC Applications & Mobile Apps
- Code examples in Application notes and Manuals



we-online.com/WCO-SDK



github.com/WurthElektronik/WirelessConnectivity-SDK_STM32

LONG-RANGE- WAN



FUNDAMENTALS

Long-Range and Long-Range-WAN Overview

Long-Range is the physical (PHY) layer, the wireless modulation used to create the long-range communication link. LoRa® is created by Semtech. The name, LoRa®, is a reference to **long-range**.

Long-Range-WAN is an open networking protocol that delivers secure bi-directional (downlink and uplink) communication, mobility, and localization services standardized and maintained by the LoRa Alliance®.

- ✓ Long Range
- ✓ Low power consumption
- ✓ Licence free spectrum
- ✓ Indoor coverage
- ✓ Private and public deployment options
- ✓ End to End Security
- ✓ Geolocation (Network can determine the device location)



Both Long-Range and Long-Range-WAN are legally protected designations and the use of the logos is not permitted without further approval. Permission from Semtech is required for the use of the Long-Range logo. This can be applied for free of charge if a Semtech chipset is used. Long-Range-WAN is protected by the LoRa Alliance®. Use of this logo requires membership.

Membership levels (yearly costs): Institutional(\$0), Adopter (Start-Up) (\$3k), Adopter(\$6k), Contributor(\$20k), Sponsor (\$50k). Source: www.semtech.com/lora; www.lora-alliance.org.

Long-Range-WAN Overview

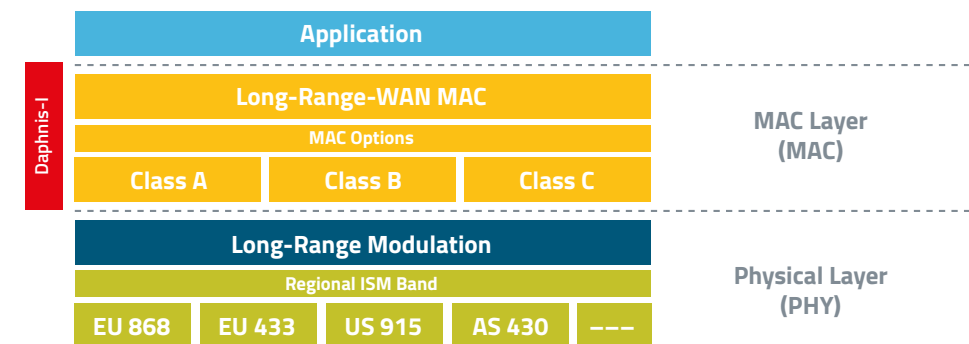

Long-Range-WAN International useable frequencies

There are different models for connecting end devices to a long-range-WAN network – private network, public network and hybrid network.

Country/Region	Frequency
EU	863 – 870 MHz (EU868), 433 – 434 MHz (EU433)
USA	902 – 928 MHz (US915)
China	470 – 510 MHz (CN470), 779 – 787 MHz (CN779)
Australia	915 – 928 MHz (AU915)
Asia/Japan	923 MHz (AS923), 920 – 923 MHz (KR920)
India	865 – 867 MHz (IN865)

131

132

136

137

GENERAL INFORMATION

Long-Range-WAN Architecture

A Long-Range-WAN-enabled end device is wirelessly connected to a long-range-WAN through radio gateways.

Uplink Transmission:

A Long-Range-WAN gateway receives messages from any end device and forwards these data messages to the Long-Range-WAN server (LNS). There is no fixed association between an end device and a specific gateway. Instead, multiple gateways can receive the same message from a single end device, the LNS performs data de-duplication and deletes all copies.

Downlink Transmission:

For downlinks communication, the Long-Range-WAN server (LNS) typically selects the gateway that received the message with the best RSSI when transmitting a downlink message. The gateway executes transmission requests coming from the LNS and forwards these data messages to end device.

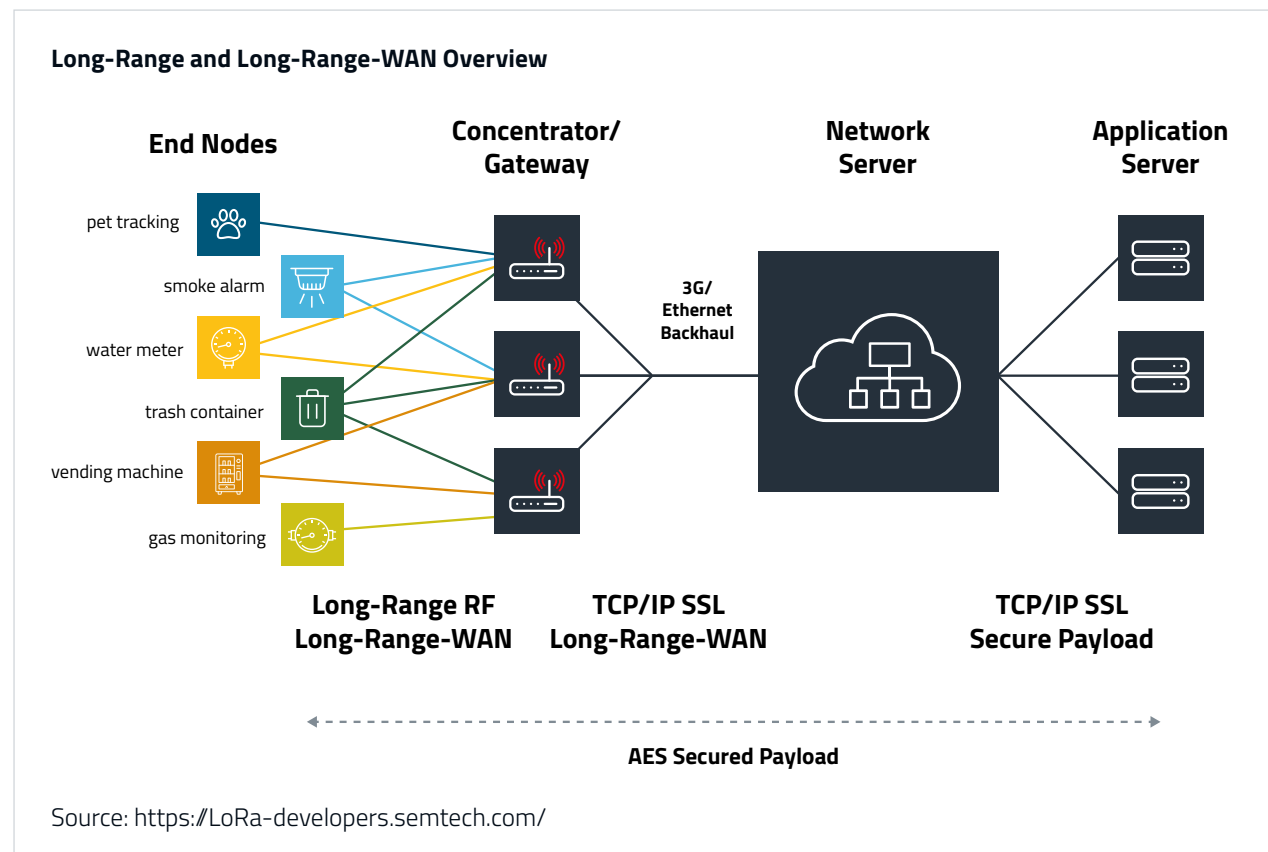

Long-Range-WAN Deployment Options

There are different models for connecting end devices to a Long-Range-WAN network – private network, public network and hybrid network.

	Deployment cost	Operational Flexibility	Mobility
Private network deployment	😊	😊	😞
Public network deployment	😞	😞	😞
Hybrid Long-Range-WAN Networks	😞	😊	😊

Comparison LowPowerWideAreaNetwork (LPWAN) Systems

	NB-IoT	LTE-M	Long-Range	mioty	PRO-WARE
	NB-IoT	LTE-M	Long-Range-WAN	MIOTY	Proprietary Tarvos-III/Thebe-II
Bandwidth	180 KHz	1.08 MHz	125 KHz	25 kHz / 100 kHz / 725 kHz	-
Max Uplink Peak data rate	158 Kbps	1 Mbps	Up to 50 Kbps	407 bit/s	400 kbps
Max Downlink Peak data rate	127 Kbps	1 Mbps	Up to 50 Kbps	407 bit/s	400 kbps
Frequency Bands	In-band LTE, LTE guard bands,	In-band LTE	EU: 868, 433MHz	868MHz as of now	868MHz
Spectrum Type	Licensed	Licensed	Un-Licensed (ISM)	Un-Licensed (ISM)	Un-Licensed (ISM)
Modulation Scheme	QPSK	16QAM	spread spectrum or FSK	(G)MSK	(G)FSK
Radio Access Technology	SC-FDMA (Uplink) OFDMA (Downlink)	SC-FDMA (Uplink) OFDMA (Downlink)	Duty-cycled limited transmissions	Duty-cycled limited transmissions	Duty-cycled limited transmissions
Subscriber and Device Authentication	Yes	Yes	Yes	Yes (shared key, AES128), cmac protected	No
Network Authentication	Yes	Yes	Optional	Yes (shared key, AES128)	No
User Data Security (Ciphering protection)	Yes	Yes	Yes	Application encryption	No
Control Data Security (Integrity protection)	Yes	Yes	Yes	Covered by network encryption	N/A
Device Certification Cost and Complexity	High	High	Low	High	Very Low
Deployment Type	Network- Operator	NetworkOperator	Private and Network Operator	Focus on private networks (base station required)	Focus on private networks
Standardization	3GPP	3GPP	Proprietary Technology Supported by LoRa-Alliance®	ETSI TS 103 357	Proprietary Technology

GENERAL INFORMATION

Long-Range-WAN Classes

The Long-Range-WAN specification defines three device types: Class A, Class B, and Class C. In a long-range-WAN network, end devices operate in one of three modes: long-range-WAN Class A, Class B, and Class C.

Class A devices ("Talk Before Listening")

In Class A devices communication is always initiated by the device. The device can send an uplink message at any time. Once the uplink transmission is completed the device opens two short downlink (receiving) windows. There is a delay (RX1 and RX2 delay) between the end of the uplink transmission and the start of the receive windows (RX1 and RX2 respectively). If the network server does not respond during these two receive windows, the next downlink will be after the next uplink Transmission.

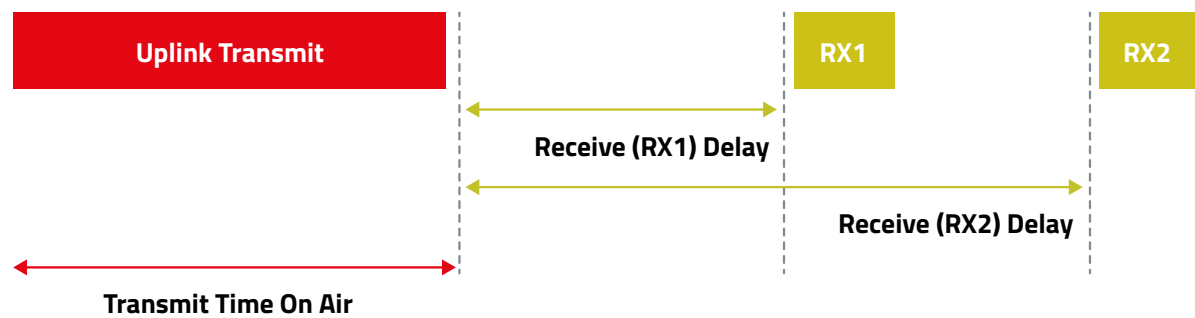

Class B devices ("Listen at Specific Times")

In addition to Class A there are periodic receive (downlink) windows that open referred to as ping slots. For the network server to be able to send downlinks when these ping slots are open the network server sends beacons through the gateway so that the module can align its clock with the network server's clock. The end-device opens a receive window (ping slots) after it receives a time-synchronized beacon from the gateway. Any of these ping slots may be used by the network server to initiate a downlink communication.

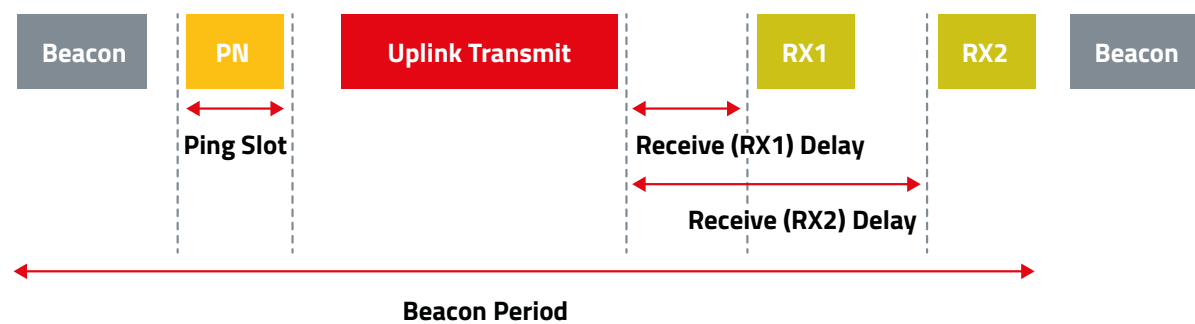

Class C devices ("Continuously Listening")

End devices operating in Class C mode have receive windows (RXC, RX1, RX2) that are almost always open. These receive windows close only when the device is transmitting. This means Class C end devices use more power to operate than Class A or Class B devices, but they offer the lowest latency for communication from the server to an end device.

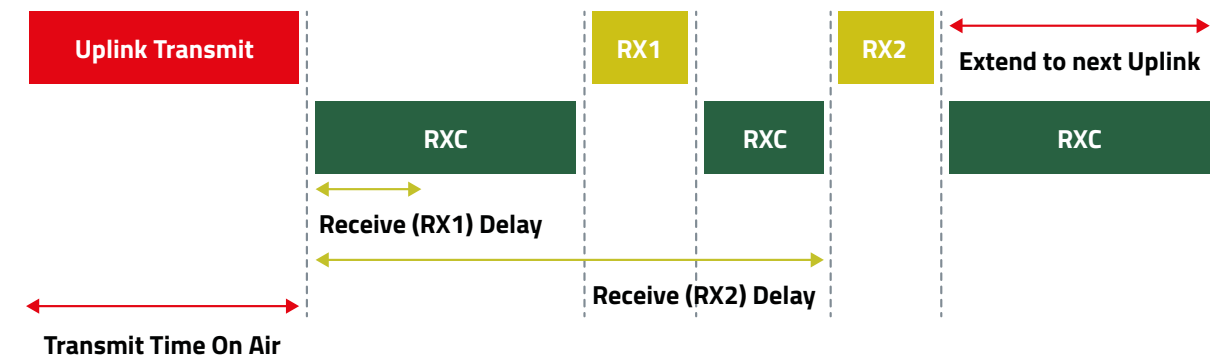

Comparison Long-Range-WAN Classes

	Description	Power Consumption	Latency	Remote control devices
Class A	"Talk Before Listening"	🔴	🟢	🔴
Class B	"Listen at Specific Times"	🟡	🟡	🟡
Class C	"Listen Continuously"	🟢	🔴	🟢

OUR LONG RANGER LONG-RANGE-WAN-MODULE



Daphnis-I
2618011181000



Characteristics

Cut&Tape: No MOQ and small packing units	Long term availability	Small Size	Low Power Consumption
--	------------------------	------------	-----------------------

- Supports long-range-WAN Specification 1.0.4
- Supports long-range-WAN Classes A, B and C
- Supported Regional Parameters: 2-1.0.1
- Supported Frequency Band EU868
- CE-conformity
- Compact Size: 15 x 16 x 3 mm
- Radio Chipset STM32WLE5CCU6
- UART Host Interface
- Maximum Output power of 14dBm
- Operating Voltage 2.0 V to 3.6 V
- Very Low Current Consumption (TX: 25mA; RX: 7mA; Sleep: 65nA)



Daphnis-I
www.we-online.com/Daphnis-I

Antenna connection

Daphnis-I's external antenna connection allows the user to choose between RF pin or UMRF connector available directly on the module.

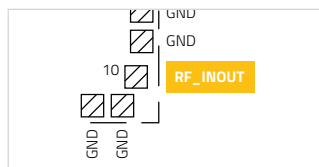

1. RF pin:

The RF pin provides a 50 Ω radio signal. This pin must be connected to the external antenna via 50 Ω feed line. If The RF pin is used, do not connect any cable or adapter to the UMRF connector on the module.



2. UMRF connector:

The ultraminiature RF connector placed on the top of the module can be used to connect an external antenna via a 50 Ω UMRF cable. If the connector is used, the RF pin shall be soldered and left electrically unconnected.

ADDED VALUES

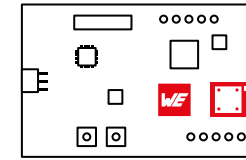

Eval Boards

- Easy testing
- Rapid prototyping
- FTDI integrated (UART to USB)
- All pins available on header
- Current measurement
- Nano SIM card holder



we-online.com/EVAL-long-range-WAN



More information on page 16



Smart Commander

- PC-Tool for easy configuration and operation prototyping
- Automatic command creation by GUI user interaction
- Monitoring UART-Communication
- Export Commands for easy integration in the former HOST-Controller
- Test Bluetooth®-App-Connectivity easily



we-online.com/SmartCommander

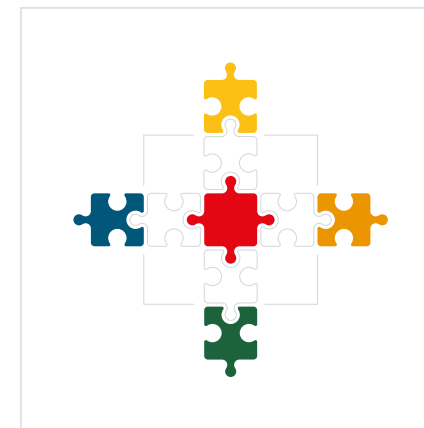

Software Development Kit

- Typically as C-Files, for mobile Apps platform specific languages
- For comfortable coding of:
 - The HOST-controller communication with the module via UART
 - PC Applications & Mobile Apps
- Code examples in Application notes and Manuals



we-online.com/WCO-SDK



github.com/WurthElektronik/WirelessConnectivity-SDK_STM32

PROPRIETARY

INDUSTRY PROVEN & LICENSE FREE



139

144

152

FUNDAMENTALS

Proprietary Radio Stack

All Wireless Connectivity RF Modules have the WE-ProWare pre-loaded

Our module added value is the WE-ProWare operating system which is fully included. Communication functions are configured with simple commands. You can easily swap between radio channels and protocols. All this makes it very easy to enter new markets with your application.

 More information on page 68

Proprietary Radio as Bluetooth® LE Alternative

- Radio communication only with authorized devices by the manufacturer
- Security aspect as argument for the end customers
- Closed communication is „invisible“ for Smart devices
- Higher throughput possible
- Saving Bluetooth® Listing costs
- Business model to build the whole chain as user experience
- Binding the end customer to the product with additional accessory with the same communication



THE IDEA to connect wireless to a device:

- Parameterization for commissioning
- Start/stop measurement
- Read out results
- Notification danger
- Connecting for service
- Checking device state for predictive maintenance
- Recalibration

NO STANDARD radio protocol is suited?

- Tried to implement Bluetooth® a few years ago:
 - Bluetooth® classic with too high energy consumption
 - Bluetooth® Listing costs too high
 - Small quantities cannot carry the high costs
 - Bluetooth® LE not flexible enough for the idea
- Same is valid for sub-GHz, LoRa®, etc.



THE SOLUTION

Proprietary Communication as solution:

- Highly flexible and easy adaption
- Fitting perfectly to the needs
- No license costs arise
- Full control over application

FUNDAMENTALS

Radio Frequency Spectrum

The radio frequency spectrum is regulated by designated regulatory authorities that define how specific spectrum bands can be used. The ISM (Industrial, Scientific and Medical) and SRD (Short Range Device) bands are free to use without license costs. As there is no single worldwide regulation, national authorities define which of the frequency bands are open for access in each specific country.

Furthermore in this license free bands there is no requirement for a specific radio protocol. That means, it doesn't matter if a proprietary radio protocol or standard radio protocols will be chosen. Everybody can use individual firmware within the regulations of the frequency bands (output power, duty cycle, ...). The correlation between data rate, range and battery life can be optimized for the application.

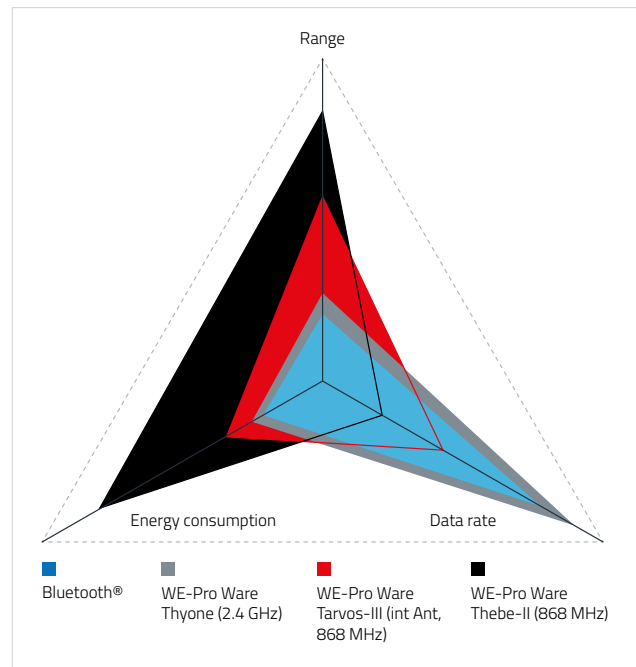

Advantages

- ✓ Security due to closed system
- ✓ More scope for design
- ✓ No umbrella organization
- ✓ More flexibility compared to standard
- ✓ No dependencies
- ✓ No license fees

Short Range Device (SRD)

Short Range Devices (SRD) are radio devices that offer a low risk of interference with other radio services, usually because their transmitted power, and hence their range, is low., typically few hundred meters. SRD often benefit from a relaxed regulatory regime compared with other radio communication equipment. The use is licence free in general. However the radio regulations have to be considered, as the Radio Equipment Directive in Europe.

Frequency [MHz]	TX Power [dBm]	TX Power [mW]	Duty cycle	max. occupied BW* [kHz]	Notes
169.400 - 169.475	+ 27	500	≤ 1 %	50	For metering devices: 10 % DC
169.400 - 169.4875	+ 10	10	≤ 0.1 %	whole band	
169.4875 - 169.5875	+ 10	10	≤ 0,001 %	whole band	0,1 % DC during 0:00 and 6:00 local time
169.5875 - 169.8125	+ 10	10	≤ 0,1 %	whole band	
433.050 - 434.790	+ 10	10	10 %	whole band	
433.050 - 434.790	0	1	no limits	whole band	-13 dBm / 10kHz PSD when bw > 250 kHz, audio/video applications are excluded
434.040 - 434.790	+ 10	10	no limits	25	audio/video applications are excluded
863.0 - 865.0	+ 14	25	≤ 0.1 % or PSA**	whole band	OBW restrictions except audio & video limited to 300 kHz
865.0 - 868.0	+ 14	25	≤ 1 % or PSA**	whole band	
868.0 - 868.6	+ 14	25	≤ 1 % or PSA**	whole band	
868.7 - 869.2	+ 14	25	≤ 0.1 % or PSA**	whole band	
869.4 - 869.65	+ 27	500	≤ 10 % or PSA**	whole band	
869.7 - 870.0	+ 7	5		whole band	audio / video applications are excluded
869.7 - 870.0	+ 14	25	≤ 1 % or PSA**	whole band	analogue audio / video are excluded
2400.0 - 2483.5	+ 10	10	no limits	whole band	non specific short range devices
2400.0 - 2483.5	+ 14	25	no limits	whole band	radio determination devices (radar, RFID,...)
2446.0 - 2454.0		500 / 4000		whole band	RFID only

* BW = Band width

** PSA = Polite Spectrum Access, allows up to 100s sending per 1 hour observation time, so a duty cycle of up to 2.77%

NETWORK TOPOLOGIES

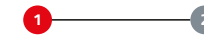

Point to point

Point to point topology is the type of network topology which is used to connect to network nodes directly with each other through a static link. In between these two nodes, the data is transmitted using this link.

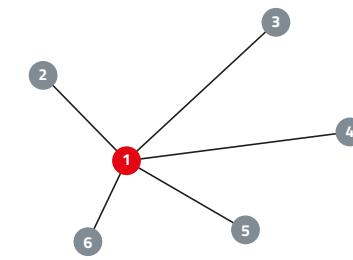

Star

In a star topology all nodes are connected via a central station. The central station can organize the nodes.

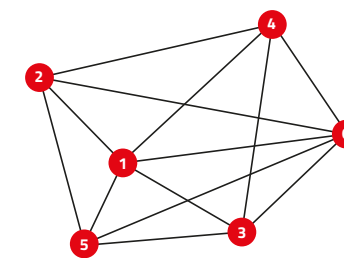

Peer to Peer

In peer to peer topology every node has a direct connection to the other nodes and can communicate to each other.

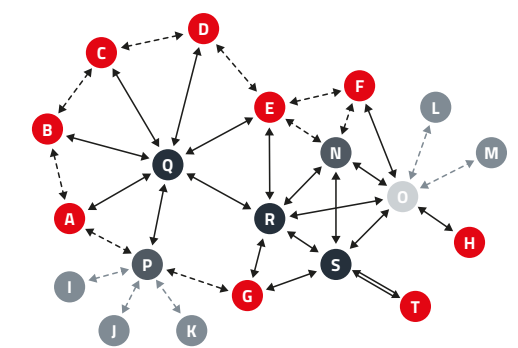

Flooding Mesh

In a flooding mesh topology an indirect communication between nodes is possible. The message will be distributed through the network until it reaches the receiver.

PROPRIETARY RADIO STACK FUNDAMENTALS & EXPLANATION



WE-ProWare is an Operating System to run the Würth Elektronik radio modules.

WE-ProWare is a software product marketed under the Würth Elektronik brand and protected by Würth Elektronik.

WE-ProWare is a manufacturer specific, non-public and not free available radio protocol. Following it is no open source software. The software's binary image and sourcecode will not be published.

WE-ProWare is a firmware for Würth Elektronik radio modules which combines user configurable radio parameters, channel access and a communication protocol which are referred to as proprietary. Thus, it does not comply with generally accepted communication standards, i.e. Bluetooth, WiFi, Ethernet or others.

WE-ProWare is a manufacturer-specific wireless transmission technology. It defines the technical aspects on how to transmit and receive data wirelessly between Würth Elektronik radio modules. Proprietary systems are closed systems that enable communication between each other. Following, the software code of WE-ProWare is specifically designed for Würth Elektronik hardware and is neither compatible nor interoperable with hardware from other manufacturers.

The WE-ProWare Radio Stack is an Industry Proven Robust Wireless Connection

With more than 25 years of experience, Würth Elektronik eiSos offers a radio stack ready to run, build and connect out of the box – called WE-ProWare. This radio stack is an easy-to-use and effective networking protocol. Without a radio stack an RF module is pure hardware. Even when Software Development Kits (SDKs) are offered, you have to spend months, sometimes years, to get your module up and running.

Extensive Features

The WE-ProWare offers you the option to connect external peripherals using numerous interfaces, such as UART or digital and analog I/O. In TRANSPARENT MODE the WE-ProWare radio stack can carry any kind of application data, simple conversion of UART to radio and vice versa. In COMMAND MODE you have full control of all features using simple commands. The UART interface is used for serial communication as well as for configuration. In this mode, the radio module acts as an easy wireless bridge between nodes. The design-in time can be tightened using the Wireless Connectivity SDK that are available in C-code.

It is Pre-loaded on all Wireless Connectivity RF Modules

Our module added value is the WE-ProWare radio stack which is fully included. Communication functions are configured with simple commands. You can easily swap between radio channels and protocols. All this makes it very easy to enter new markets with your application.

The WE-ProWare Radio Stack Supports Different Network Topologies, incl.

- ✓ Point to Point
- ✓ Point to Multipoint
- ✓ Peer to Peer
- ✓ Mesh
- ✓ Multi-hop

MORE THAN A RADIO STACK - IT IS AN OPERATING SYSTEM

NO LICENSE FEES

The license fees applicable to be able to run WE-ProWare on Würth Elektronik radio modules is always included in the hardware price, unless otherwise specified. A key difference to generally accepted standards, i.e. Bluetooth, WiFi or else is that, there are no annual membership fees, one-time costs for the device listing or recurring monthly subscription costs.













AREA OF APPLICATION

As an area of application, WE-ProWare as a proprietary radio system is always suitable if the transmitters exchange data with each other and no standardized interface to a public network through mobile phone, tablet and/or notebook is required.

WIRELESS APPLICATIONS

In conclusion, WE-ProWare does perfectly fit in wireless applications when the design of the end devices (e.g. automation machine, control cabinet) and/or the remote control(s) are under full control of the system designer. Using WE-ProWare in this case will save (recurring) license fees and offers a higher degree of flexibility in terms of data throughput, maximum transmission range and energy consumption.

PRODUCT OVERVIEW

	Module	Order Code	Freq. / MHz	Output Power	LoS Range	LoS Test Conditions Antenna height/Datarate	Antenna	Datarate PHY/ RF-Profiles	RF-Channels	RF-Architecture	Power Consumption Rx	Power Consumption Tx	Power Consumption Sleep	Supply Voltage min-max	Communication Modes	Dimensions	Foot-print	Chip-set	Certification	EVAL-Kit	USB-Radio Stick
Titania		2607011111000	169 MHz	15 dBm / 31.6 mW	3 km	2 m / 1.2 kbps	RF-Pad	1.2 kbps (0) 2.4 kbps (1) 9.6 kbps (2) 25 kbps (4)	5	P2P, star	28 mA	59 mA	10 µA	2 - 3.6 VDC	transparent, command	17 x 27 x 3.8 mm	WE-FP-1	MSP430 + TI-CC1120	CE	✓	✓
		2605031141000	433 MHz	10 dBm / 10 mW	1 km	2 m / 4.8 kbps	RF-Pad	4.8 kbps (0)	21	P2P, star	24 mA	38 mA	0.3 µA	2.2 - 3.6 VDC	transparent, command	17 x 27 x 3.6 mm	WE-FP-1	MSP430 + TI-CC1101	CE	✓	
Tarvos-I		2605041181000	868 MHz	11 dBm / 12.5 mW	1 km	2 m / 4.8 kbps	RF-Pad	4.8 kbps (0)	11	P2P, star	24 mA	38 mA	0.3 µA	2.2 - 3.6 VDC	transparent, command	17 x 27 x 3.8 mm	WE-FP-1	MSP430 + TI-CC1101	CE	✓	✓
Tarvos-II		2607021181000	868 MHz	14 dBm / 25 mW	2 km	2 m / 2.4 kbps	RF-Pad	34.4 kbps (0) 2.40 kbps (1) 100 kbps (2)	41	P2P, star, mesh	30 mA	53 mA	3 µA	2 - 3.6 VDC	transparent, command	17 x 27 x 3.8 mm	WE-FP-1	MSP430 + TI-CC1125	CE	✓	✓
Highlight: Tarvos-III		2609011081000	868 MHz	14 dBm / 25 mW	200 m	2 m / 2.5 kbps	PCB	38.4 kbps (0) 100 kbps (2) 2.50 kbps (4) 400 kbps (5)	41	P2P, star, mesh	8 mA	26 mA	0.2 µA	2.2 - 3.8 VDC	transparent, command	17 x 27 x 3.8 mm	WE-FP-1+	TI-CC1310	CE	✓	
		2609011181000			7 km	6 m / 2.5 kbps	RF-Pad													✓	✓
Highlight: Thebe-I		2609031181000	868 MHz	27 dBm / 500 mW	15 km	6 m / 2.5 kbps	RF-Pad	38.4 kbps (0) 100 kbps (2) 2.50 kbps (4)	4	P2P, star, mesh	12 mA	500 mA	0.9 µA	2.2 - 3.7 VDC	transparent, command	17 x 27 x 3.8 mm	WE-FP-1+	TI-CC1310	CE	✓	
Telesto-I		2607021191000	915 MHz	-2 dBm / 0.6 mW	550 m	2 m / 38.4 kbps	RF-Pad	38.4 kbps (0) 2.40 kbps (1) 100 kbps (2)	51	P2P, star, mesh	30 mA	30 mA	3 µA	2 - 3.6 VDC	transparent, command	17 x 27 x 3.8 mm	WE-FP-1	MSP430 + TI-CC1125	FCC, IC	✓	✓
		2607021191010	915 MHz	15 dBm / 31 mW	700 m	2 m / 38.4 kbps	RF-Pad	38.4 kbps (0)	51	P2P, star, FHSS	30 mA	53 mA	3 µA	2 - 3.6 VDC	transparent, command	17 x 27 x 3.8 mm	WE-FP-1	MSP430 + TI-CC1125	FCC, IC	✓	✓
Telesto-III		2609011091000	915 MHz	14 dBm / 25 mW	40 m	2 m / 400 kbps	PCB	400 kbps (6)	51	P2P, star, mesh	8 mA	26 mA	0.2 µA	2.2 - 3.8 VDC	transparent, command	17 x 27 x 3.8 mm	WE-FP-1+	TI-CC1310	FCC, IC		
		2609011191000	915 MHz	14 dBm / 25 mW	800 m	2 m / 400 kbps	RF-Pad													✓	✓
Themisto-I		2609041191000	915 MHz	25 dBm / 315 mW	10.5 km	6 m / 30 kbps	RF-Pad	400 kbps (6) 240 kbps (8) 30.0 kbps (9)	51	P2P, star, mesh	12 mA	400 mA	0.9 µA	2.2 - 3.7 VDC	transparent, command	17 x 27 x 3.8 mm	WE-FP-1+	TI-CC1310	FCC, IC	✓	
Highlight: Triton		2603011021000	2400 MHz	0 dBm / 1 mW	600 m	2 m / 1.50 kbps	Chip	1.50 kbps (1) 3.00 kbps (2) 6.00 kbps (3) 12.0 kbps (4) 24.0 kbps (5) 48.0 kbps (6) 72.0 kbps (7)	20	P2P, star	10 mA	38 mA	1 µA	1.9 - 3.6 VDC	command	16 x 27.5 x 3.2 mm	WE-FP-2	STM32 + EM9209	CE, FCC, IC	✓	
		2603011121000	2400 MHz	10 dBm / 10 mW	5 km	6 m / 1.50 kbps	RF-Pad													✓	
Thalassa		2606031021000	2400 MHz	-6 dBm / 250 µW	150 m	2 m / 1.50 kbps	Chip	1.50 kbps (1) 250 kbps (default)	166	P2P, star	21 mA	25 mA	6 µA	2.7 - 3.6 VDC	transparent, command	17 x 30.8 x 3.6 mm	WE-FP-3	MSP430 + TI-CC2500	CE, FCC, IC	✓	✓
		2606031121000	2400 MHz	0 dBm / 1 mW	450 m	2 m / 1.50 kbps	RF-Pad													✓	
Highlight: Thyone-I		2611011021000	2400 MHz	4 dBm / 2.5 mW			SAS -> PCB	125 kbps (0) 500 kbps (1) 1.0 Mbps (2) 2.0 Mbps (3)	39	P2P, star, mesh	7.7 mA	18.9 mA	0.4 µA	1.8 - 3.6 VDC	transparent, command	12 x 8 x 2 mm	WE-FP-4+	nRF52840	CE, FCC, IC, TELEC	✓	✓
2400 MHz	8 dBm / 6.3 mW	750 m	2 m / 125 kbps	SAS -> RF-Pad																	

Fundamentals
Cellular
Bluetooth®
WiFi
Long-Range-WAN
Proprietary
Combined
Mesh
Wireless M-Bus
Build Your Own Firmware

OUR STRONGEST: PROPRIETARY 868 MHz



Tarvos-III
2609011081000
Long range radio module
868 MHz
CE



Thebe-II
2609031181000
Long range and high power module
868 MHz
CE

Characteristics

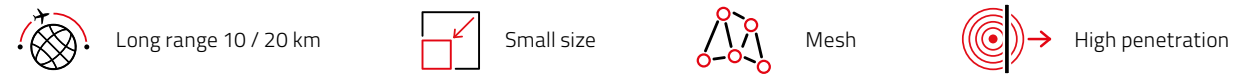

- 2 products - 1 footprint
- Footprint compatible to 915 MHz modules
- Flexibility in design
- Command mode (use all features)
- Transparent mode (uses it as a simple wireless bridge)
- Flexible addressing
- Powerful
- Interoperable Tarvos-III and Thebe-II
- Adjustable output power
- Test modes for RF measurements
- CE certification

Correlation Range - Data Rate

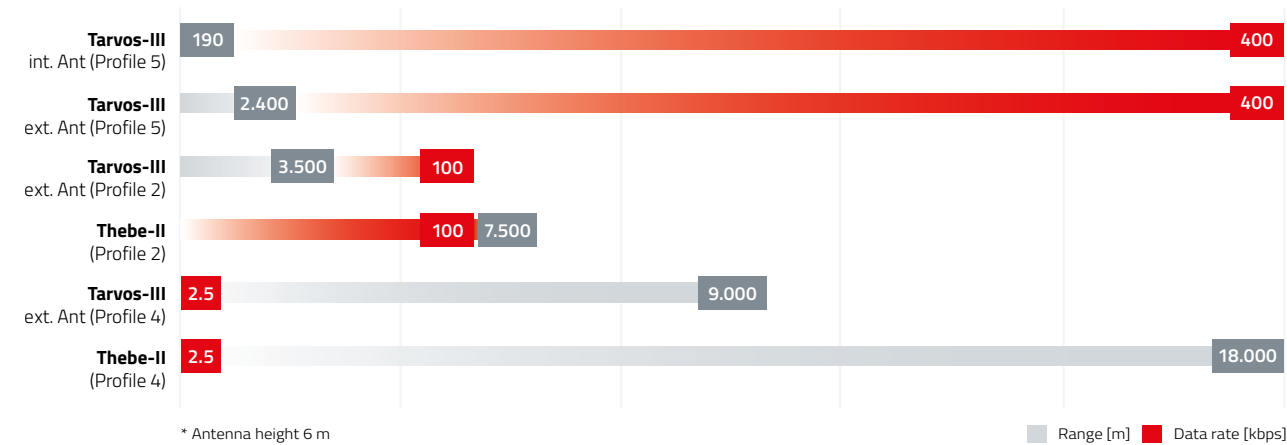

Differences

	Tarvos-III	Thebe-II
Output power	14dBm / 25 mW	27 dBm / 500 mW
Range	300 m / 10 km	15 km
RF channels	41	4
Power consumption	8 mA / 26 mA / 0,2 µA	12 mA / 500 mA / 0,9 µA
Antenna	PCB / external	external



Tarvos-III:
www.we-online.com/Tarvos-III



Thebe-II:
www.we-online.com/Thebe-II

EXCHANGEABILITY 868 MHz / 915 MHz

Compatibility Tarvos-Thebe-Telesto-Themisto Series

- Footprint compatible RF-modules
- Alternative usage by only changing the RF-module
- No change in the HW on Host-side required
- Flexible use of both frequencies for different regions possible
- 868 MHz and 915 MHz exchangeable
- Using Low or High Power modules for different ranges
- Modules with 14 dBm (25 mW): Tarvos-III and Telesto-III
- Modules with 27 dBm (500 mW): Thebe-II and Themisto-I

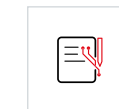
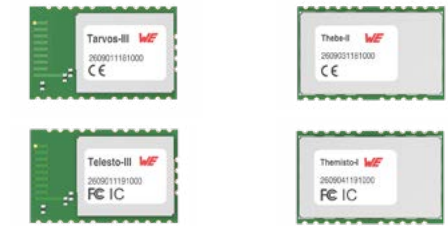

Replacing 868 MHz Radio Modules by their 915 MHz counterparts
we-online.com/ANR015

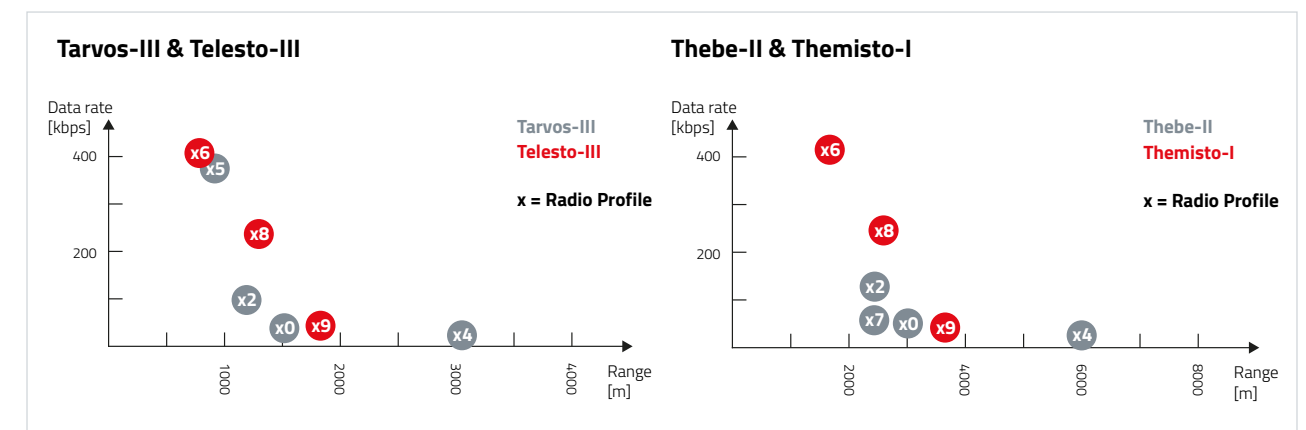

In case, the **Tarvos-III** is replaced by a **Telesto-III** radio module, the following facts have to be considered:

Feature	Information	Actions needed
Form factor & footprint	Both modules have the same form factor and footprint.	None
Pinout	Both modules are pin compatible.	None
Antenna	Both modules are available with integrated antenna and a 50 Ω antenna pad to connect an external antenna.	In case of external antenna, check whether the connected 868 MHz antenna can be also used for 915 MHz.
UART protocol	Both modules provide a command interface using the same commands and functions.	None
Radio configuration	<ul style="list-style-type: none"> The radio profile 6 of the Telesto-III is comparable in range and speed with the radio profile 5 of the Tarvos-III. In case, the Tarvos-III uses another radio profile, the range of the Telesto-III is lower, but data rate is higher, such that the data can be transmitted much faster. The channel numbering changes from 100 - 140 (868 - 870 MHz) to 200 - 252 (902 - 928 MHz). 	<ul style="list-style-type: none"> Check the range requirements of your application. Use the new channel numbers in your application code.
Certification	The 915 MHz range is regulated in North America by the FCC USA and ISED Canada.	Re-testing of the end-device is needed to determine unwanted emissions.

In case, the **Thebe-II** is replaced by a **Themisto-I** radio module, the following facts have to be considered:

Feature	Information	Actions needed
Form factor & footprint	Both modules have the same form factor and footprint.	None
Pinout	Both modules are pin compatible.	None
Antenna	Both modules are available with a 50 Ω antenna pad to connect an external antenna.	Check whether the connected 868 MHz antenna can be also used for 915 MHz.
UART protocol	Both modules provide a command interface using the same commands and functions.	None
Radio configuration	<ul style="list-style-type: none"> The radio profiles of the Themisto-I provide a faster radio transmission at the cost of range. The channel numbering changes from 129 - 132 (869.45 - 869.6 MHz) to 200 - 252 (902 - 928 MHz). 	<ul style="list-style-type: none"> Check the range and timing requirements of your application. Use the new channel numbers in your application code.
Certification	The 915 MHz range is regulated in North America by the FCC USA and ISED Canada.	Re-testing of the end-device is needed to determine unwanted emissions.

OUR SMALLEST: PROPRIETARY 2.4 GHZ



Thyone-I

2611011021000
Proprietary radio module 2.4 GHz

CE FCC IC WPC



Characteristics

- Long life battery driven application with sleep current = 0.4 μ A
- Global availability 2.4 GHz license free band
- Mesh
- Nano SIM size

- High throughput up to 400 kbit/s
- Range up to 750 m
- Control dedicated free GPIOs via remote and local access
- Easy serial cable replacement (transparent mode)
- Command mode (use all features)
- Transparent mode (uses it as a simple wireless bridge)
- Test modes for RF measurements
- Smart antenna selection (2-in-1 module)
- Encryption (AES128)
- CE, FCC, IC, TELEC, ETA-WPC certifications



Thyone-I:
www.we-online.com/Thyone-I



Triton

2603011021000
Proprietary radio module 2.4 GHz

CE FCC IC WPC

Characteristics

- Long range 5 km
- High penetration
- Global availability 2.4 GHz license free band
- Low Power Consumption

- Best-In-Class radio module & Best-In-Class RF range
- Frequency band 2.4 GHz
- Range up to 700 m line of sight / 5000 m with external antenna possible
- Small size: 17 x 30.8 x 4 mm
- Suitable for long distance applications @ low data rates
- Robust RF protocol stack
- Various data transmission modes
- Integrated software stack with extensive functions
- With integrated Chip-antenna (2603011021000) or external antenna pad (2603011121000)
- CE, FCC, IC, ETA-WPC certifications



Triton:
www.we-online.com/Triton

Comparison 2.4 GHz modules Thyone-I and Triton

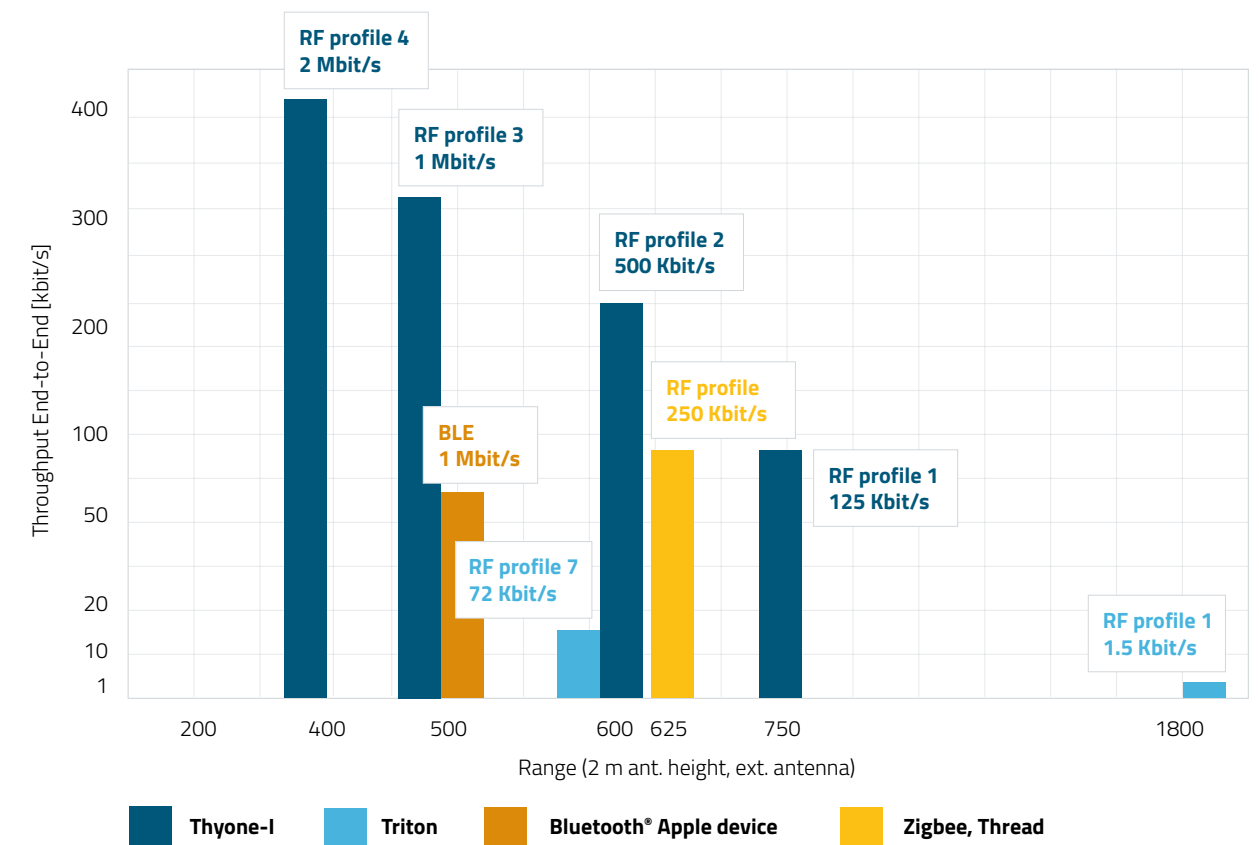

	Triton	Thyone-I
Order Code (Chip-Antenna)	2603011021000	-
Order Code (PCB Antenna)	-	2611011021000
Order Code (RF-Pad)	2603011121000	(Smart-Antenna-Selection)
Chipset	STM32 + EM9209	nRF52840
Size [mm]	17 x 31 x 3.6	8 x 12 x 2
TX power max (50 Ω) [dBm]	10	6*
TX power max (e.r.p.) [dBm]	7.5 (chip)	4 (pcb)
RX sensitivity (best range, 50 Ω) [dBm]	-115 (1.5 kbit/s)	-100 (125 kbit/s)
Range [m], 2m ant. height	1800 (@1.5 kbps) 600 (@72 kbps)	500 (@125 kbps) 350 (@1 Mbps)
Range [m], 6m ant. height	5500 (@1.5 kbps) 1900 (@72 kbps)	1500 (@125 kbps) 1000 (@1 Mbps)
Current TX (max power) [mA]	37 (10 dBm)	19 (8 dBm)
Current TX (0 dBm) [mA]	13	8
Current RX [mA]	9	8
Current Sleep [μ A]	1	0.4
Current Sleep [μ A]	2-FSK	2-GFSK
Max. End-to-End throughput [kbps]	12	400

* TX Power register set to 8 dBm resulting in 6 dBm at 50 Ω (due to nRF52 internal loss in WLCSP package)

EXCHANGEABILITY

2.4 GHZ





Exchangeability Thyone-I and Proteus-III

- Footprint compatible RF-modules
- Flexible use of both technologies possible
- Alternative usage by only changing the RF-module
- Future-proof circuit with adaptable interface
- No change in the HW on Host-side required

Take future trends into account and keep the flexibility!

Committing today on a wireless technology for tomorrow seems impossible. How nice would it be to expand your application with different radio protocols at any time without any layout changes. Würth Elektronik offers you a high degree of freedom with the radio module footprint. It is one quality proven hardware base, that prevents you from enormous costs of re-design in future already today. Choose between a Bluetooth®, Wirepas™ or proprietary radio module or the combined variant of proprietary and Bluetooth®.

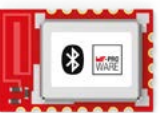
5-in-1 Footprint

Proteus-III  <small>CE FC IC WPC SRRC</small>	Thetis-I  <small>CE FC IC</small>
Thyone-I  <small>CE FC IC WPC</small>	Setebos-I  <small>CE FC IC</small>
Ophelia-III  <small>Build Your Own Firmware</small>	

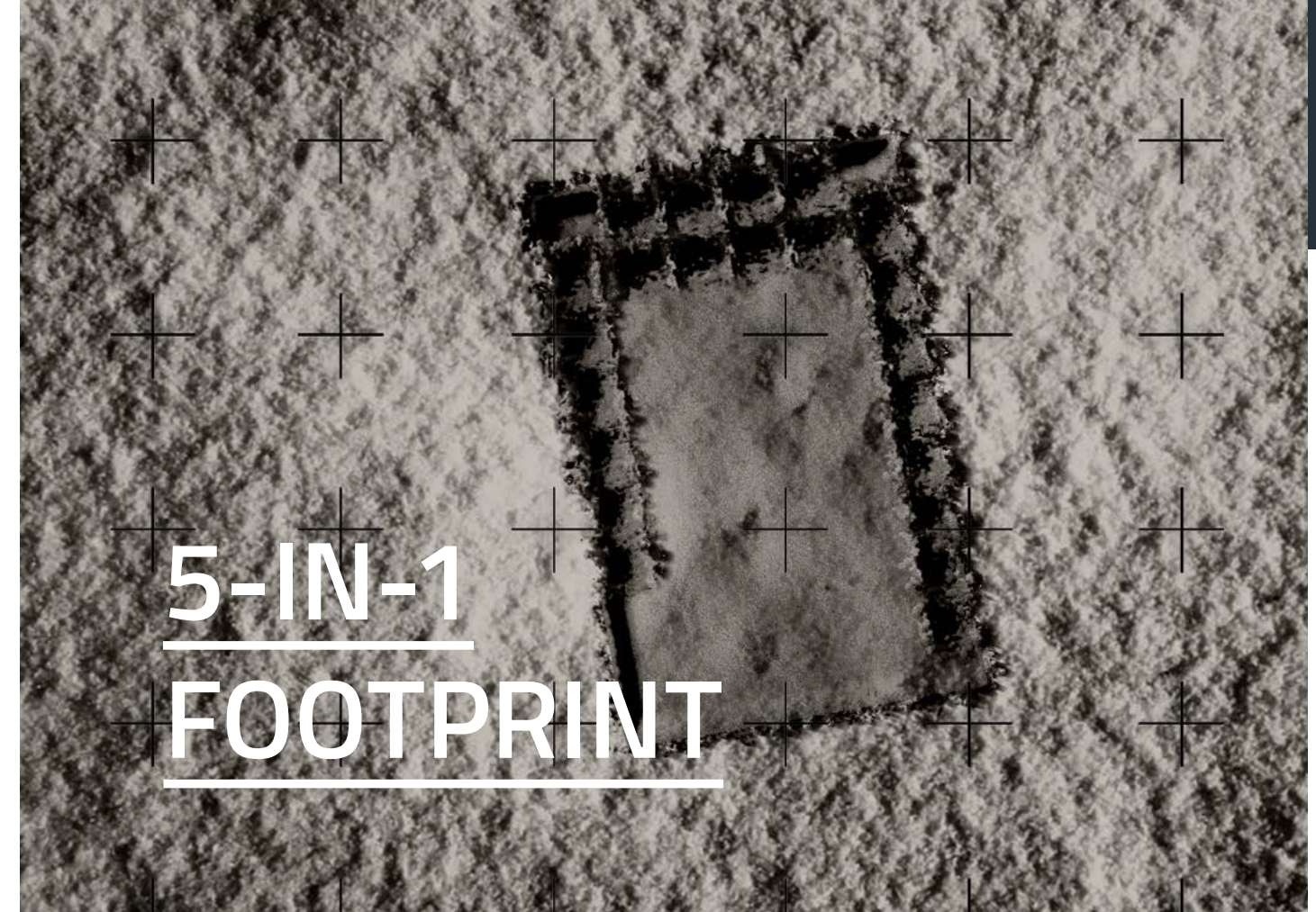

Proprietary application with Thyone-I

- For applications with enclosed communication
- Communication invisible for smart devices
- Connection to a standard device only with a certain USB-radio stick possible
- Connected sensors building up a secure network

Usecase

- Secure network set up
- Easy connection between the nodes
- Extending interfaces by connecting a USB-radio stick
- A gateway connecting securely to the network provides the combined result to the user via Bluetooth, WiFi, Cellular, MQTT or on any platform

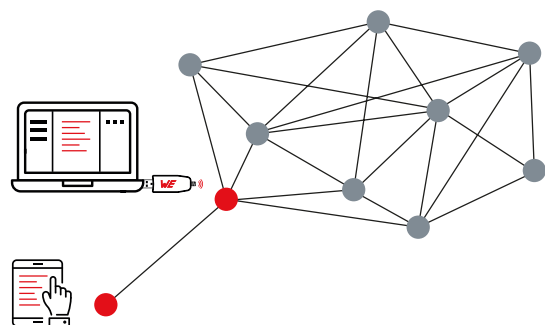

Bluetooth® application with Proteus-III

- Connecting directly to smart devices
- Parameterization of a sensor
- Reading out results from a measuring device

Usecase



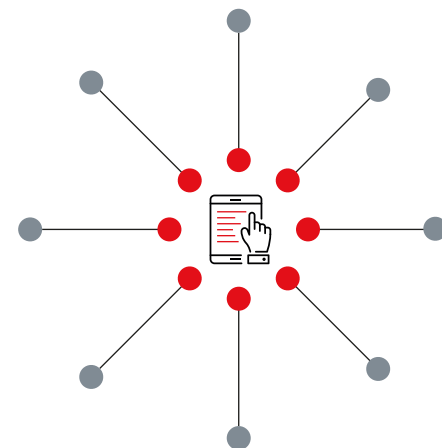

- Connecting manually to each sensor via smart device
- Easy and smart consumer-oriented



TAKE FUTURE TRENDS INTO ACCOUNT AND KEEP THE FLEXIBILITY!

Committing today on a wireless technology for tomorrow seems impossible. How nice would it be to expand your application with different radio protocols at any time without any layout changes. Würth Elektronik offers you a high degree of freedom with the radio module footprint.

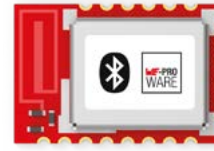
It is one quality proven hardware base, that prevents you from enormous costs of re-design in future already today. Choose between a Bluetooth®, Wirepas™ or proprietary radio module or the combined variant of proprietary and Bluetooth®.

Proteus-III	Thetis-I	Thyone-I	Setebos-I	Ophelia-III
				
<small>CE FC IC WPC SRRC</small>	<small>CE FC IC</small>	<small>CE FC IC</small>	<small>CE FC IC</small>	<small>Build Your Own Firmware</small>

ADDED VALUES

Development Tools

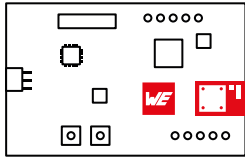

Eval Boards

- Easy testing
- Rapid prototyping
- FTDI integrated (UART to USB)
- All pins available on header
- Current measurement



we-online.com/EVAL-BLE



More information on page 16



USB-Radio Stick

- USB-FTDI-RF-Module
- Range extension in Flooding Mesh networks
- Simple radio connection for computer



we-online.com/USB-BLE



More information on page 16



Smart Commander

- PC-Tool for easy configuration and operation prototyping
- Automatic command creation by GUI user interaction
- Monitoring UART-Communication
- Export Commands for easy integration in the former HOST-Controller



we-online.com/SmartCommander

AppNotes



Wireless Connectivity Software Development Kit (SDK)

we-online.com/ANR008



Range Estimation

we-online.com/ANR010



Replacing 868 MHz Radio Modules by their 915 MHz counterparts

we-online.com/ANR015



Proprietary Migration Guide – Replacing a proprietary Radio Module by its successor

we-online.com/ANR016

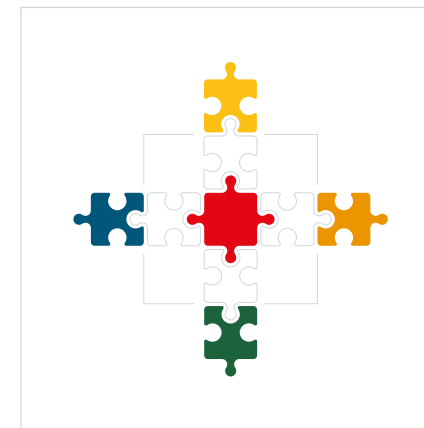

Software Development Kit

- Typically as C-Files, for mobile Apps platform specific languages
- For comfortable coding of:
 - The HOST-controller communication with the module via UART
 - PC Applications & Mobile Apps
- Code examples in Application notes and Manuals



we-online.com/WCO-SDK



github.com/WurthElektronik/WirelessConnectivity-SDK_STM32



COMBINED





FUNDAMENTALS

Why combined modules?

The combined modules from Würth Elektronik offer a combination of various protocols in just one module

Advantages

 Saving space	 Cost effective (Reducing the BOM)	 Reduction of design effort	 Full flexibility
---	---	--	---

Overview

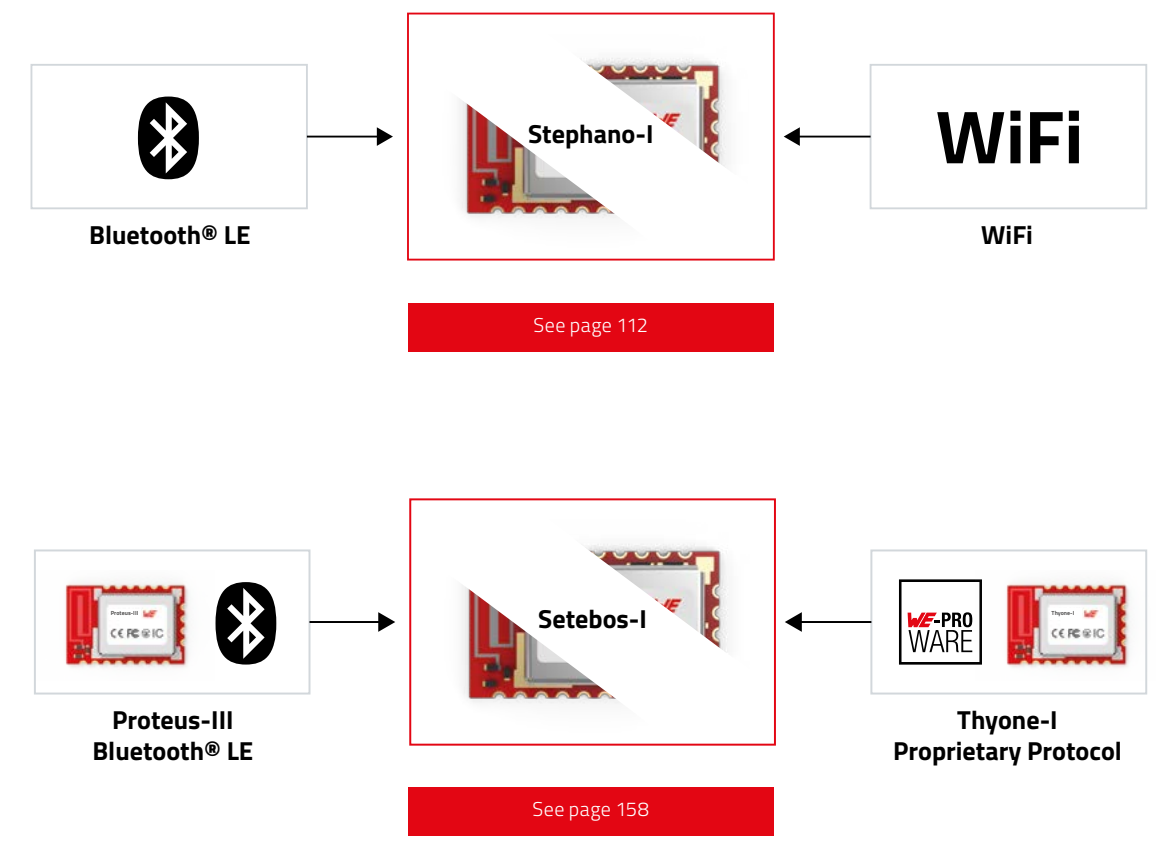

155

156

160

OUR ALLROUNDER BLUETOOTH® LE AND WIFI



Stephano-I New

2617011025000
Bluetooth® Low Energy 5.0 Standard
& IEEE 802.11 b/g/n 2.4 GHz Standard

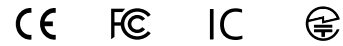

Characteristics

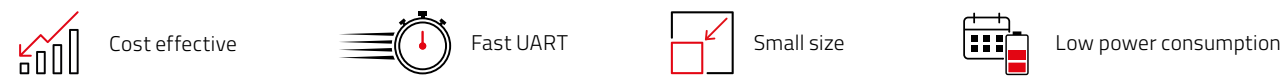

- Bluetooth® LE 5.0
- IEEE 802.11 b/g/n (2.4 GHz)
- Espressif chipset ESP32-C3
- UART interface available
- 4 MB Flash memory, 400 kB RAM
- Small size: 13 x 9.5 x 2 mm
- Integrated PCB Antenna
- Output power e.r.p.: 13.4 dBm (WiFi) / 4.5 dBm (BLE)
- FOTA functionality available
- Certifications: CE, FCC, IC, TELEC



Comparison Development Efforts

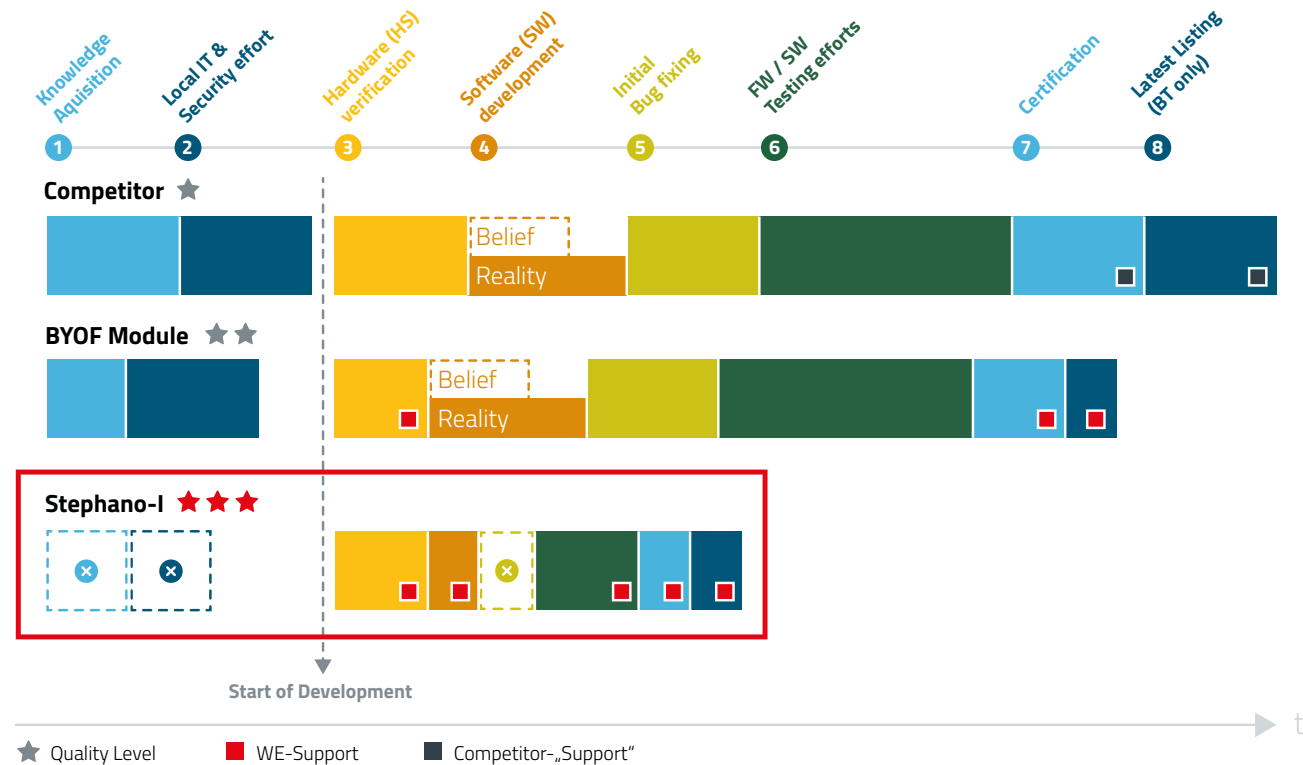

Take Away

Competitors

Fast Food

Stephano-I

Restaurant

Calypso
page: 125

Proteus-III
page: 111

ADDED VALUES

Development Tools

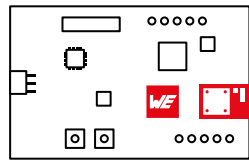

Eval Boards

- Easy testing
- Rapid prototyping
- FTDI integrated (UART to USB)
- All pins available on header
- Current measurement



we-online.com/EVAL-BLE



More information on page 16



Smart Commander

- PC-Tool for easy configuration and operation prototyping
- Automatic command creation by GUI user interaction
- Monitoring UART-Communication
- Export Commands for easy integration in the former HOST-Controller



we-online.com/SmartCommander

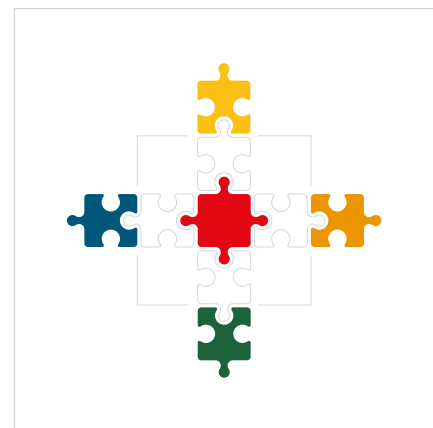

Software Development Kit

- Typically as C-Files, for mobile Apps platform specific languages
- For comfortable coding of:
 - The HOST-controller communication with the module via UART
 - PC Applications & Mobile Apps
- Code examples in Application notes and Manuals



we-online.com/WCO-SDK



github.com/WurthElektronik/WirelessConnectivity-SDK_STM32

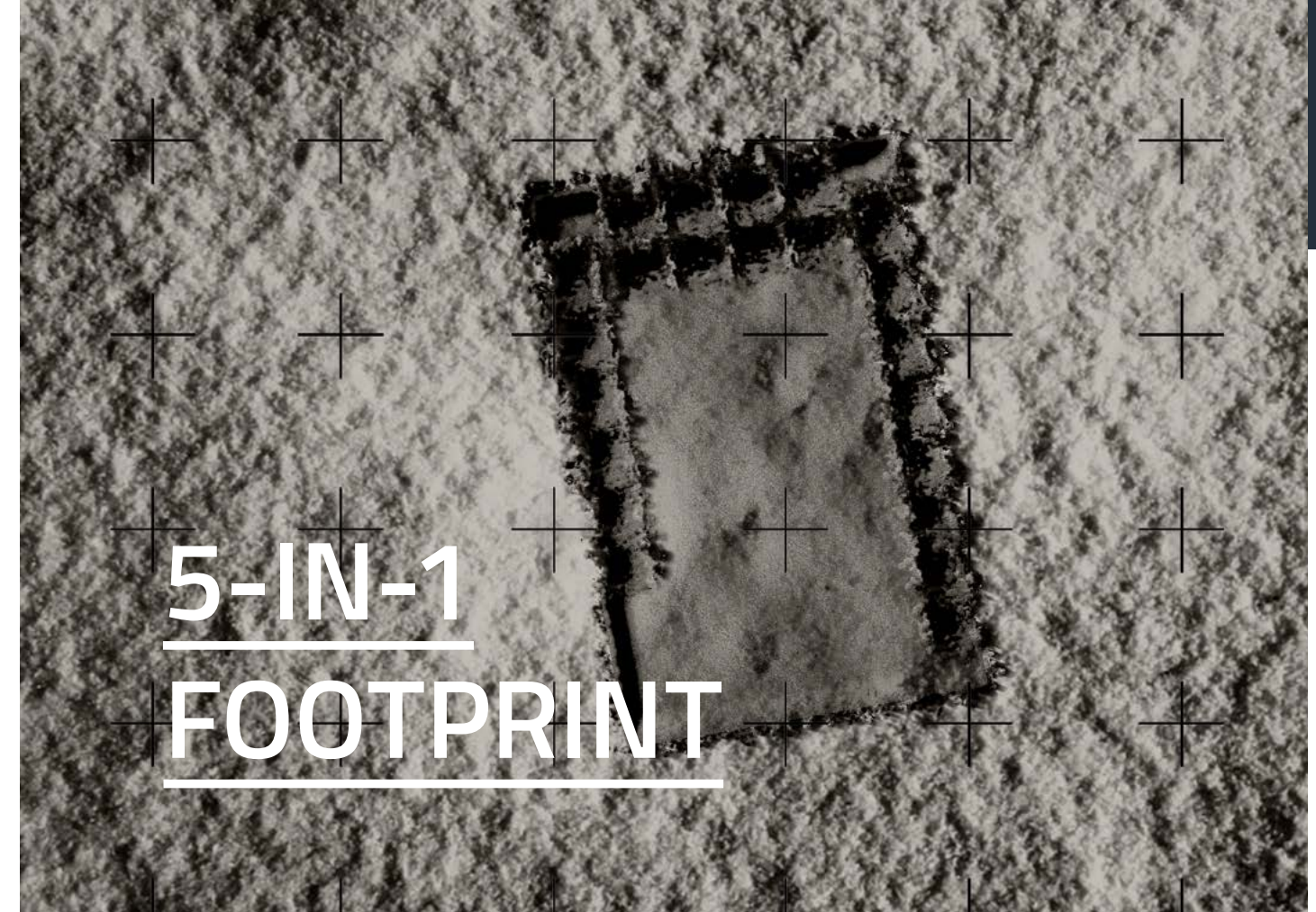

TAKE FUTURE TRENDS INTO ACCOUNT AND KEEP THE FLEXIBILITY!

Committing today on a wireless technology for tomorrow seems impossible. How nice would it be to expand your application with different radio protocols at any time without any layout changes. Würth Elektronik offers you a high degree of freedom with the radio module footprint.

It is one quality proven hardware base, that prevents you from enormous costs of re-design in future already today. Choose between a Bluetooth®, Wirepas™ or proprietary radio module or the combined variant of proprietary and Bluetooth®.

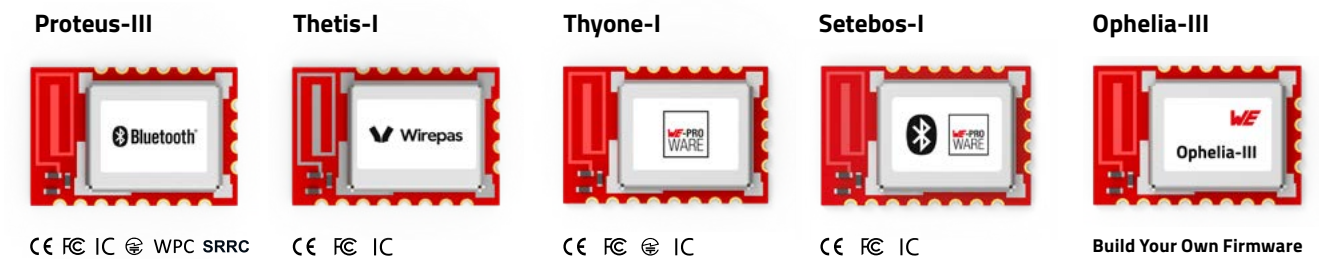

MESH



163

168

169

FUNDAMENTALS MESH OVERVIEW

What's a Mesh?

A Mesh is a network of multiple devices/nodes, where each can communicate with any other node. In general there are multiple connection paths between the source and the target node. The information is handed over from one node to the other.

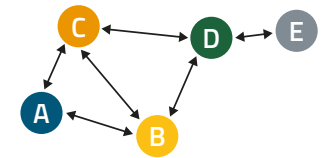

EXAMPLE Sending a message from A to D

Flooding Technique

Each node just forwards the message

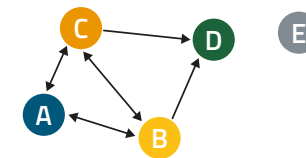

- + Easy to use:
 - No network organization (installation, change)
- + Size does not matter
- Increased traffic:
 - Duty Cycle problems

Routing Technique

The network master or each node knows the path

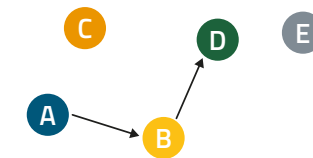

- + Shortest/Cheapest path
- Extra network organization traffic
- Size limitations (master handled)
- Less robust on network changes:
 - Master has to know when adding/removing a node

Asynchronous

Messages can be transmitted at any times



- + Fast
- + No installation effort
- + No size limitations
- Energy consuming (~100% RX)
- High probability for radio packet collision

Synchronous

All nodes are synchronized and transmit/receive at determined slots

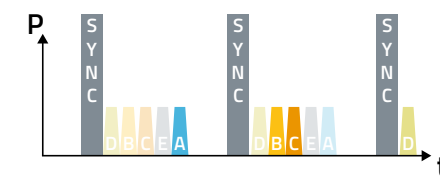

- + Energy efficient
- + Time and frequency hopping possible
- Synchronization effort (master needed)
- Size limitation
- Low throughput/High latency

WIREPAS MASSIVE

What is Wirepas?

Wirepas is an international company with headquarters in Tampere, Finland. Wirepas is specialized in IoT topics and offers the Wirepas Mesh stack (firmware only) and support to high volume customers. Würth Elektronik is in cooperation with Wirepas to integrate the Wirepas mesh stack into radio chips as well as offering service to our customers to develop Wirepas mesh radio modules based on the existing Nordic Semiconductor nRF platform. Würth Elektronik is licensed to develop, support and sell standard and custom Wirepas mesh radio modules.

What are the strengths of Wirepas Mesh protocol?

Traditional mesh networks suffer in large scale from complex networking tables, congestion and bandwidth issues. Wirepas overcomes these issues by removing network's infrastructures and decentralizing network's intelligence on the nodes. All networking decisions are done locally by the nodes. Every node:

- scans automatically the neighborhood and choose the best path to the sink
- adapts transmit power to neighbor proximity
- can act as sink, routing or non-routing node
- can work in low power or low latency mode
- chooses the best frequency to use locally
- has a high configurability, interference-tolerance, ultra-low energy consumption: Wirepas mesh software is ideal for large scale and battery-operated networks.

What is Wirepas Mesh?

Wirepas Mesh is a connectivity protocol for radio modules, optimized for large scale and energy efficient wireless mesh networks in the frequency 2.4 GHz. This innovative technology can be used to create large IoT networks, for example using battery-powered sensors, in which each node also functions as a router. On a single MCU solution, the application runs on the device itself. On a dual MCU solution, the application runs on a host microcontroller.

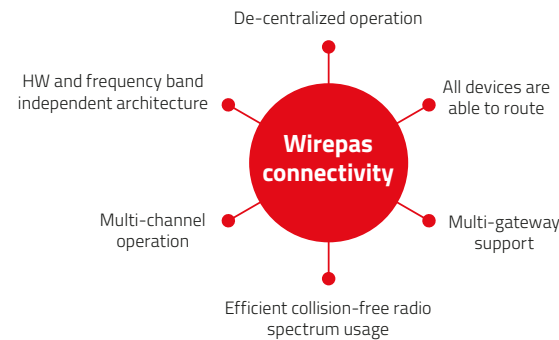

BLUETOOTH® MESH

Bluetooth® Mesh

Bluetooth® released a Mesh Version in 2017. It is an own standard which is separated from the Bluetooth LE and Bluetooth Classic standard. Nevertheless it uses Bluetooth LE physical and link layer for communication. As a flooding Mesh it includes time to live (TTL) in the messages. Security is approved by application key and network key.

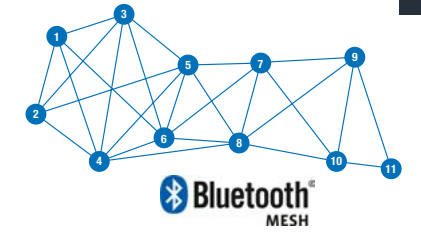

How does it work?

The Network has nodes with different features. A node sends and receives data. Additionally there are relay nodes forwarding defined data. Special Low Power nodes are rarely active and only then send/receive data. The corresponding node is the Friend collecting data for the Low Power node. Only Low Power Nodes can be operated, since other nodes permanently receive and relay data. Bluetooth® Low Energy devices (i.e. smart phones) can connect temporarily to push/pull data to/from the network. Nodes have to subscribe to groups to receive messages and publish to groups to transmit messages.

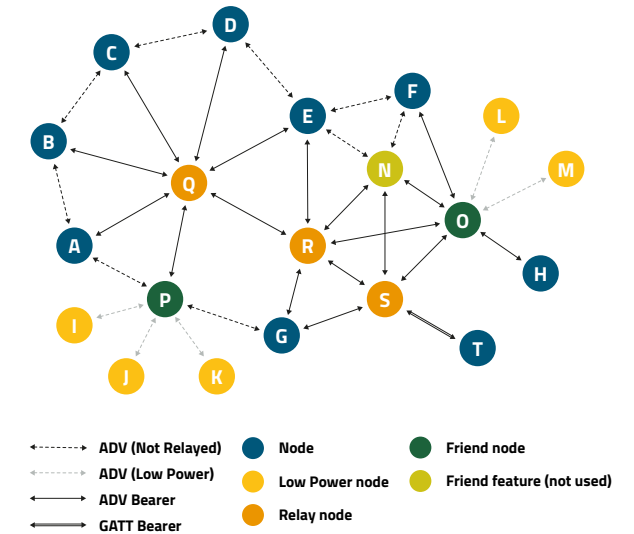

Mesh Models

Bluetooth® Mesh Models define basic functionality of nodes on a mesh network. Mesh Profile Specification defines foundation models used to configure and manage the network. Mesh Model Specification includes models defining functionality that are standard across device types. Those Models are, for example: Generics (general functions), Timing, Lighting and Sensors.



Is a Bluetooth® Mesh the best Solution for my scenario?

To sum it up, there are the following benefits and penalties in using Bluetooth® Mesh, which have to be considered:

- ➕ Extending the range by repeating messages, a self-healing network as there is the possibility of different routes of the messages make the Bluetooth® Mesh very useful.
- ➖ On the other hand it must be mentioned, that the performance of a Bluetooth® Mesh is quite poor. You could send 30 Bytes per 100 ms leading to a throughput of 2400 bps. Further, the Network must be installed by the end user himself, so technical knowhow is recommended. Furthermore each node has to be added to the network and provided with authentication and encryption keys which could make it time-consuming for the user.
- ➖ Bluetooth Mesh can be only used for applications that are supported by Bluetooth Mesh models, like Lighting applications.

Main Benefits of Wirepas Mesh

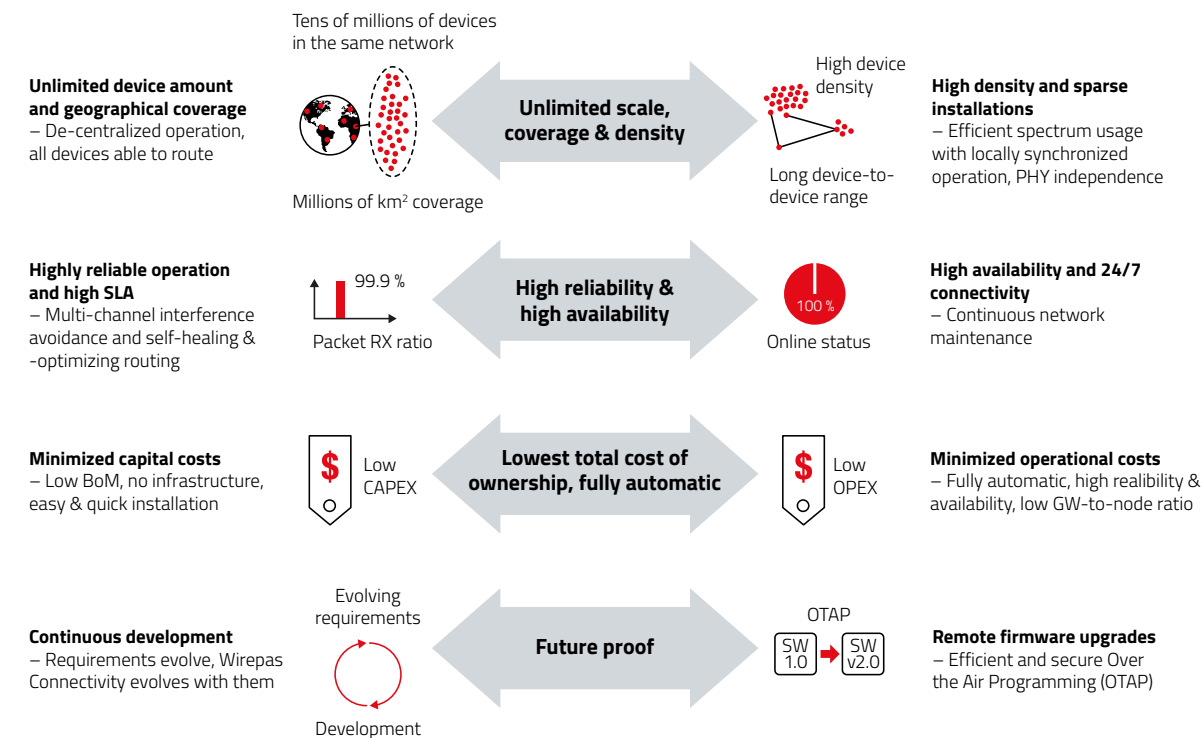

MESH IN WE RADIO MODULES

Asynchronous Flooding Mesh

An asynchronous flooding mesh is integrated into Thyone-I, Tarnos-III, Thebe-II, Thelesto-III, Themisto-I & Setebos-I.

Suited for applications:

- using small/medium size mesh networks (much traffic due to flooding technique)
- where current consumption does not play a role (always on RX or TX – no sleep/off times)



Mesh: www.we-online.com/Mesh

Comparison Bluetooth® Mesh – Proprietary Mesh – Wirepas Mesh

	Nodes	Latency	Throughput	Power	Costs
Bluetooth® Mesh	😊	😡	😡	😊	😊
Wirepas Massive	😊	😡	😊	😊	😊
WE Proprietary Mesh	😊	😊	😊	😡	😊
Zigbee	😊	😊	😊	😊	😊
Thread	😊	😊	😊	😊	😡

Comparison Asynchronous Flooding & (A)Synchronous Routing

We need a mesh solution that covers large power sensitive applications. Suited for applications that are battery operated, like sensor networks. Routing mesh integrated into Thetis-I.

	e.g. Thyone-I / Tarnos-III	Wirepas TDMA	Wirepas CSMA-CA
Latency	😊	😊	😊
Current consumption	😡	😊	😡
Throughput	😊	😡	😊
Maximum number of nodes	😊	😊	😊
Installation effort	😊	😊	😊
Robustness	😊	😊	😊

	WE Radio Module
Latency	😊
Current consumption	😡
Throughput	😊
Maximum number of nodes	😊
Installation effort	😊
Robustness	😊

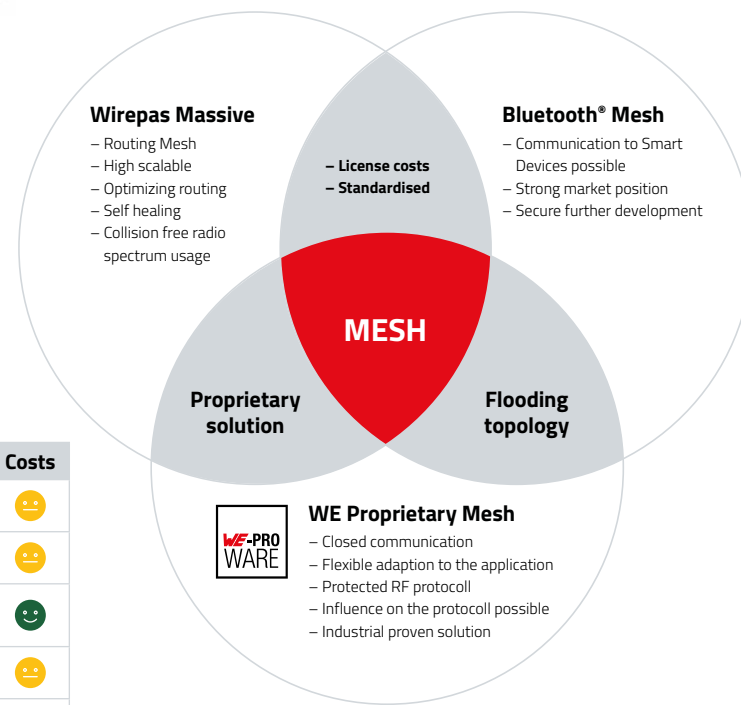

ACCESSING WIREPAS MASSIVE TECHNOLOGY

Wirepas partner

Acting as Wirepas partner, Würth Elektronik delivers modules with Wirepas firmware pre-flashed on the well-proven Thyone-I/Proteus-x hardware platform. Through a unique cooperation model, Würth Elektronik makes the advantages of the Wirepas technology accessible to small and middle sized businesses.



WE Wirepas

No License agreement or monthly rate – ONLY Royalty per piece (2.50 €)

Paid from customer to WE, from WE to Wirepas. Focus on small- and medium-size customers with no MOQ.

Wirepas + Competitor

License agreement with Wirepas needed. Including monthly rate: Royalty per piece (2.50 €)

Wirepas cannot follow and support customers requiring small quantities.

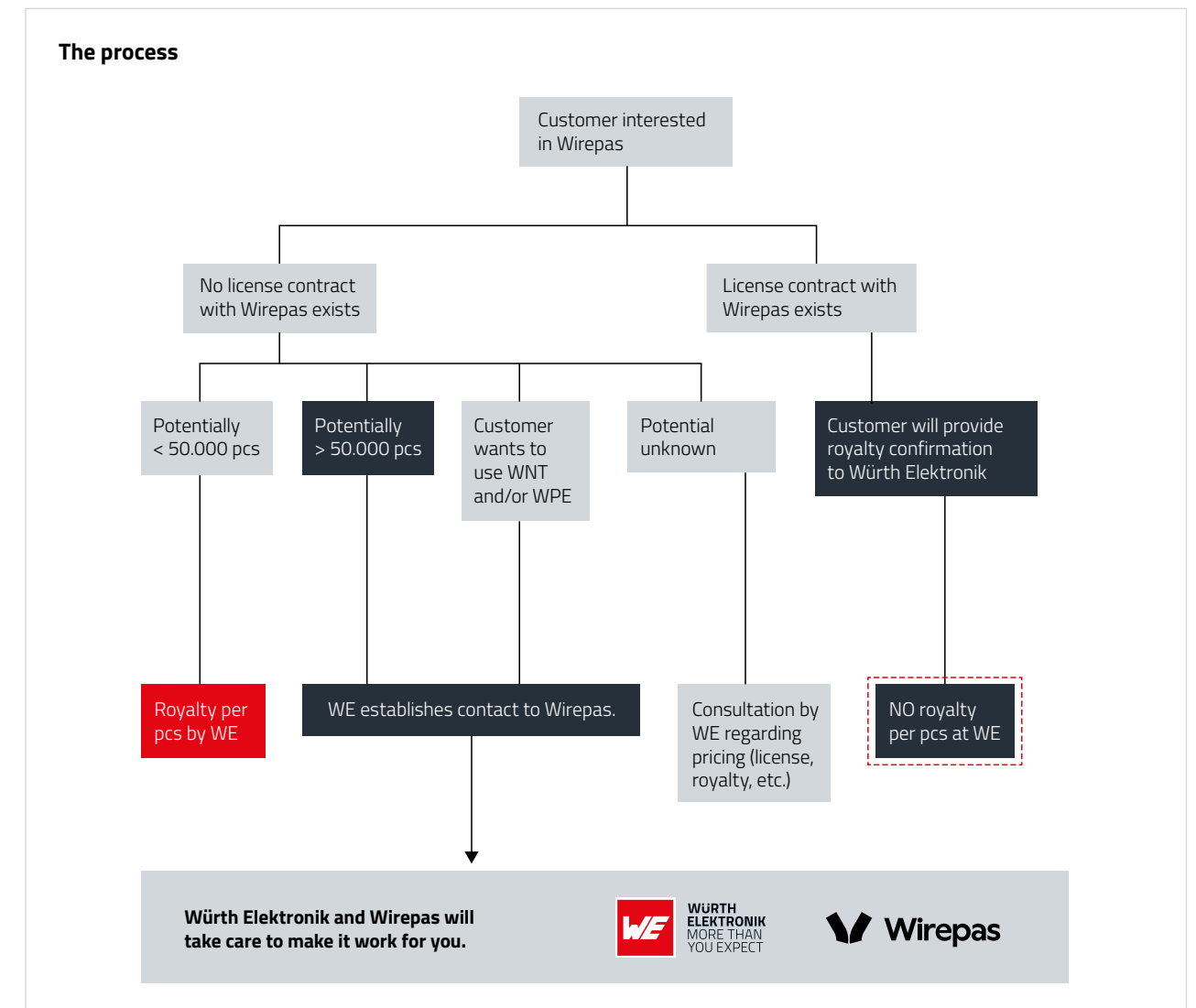

OUR MESHED WIREPAS 2.4 GHz



Thetis-I

2611011021010
Radio Module 2.4 GHz with Wirepas Mesh protocol

CE FC IC UK WPC

What are the key points from customer's perspective?

- ✓ Throughput
- ✓ Maximum number of nodes
- ✓ Installation effort
- ✓ Robustness



Characteristics



- Wirepas routing mesh
- Low energy and low latency mode
- Standalone (Single-MCU) or host-controlled (Dual-MCU) operation
- Standard or custom firmware solution available
- Nano SIM size - 8 x 12 x 2 mm
- ARM® Cortex®-M4 32-bit processor with FPU, 64 MHz
- ARM Cryptocell cryptographic unit
- Nordic Semiconductor SoC nRF52840
- 1 MB flash memory, 256 kB RAM
- Wirepas „Dual CPU“ model, c-mesh api for hosts available through github (<https://github.com/wirepas/c-mesh-api>)
- +6 dBm TX power (ERP: 4 dBm)
- Encryption, Integrity & Authentication
- Smart antenna selection (2-in-1 Module)
- Also available as proprietary radio module (Thyone-I) or Bluetooth® LE radio module (Proteus-III)
- CE, FCC, IC, UKCA and ETA-WPC certification



Thetis-I:
www.we-online.com/Thetis-I

Grow your Industrial IoT endlessly

The possibilities to use an industrial IoT mesh network in production are endless. The Wirepas Mesh grows organically and has automated interference avoidance so one network can handle multiple use cases and thousands of assets.

Benefits of Industrial IoT



Battery Lifetime

No additional mains-powered routers are required. Only large-scale wireless mesh connectivity technology in the market enabling battery-operated routers with over 5 year lifetime with 4000 mAh battery (1,5 packets per second).



Easy Retrofit

Easy retrofit is required due to factory floor design, large number of unsensored machinery and large number of outdated sensors that need replacement. Easy battery-operated mesh network with our sensors can be installed by anyone and anywhere.



Security & Reliability

Includes self-healing routing, multi-channel operation with local channel white/blacklisting. Proven over 99.99% reliability in large-scale & high interference buildings. Secure connectivity with industry standard AES-128 encryption.



Future Proof

Enables not only lighting control, but environmental sensing and asset tracking in the same wireless network. Any device in the network can be updated over the air. Interoperable with BLE devices.

Source: <https://wirepas.com/applications/industrial-iot/>

ADDED VALUES

Development Tools

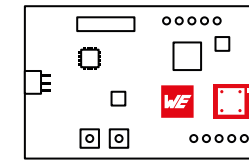

Eval Boards

- Easy testing
- Rapid prototyping
- FTDI integrated (UART to USB)
- All pins available on header
- Current measurement



we-online.com/EVAL-Mesh



More information on page 16

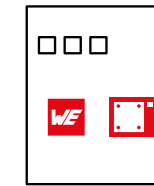

Sensor Node

- Easy testing
- Sensors onboard
- Rapid prototyping
- CR2032 battery powered
- setup Wirepas network immediately



we-online.com/Sensor-Node



More information on page 16

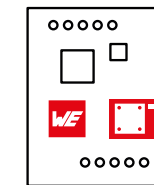

Mini Eval Boards

- Small and cheap
- USB connection with FTDI-cable possible (available as accessory)



we-online.com/EVAL-Mesh



More information on page 16



USB-Radio Stick

- USB-FTDI-RF-Module
- Simple radio connection for computer



we-online.com/USB-Mesh



More information on page 16



Wirepas Commander

- Easy testing
- Automatic command creation by GUI user interaction
- Monitoring UART-Communication
- Export Commands for easy integration in the former HOST-Controller

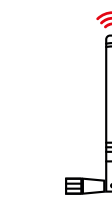
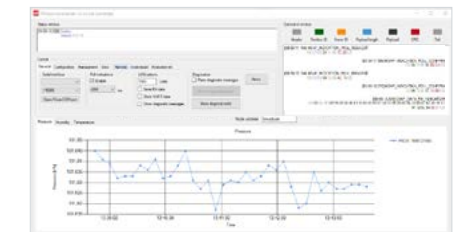

Antenna

- 2.4 GHz external Antenna Himalia

USER APPLICATION INDUSTRIAL IOT

Wirepas Mesh is the perfect fit for Industrial IoT

The manufacturing industry has started seeing a growing need for monitoring the condition of their assets and to perform predictive maintenance if needed. The challenge is that smart industries require an industrial IoT connectivity solution, a self-healing mesh network that can handle a demanding radio environment.

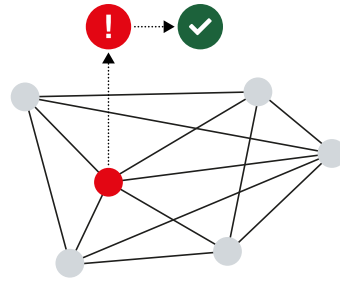

Predictive Maintenance

Machines, devices and equipment in production are lasting investments and keeping them operative is key. The sensors measure the condition data for the machines, devices and equipment and trigger predictive maintenance if needed. This reduces the need for multiple days of production halt to a few hours of maintenance.

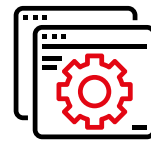

Leakage Control

Pipes, ducts and vents carry and control many gas and liquid in production and from production plants to use. Monitoring and controlling valves and levers with sensors to ensure there are no leakages saves both money and the environment. The high number of sensors require a robust IoT connectivity to operate securely.

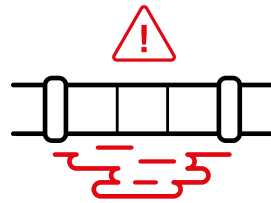

Monitoring and Measuring of Material Levels and Condition

Tanks, containers, vessels and sewage systems may carry dangerous liquids, gasses or material and the use levels need to be ensured to make sure safety and productivity is in check. Sensors may also keep tabs on for example safe temperature or ambient light levels to prevent accidents from happening.



RedLore – Container Tracking

RedLore Smart Sensors can be used in a large range of applications thanks to the wide variety of built-in sensors.

The Smart Sensors have the Wirepas Mesh Network Communication protocol inside: Every device is a wireless router and can act as a repeater for other nodes. As a result very large physical networks with 1000's of nodes can be built as long as every node can connect to a node which is closer to the gateway. At the same time every node remains low power and can work uninterruptedly for years on a small battery.

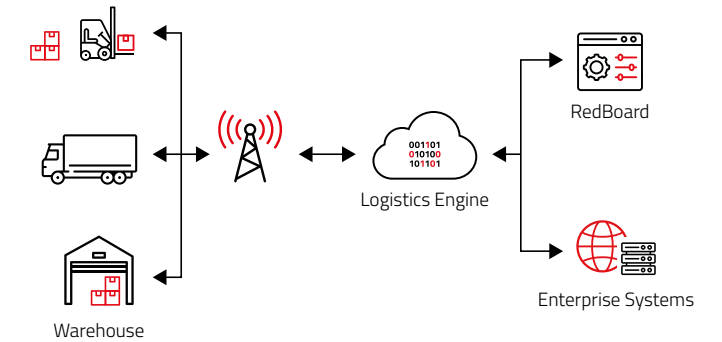

Different variants are available, each with different sensor sets and a long-life industrial LiSOC12 battery for up to 10 years of battery life. The sensing parameters (e.g. update rate) can be changed to suit the application needs.

The Smart Sensors send their data to a gateway. The accompanying Mobile App connects through the built-in NFC 'tap'- interface, allowing configuration and diagnostics of a device. The same functions are available from the gateway using the Remote Functions API.

Condition Monitoring

Condition monitoring can be expensive - which is why up to 95 percent of all aggregates in a production plant aren't monitored or are monitored sporadically, which leads to high risks for unplanned downtimes.

With a condition monitoring system you can monitor hundreds of aggregates within a few hours. Thus monitoring is simple, fast and cost-efficient.

The expandable system works for almost all aggregates and detects potential damage, imbalances and misalignments already weeks in advance.

The final end solution can consist of:

- Wireless sensors to monitor machine and equipment data
- A gateway that receives the sensor data and transmits it into the cloud
- A digital service that evaluates this data and provides professional error analyses - comfortably via smartphone or desktop application

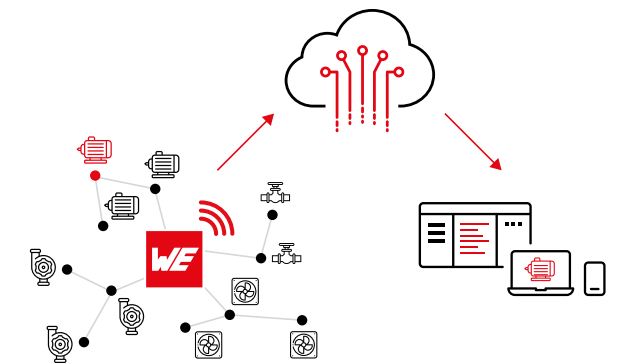

WIRELESS M-BUS



173

175

177

FUNDAMENTALS

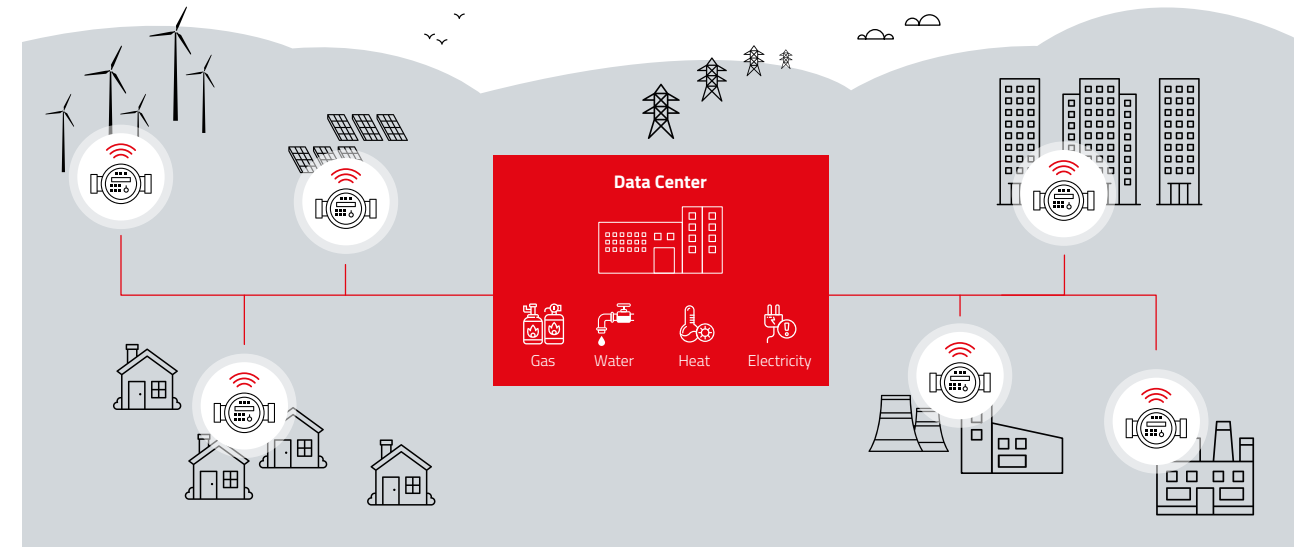

Wireless M-Bus

Wireless Meter Bus (wM-BUS) is the extension of the Meter Bus (M-BUS) with a wireless protocol and role scheme for handling communication over a standardized wireless communication interface between meters and data loggers – so called smart meter gateways (SMGW). This scheme is specified by the European standard EN 13757 and its sub-standards. The motivation of this standard is to allow an automated measuring and processing of data, track the usage of resources and to optimize provisioning in order to create an “Advanced Metering Infrastructure” (AMI).

Such Smart grid / meter devices are typically battery operated and in need for a long range and robust wireless communication. This is the reason for using the sub-GHz frequencies in the free ISM Bands. EN13757-4 is specifying radio options in the 169 MHz, 434 MHz or 868 MHz bands.

In between those frequencies there are different modes with different functions. In the table below you can see those specifications.

Mode	Uplink Parameters	Downlink Parameters
S	868.3 MHz, 16.384 kbit/s, Manchester	868.3 MHz, 16.384 kbit/s, Manchester
T	868.95 MHz, 66.667 kbit/s, 3-out-of-6	868.3 MHz, 16.384 kbit/s, Manchester
C	868.95 MHz, 100 kbit/s, NRZ	869.525 MHz, 50 kbit/s, NRZ

GENERAL INFORMATION

Uni- / Bidirectional

The wireless M-Bus (EN13757-4) differentiates the transfer in a network in 2 directions: uplink and downlink. Where uplink is used when a "meter" device sends data to a gateway ("other") and downlink is used when a gateway ("other") sends data to a "meter".

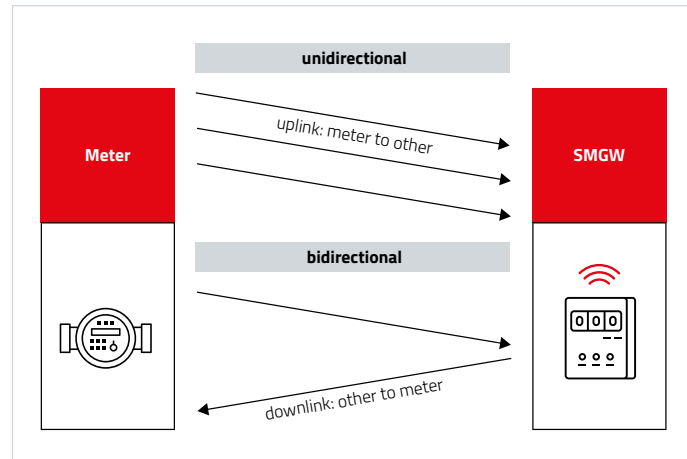

These two directions are, depending on the wireless M-Bus mode, either symmetric (S and N modes) or asymmetric (T and C modes). Where symmetric means that the same radio parameters (radio data rate, coding, modulation, frequency) are used for both directions – uplink and downlink. On the other hand, asymmetric means that those radio parameters are different.

A wireless M-Bus mode labeled with a '1' in the name (e.g. C1 meter) indicates that the device is a sender only and will not receive any radio frames. Whereas a wM-BUS mode with a '2' in the name (e.g. C2-other) means the device can operate as sender and receiver.

The 'sender only' mode of operation, such as C1 meter, is suitable for battery-operated meters that do not require any information in the downlink direction. These meters are usually designed to operate for at least 10 years with the integrated battery. Currently, the majority of smart meters utilize the C mode, specifically the C1 meter mode.

Data collectors or gateways typically receive T and C mode meter frames in a single mode of operation. This is possible since both physical layers only differ in the coding.

Payload

The payload of a wireless M-Bus frame is coded according to EN13757-3. Any meter reading value is located in one data block and the frame can contain one or multiple of such blocks. This allows the meter reading values to be transferred efficiently and in a well-defined yet flexible manner to provide interoperability. The drawback of this is, that the raw data of a wM-BUS frame is not readable for a human without parsing the data back into a readable format.

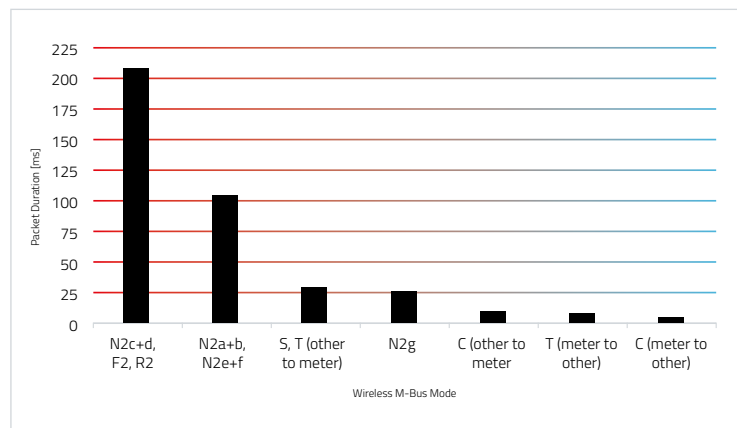

Different "Standards" in Europe



Europe in general

- EN13757; 169, 434 and 868 MHz wM-BUS Modes
- Based on OMS group recommendations



France



- „GrDF“ (Gaz réseau distribution France)
- EN13757 N-Modus, 169 MHz narrow band



Italy

- „CIG“ (Italian Gas Committee)
- Italian UNI TS11291 Specification
- EN13757 N-Modus, 169 MHz narrow band

PRODUCT OVERVIEW

			
	Mimas-I	Metis-I	Metis-II
Order Code	2607011113000	2605041183000	2607021183000
Frequency	169 MHz	868 MHz	868 MHz
Wireless M-Bus modes	N (a to f)	S, T, C	S, T, C
Output power	14 dBm	11 dBm	14 dBm
Power Consumption Rx	28 mA	22 mA	30 mA
Power Consumption Tx	59 mA	31 mA	53 mA
Power Consumption Sleep	10 µA	0.3 µA	3 µA
Supply Voltage min - max	2.0 - 3.6 VDC	2.2 - 3.6 VDC	2.0 - 3.6 VDC
Op. Temp	-40 ... +85 °C		
Max Datarate	4.8 kbps	100 kbps	100 kbps
Payload	255 Byte	255 Byte	255 Byte
Antenna	external		
LoS Range	3000 m	700 m	1000 m
LoS Test Conditions	2 m Antenna height / 2400 bit/s	2 m Antenna height / 32768 bit/s	2 m Antenna height / 32768 bit/s
Transparent Mode	✓	✓	✓
Interface	UART		
Certification	CE		



Mimas-I:
www.we-online.com/Mimas-I



Metis-I:
www.we-online.com/Metis-I



Metis-II:
www.we-online.com/Metis-II

OUR ANALYZER

WM-BUS TOOL

Wireless M-Bus Analyzer

The Wireless M-Bus Analyzer is a tool for receiving and parsing wireless M-Bus telegrams that comply with EN 13757-4:2013 transmitted by devices with role „meter“. It supports receiving Uplink telegrams in accordance with the OMS specification Generation 4 and EN13757-3.



The data records in the telegrams are displayed in plain text by means of the integrated parser, which greatly simplifies the interpretation of a telegram. A review of the configuration settings or, for example, the meter readings can therefore be completed simply.

The Wireless M-Bus Analyzer is an excellent tool for analyzing errors and RF range of M-Bus devices. Thanks to the simplified representation and an integrated logging function, data can also be analyzed later.

The software only works in combination with a licensed USB stick. This USB stick acts as the receiver for telegrams from the meters and supports the S-, T- and C-mode.

Name	Part No.	Frequency [MHz]	Range* [m]	Modes	Compatible Modules
Metis-Simulator	2607056283011	868	800	S, T, C	Metis-I, Metis-II
		Wireless M-Bus Simulator Plug transmitting simulated meter frames in S-, T-, C-mode for range estimation and meter simulation			
Metis-Analyzer	2607057283011	Wireless M-Bus Receiver Plug plus smart meter software analyzer tool for wireless M-Bus. One analyzer tool license is installed on the Receiver Plug			

* Range stated is calculated assuming line-of-sight. Antenna above ground 1.5 m and 6 dB margin. Actual range will vary based upon specific board integration, antenna selection and environment.

Characteristics

- Tool for monitoring and analysis of wireless M-Bus communication
- Packet content visualization
- Supports data according to EN13757-3 and OMS
- Message parser for deep packet analysis incl. M-Bus application layer
- Decryption function (AES128) for security profiles A and B (encryption modes 5 and 7)
- Log feature (.xlsx, MS Excel) for offline analysis
- Various wireless M-Bus modes supported (S-, T- and C-Mode)

 we-online.com/wM-Bus-Analyzer

ADDED VALUES

Development Tools

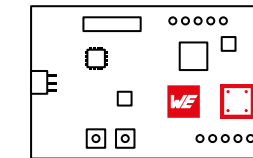

Eval Boards

- Easy testing
- Rapid prototyping
- FTDI integrated (UART to USB)
- All pins available on header
- Current measurement



we-online.com/EVAL-wM-BUS



More information on page 16



USB-Radio Stick

- USB-FTDI-RF-Module
- Range extension in Flooding Mesh networks
- Simple radio connection for computer



we-online.com/USB-wM-BUS



More information on page 16

AppNotes



ANR001 Metis-II Repeater Mode

we-online.com/ANR001

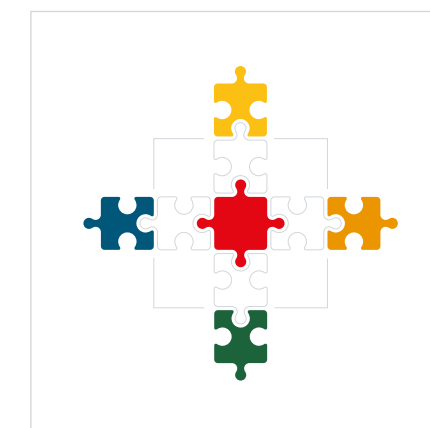

Software Development Kit

- Typically as C-Files, for mobile Apps platform specific languages
- For comfortable coding of:
 - The HOST-controller communication with the module via UART
 - PC Applications & Mobile Apps
- Code examples in Application notes and Manuals



we-online.com/WCO-SDK



github.com/WurthElektronik/WirelessConnectivity-SDK_STM32



A meter billing service provider switches from yearly manual reading to the use of wM-BUS based heat cost allocators and a smart meter gateway.

Advantages for the Customers

- + „Almost live“ data access on his currently use of resources including a “live” cost estimation instead of yearly billing
- + Comparison on a day-by-day basis when data is available
- + No costs for the manual readout, no huddle with a yearly appointment for manual meter readout person
- + Secure due to encryption, only the owner of the data knows the key required for decrypting the messages of the meters
- + Several metering providers can share a single Smart meter Gateway (water, gas, electricity, heat cost, ...)

Disadvantages for the Customers

- High initial costs: Smart meter gateway and meters with wireless interface
- Battery lifetime requires exchanging devices each 7 - 10 years in case of battery operated devices – due to security reasons “just” changing the battery is often prevented

The typical use-case contains only the transmission from the meter to the data logger, but no transmission from the data logger to the meter. Each meter sends a message in a certain period. This period always contains a randomly chosen part to avoid permanent collisions between two devices. This period varies according to the medium: for electricity the OMS recommends 7.5 minutes, for water 30 minutes and for heat cost allocators 240 minutes.

Metering media	Mandatory (billing and actuator)		Informative aspects (consumer)
	Average update interval maximum [min]	Visualization interval for energy provider [hour]	Visualization interval for consumer [min]
Electricity	7,5	1	15
Gas	30,0	1	60
Heat (district heating)	30,0	1	60
Water / Warm water	240,0	24	–
Heat cost allocators	240,0	24	–
Heat / Cost (sub metering)	240,0	24	–
Repeater*	240,0	–	–

* Limit refers to datagrams that are generated by the repeater itself. Not for repeated datagrams!
Source: OMS spec generation 4, volume 2 issue 4.2.1

The data logger forwards the (still encrypted) data to a data center or a smart meter gateway, which can also decrypt the data locally because it has received the keys of the meters through the exchange with this data center. The permitted procedure is also country-specific in Europe.

Advantages



Time saving



No personal contact needed



Autonomous



Measuring possible at any time



Smart metering: Measure and control

BUILD YOUR OWN FIRMWARE



181

184

189

FUNDAMENTALS

Build Your Own Firmware

With our portfolio of BYOF modules, e.g. Ophelia-I, customers can receive a radio module in hardware-only version, meaning that the firmware for the transceiver chipset is developed by the customer himself. Any of our radio modules with integrated flash memory can be utilized for the BYOF approach.

A custom firmware:

- Can be developed using the SDKs and resources which are provided by the SoC manufacturer. In case of Ophelia-I and Proteus it's either the nRF5 SDK or nRF connect SDK by Nordic Semiconductors
- Defines the functional characteristics and specifications of the radio module
- Can be optimized to the specific application, such as allowing hostless operation or sensor connection

Compared to that Proteus-e, Ophelia's twin, is based on the same hardware but coming with a Bluetooth® 5.1 firmware. Proteus preinstalled firmware comes with some advantages regarding the reduction in development effort and risk for the customer. Considering the task to add a radio communication to the application, the resources required for firmware development or for module's certification are negligible. And thanks to the Wireless Connectivity SDK using the API of any wireless module from Würth Elektronik with your host IC is an easy task for developers.

If you have your custom firmware ready for either of our module hardware platforms, we can take care of the flashing and produce your custom module in the quantity you need.

	Standard module	Build your own firmware BYOF-module
Firmware	Standard firmware	No firmware
Fully certified / ready to use	✓	Certification can be inherited under specific conditions
Flexibility / optimization to end application	++	+++
Module's price	€€	€
Würth Elektronik's firmware service available	✓	✓

BUILD YOUR OWN FIRMWARE

With these SDKs, customers can build their firmware for the nRF52 chipset family and integrate the required functions, for example:

- Possibility to integrate device application into the module and thus save PCB space, reduce power consumption and limit the amount of parts in the circuit/ the BOM.
- Define your own Bluetooth LE profiles and characteristics, make application optimized Bluetooth LE settings or even use another radio protocol such as Bluetooth MESH, Matter, Zigbee or Thread (depending on the modules HW possibilities!)
- Use UART, SPI, I²C and/or ADC to read sensor data
- Implement application-dependant and optimized behaviour and data processing
- Implement test modes for radio certification and end device testing



The custom firmware can be tailored to the customer's application.

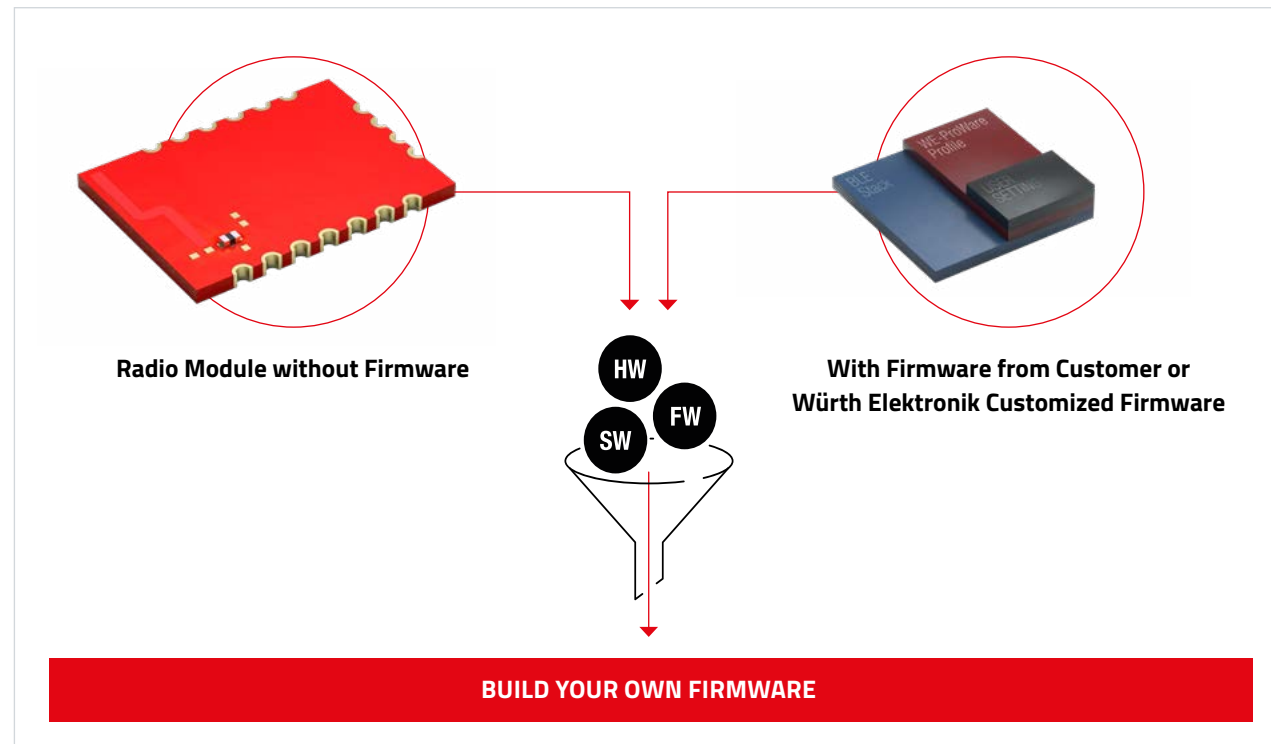

Possibilities with the Nordic SDK (nRF5 SDK, nRF Connect SDK)

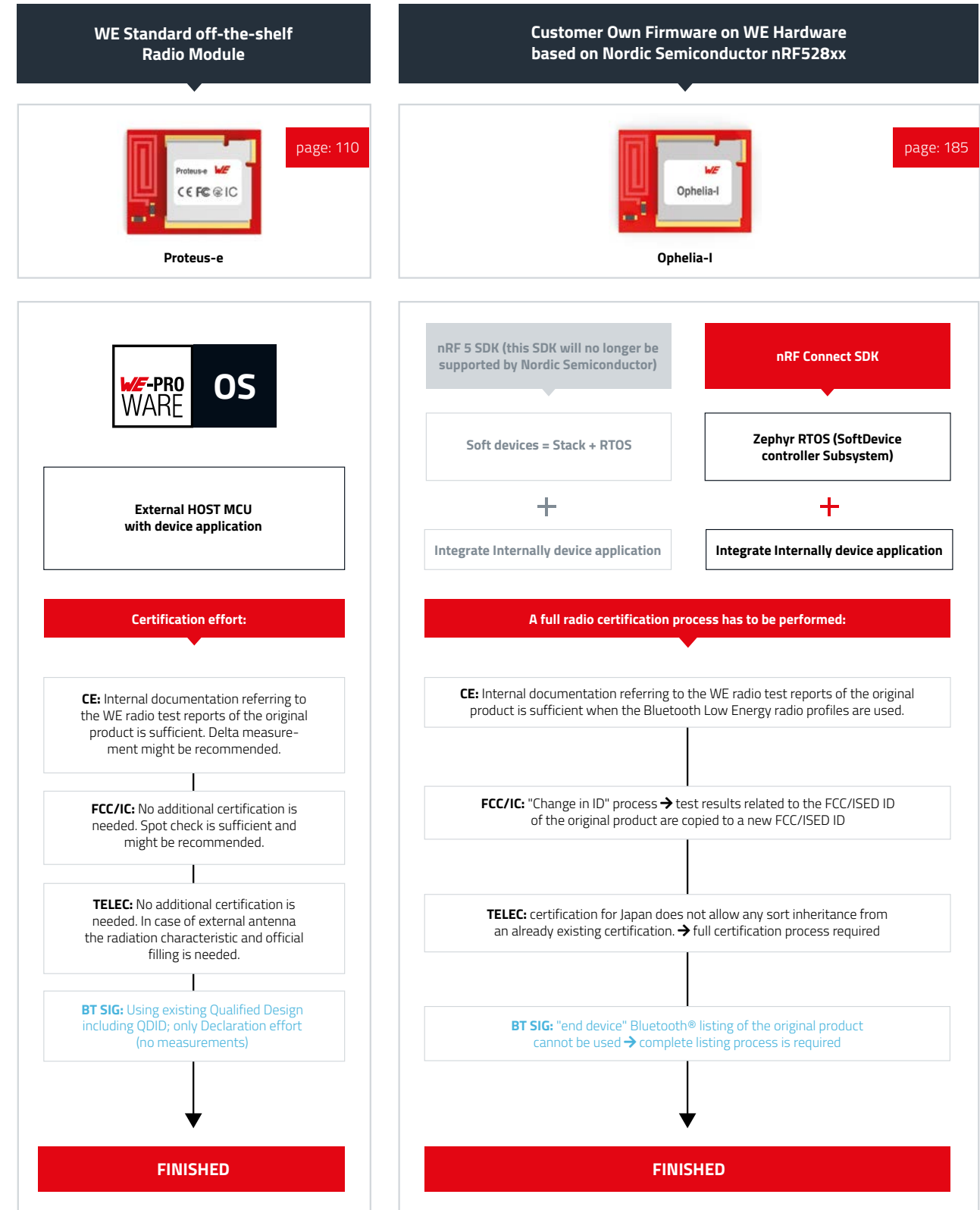

OUR INDEPENDENT: NO FIRMWARE



Ophelia-I

2612011022000
Hardware-only module based on Nordic nRF52805 radio chipset



Characteristics



- Hardware only: no firmware implemented on the module
- Optimization of the firmware to end application
- Nordic resources and SDK for development
- Bluetooth® Low Energy and Proprietary protocols supported
- Miniaturized design - 7 x 9 x 2 mm
- Smart antenna selection (2-in-1 Module)
- Nordic Semiconductor SoC nRF52805
- 64 MHz Arm® Cortex®-M4 processor
- 192 kB flash memory, 24 kB RAM
- 10 configurable GPIOs
- 0.3 µA sleep current (system off mode)
- Cost effective solution
- Ready for CE/RED, FCC, IC, ETA-WPC and TELEC certifications
- Same hardware platform available as Bluetooth® 5.1 module (Proteus-e)
- Firmware flash service by Würth Elektronik available



Ophelia-I:
www.we-online.com/Ophelia-I



Ophelia-III

2611011022000
Hardware-only module based on Nordic nRF52840 radio chipset



Characteristics



- Hardware only: no firmware implemented on the module
- Optimization of the firmware to end application
- Nordic resources and SDK for development
- Bluetooth® Low Energy and Proprietary protocols supported
- Miniaturized design - 8 x 12 x 2 mm
- Smart antenna selection (2-in-1 Module)
- Nordic Semiconductor SoC nRF52840
- 64 MHz Arm® Cortex®-M4 with FPU
- 1024 kB flash memory, 256 kB RAM
- 17 configurable GPIOs
- 0.4 µA sleep current (system off mode)
- Ready for CE/RED, FCC, IC, SRRC, ETA-WPC and TELEC certifications
- Same hardware platform available as Bluetooth® 5.1 module (Proteus-III)
- Firmware flash service by Würth Elektronik available



Ophelia-III:
www.we-online.com/Ophelia-III

STEP BY STEP

How to develop a Firmware on Ophelia-I

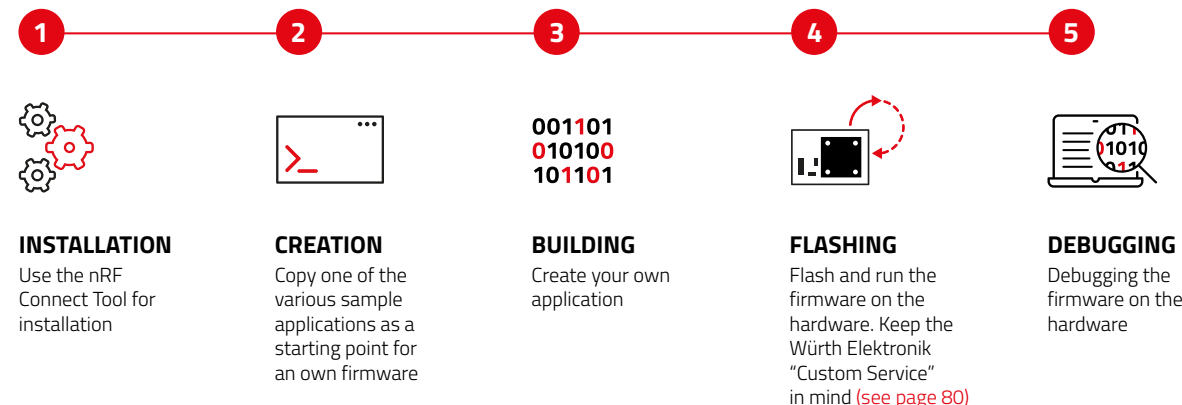

OUR INDEPENDENT: NO FIRMWARE



Orthosie-I
2617011022000
Bluetooth® Low Energy 5.0 Standard
& IEEE 802.11 b/g/n 2.4 GHz Standard



Characteristics

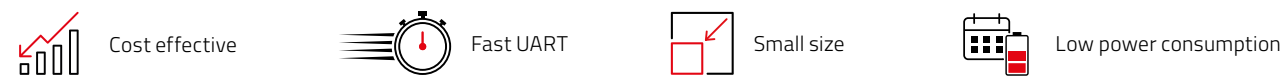

- Espressif chipset ESP32-C3
- 4 MB Flash memory, 400 kB RAM
- Small size: 13 x 9.5 x 2 mm
- Integrated PCB Antenna
- Output power e.r.p.: 13.4 dBm (WiFi) / 4.5 dBm (BLE)



Orthosie-I:
www.we-online.com/Orthosie-I

Comparison Development Efforts

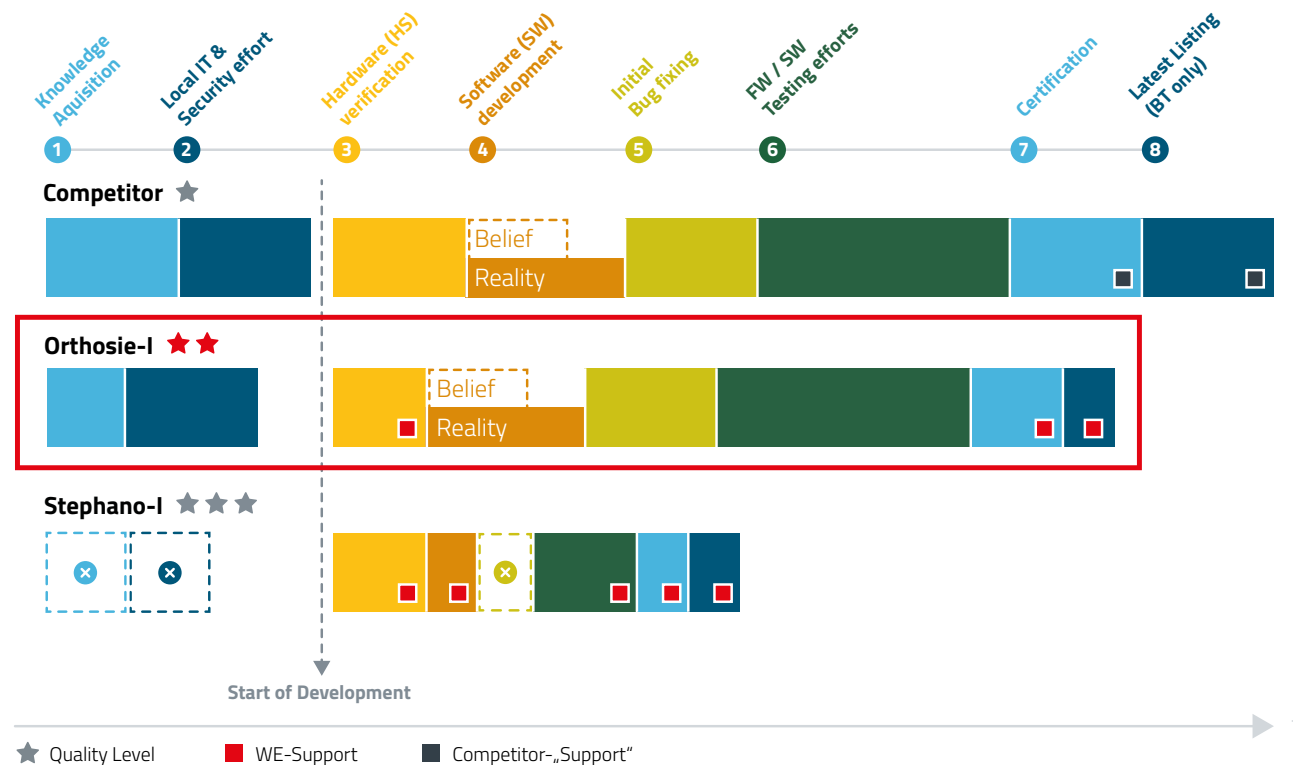

	Ophelia-I	Ophelia-III	Orthosie-I
Order Code (PCB Antenna)	2612011022000*	2611011022000*	2617011022000
Order Code (RF-Pad)			-
Chipset	nRF52805	nRf52840	ESP32-C3FH4
Possible protocols and technologies	Bluetooth® LE, proprietary protocol	Bluetooth® LE, Thread, Matter, Zigbee, Ant+, proprietary protocol	Bluetooth® LE, Thread, Matter, Zigbee, Ant+, IEEE 802.11 b/g/n
Output power [dBm]	BLE = 4	BLE = 8	WiFi = 13.4 BLE = 4.5
Power Consumption Rx [mA]	BLE = 6.8	BLE = 7.7	WiFi = 81 BLE = 82
Power Consumption Tx [mA]	BLE = 9.3	1BLE = 8.9	WiFi = 167 BLE = 161
Power Consumption Sleep [µA]	0.3	0.4	BLE = 5
Supply Voltage min - max [V]	1.8 - 3.6		3.0 - 3.6
Op. Temp [°C]	-40 ... +85		
Antenna (PCB, RF-Pad, SAS*)	SAS*	SAS*	PCB
GPIO	10	17	15
Certification (can be inherited under specific conditions)	CE, FCC, IC, TELEC, ETA-WPC, NCC	CE, FCC, IC, TELEC, UKCA, SRRC, ETA-WPC	CE, FCC, IC, TELEC

* SmartAntennaSelection

	Proteus-e Radio Module 2.4 GHz with Bluetooth® LE 5.1 Radio Protocol	page: 110
	Proteus-III Radio Module 2.4 GHz with Bluetooth® LE 5.1 Radio Protocol	page: 111
	Stephano-I Radio Module 2.4 GHz with IEEE 802.11 b/g/n WiFi and Bluetooth® LE 5.1 Radio Protocol	page: 112

CERTIFICATION OF BYOF MODULES

In case customer writes his own firmware, he is fully responsible for the certification of the product. Würth Elektronik eiSos is excluded from any conformity responsibility, but will give firmware design hints that make certification easy. In general it is not possible to reference the certificates or tests of the original product. But, in case the custom firmware does not change the radio behaviour w.r.t. original product, it is possible to reference to its certificates and test reports. Thus products with standardized radio protocols (e.g. Bluetooth®) are suited for the development of radio equivalent custom firmware. To prove that, the most convenient way is to use the same radio stack and configuration as used in the standard product of Würth Elektronik eiSos. This shows that custom firmware is radio identical with the Würth Elektronik eiSos original product.

For **RED (Europe), FCC (USA), IC (Canada), UKCA (Great Britain)** a **declaration of identity** must be done in case the custom module is **radio identical** to the standard module. TELEC (Japan) does not provide this opportunity.

Radio identical:

Radio of the custom module must respect the maximum TX power, duty cycle and radio profiles (Bluetooth LE 1 Mbit for example) as specified in the AppNote ANR031.

Excerpt AppNote

Certification of custom modules

Proteus-e, Ophelia-I	<ul style="list-style-type: none"> • Using Bluetooth® LE radio of the nRF52805 • Using 1 MBit or 2 MBit phy • Output power register of the radio chip set to maximum 4 dBm • Maximum duty cycle of 25 % • Use Bluetooth® LE stack Nordic Semiconductor S112 in version 7.3.0¹ or nRFConnect SDK [1]
-------------------------	---

Proteus-III, Proteus-III-SPI, Setebos-I, Ophelia-III	<ul style="list-style-type: none"> • Using Bluetooth® LE radio of the nRF52840 • Using 1 MBit, 2 MBit or LE-Coded phy • Output power register of the radio chip set to maximum 8 dBm • Using Bluetooth® LE stack Nordic Semiconductor S140 Version 7.0.1¹ or nRFConnect SDK [1]
---	--

 **ANR031 Certification of custom modules**
we-online.com/ANR031

ADDED VALUES

Development Tools

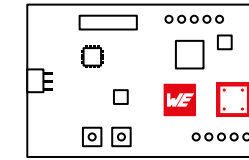

Eval Boards

- Easy testing
- Rapid prototyping
- FTDI integrated (UART to USB)
- All pins available on header
- Current measurement



we-online.com/EVAL-BYOF

AppNotes

 **nRF Connect – developing a custom FW**
we-online.com/ANR030

 **Certification of Custom Modules**
we-online.com/ANR031

INTERNET OF THINGS



191

195

199

206

207

FUNDAMENTALS

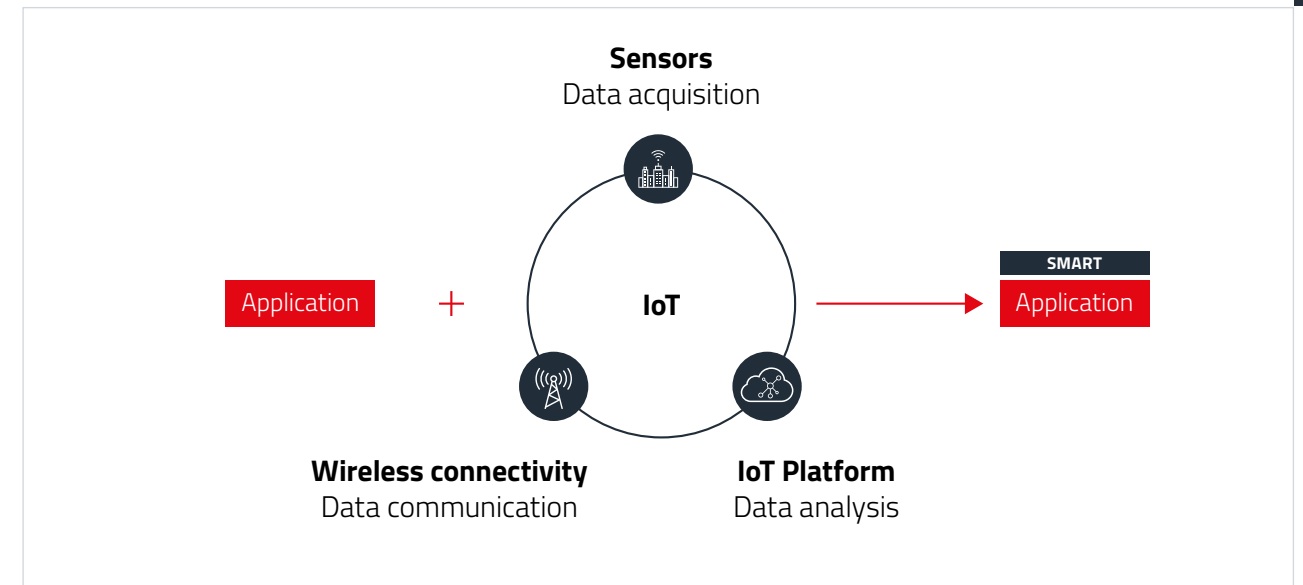







What is IoT ?

The Internet of Things (IoT) can be broadly defined as an umbrella term for a range of technologies that enable devices to connect and interact with each other. Interacting devices and the data they generate, provide for a range of new applications. Industrial automation, healthcare, home automation, smart cities, smart grids and smart farming are some of the areas in which IoT provides substantial benefits.

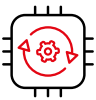
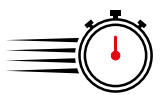
Dubbed the "fourth industrial revolution", Industry 4.0 or also known as M2M, the Industrial IoT (IIoT) is the digitization of industrial assets and processes that connects products, machines, services, locations/sites to workers, managers, suppliers, and partners. Closer networking of the digital world with the world of machines holds the potential for profound changes in global industry and, therefore, for many aspects of private and social life - to the way we work and live.

Why IoT ?

The process of capturing data in the field, transferring the same on to a data platform and further analysis of the same can lead to several benefits such as:

 Process automation	 Resource optimization	 Sustainability	 Higher availability
 Quality control	 Safety and security	 New business models	

ELEMENTS OF AN IOT SYSTEM

An end-to-end IoT solution consists of the following components:

- Sensors and actuators:** This is a part of the system that directly interfaces with the physical environment. Sensors measure the state of the environment and interpret the same as digital data. On the other hand, actuators activate a physical change in the measured environment. Advances in the field of electronics in general and semiconductors in particular has led to the availability of a wide range of sensor and actuators which are highly efficient and yet very compact.
- Wireless connectivity:** Sensors and actuators are typically installed in devices with limited access to the digital world. Consider, for example, a temperature sensor mounted inside an industrial boiler. Wireless connectivity provides in addition to many advantages the reachability necessary for such applications. A wide variety of standard as well proprietary wireless connectivity solutions are available today. Several factors including range, throughput, spectrum regulations, local statutory requirements and power budget determine the choice of wireless connectivity solution. Modern embedded designs usually combine the above components into a single embedded device interacting with a gateway.
- Gateway device:** A gateway device acts as a bridge between the physical and the digital worlds. It interprets the multitude of wireless connectivity protocols, collects the data and forwards the same in a format understood by entities above. In certain applications the gateway device also performs basic analytics like threshold detection.
- Data platform:** This is the platform where the data is finally stored and presented for further analysis. Options here can range from a local database to cloud server with redundancies. The data platform enables the use of technologies like Artificial Intelligence (AI) and Machine Learning (ML) to perform advanced data analytics that generates value additions to the application.
- User application:** This is the interface between the human users and the digital world. Here the status of the observed environment is presented in human readable format. The user can take the necessary actions by interacting with this application.

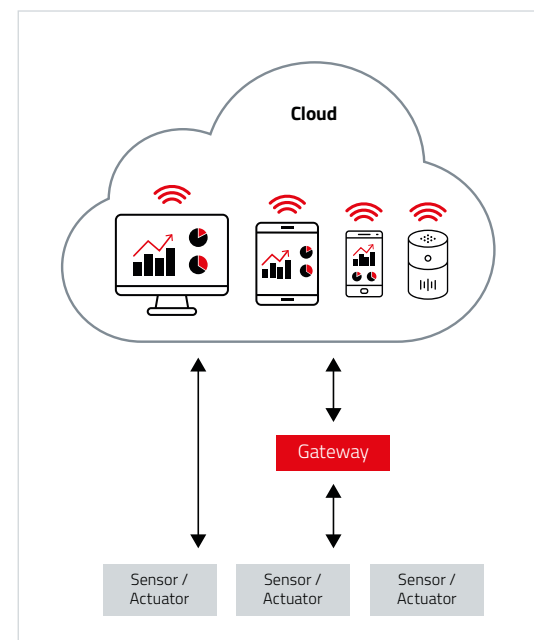
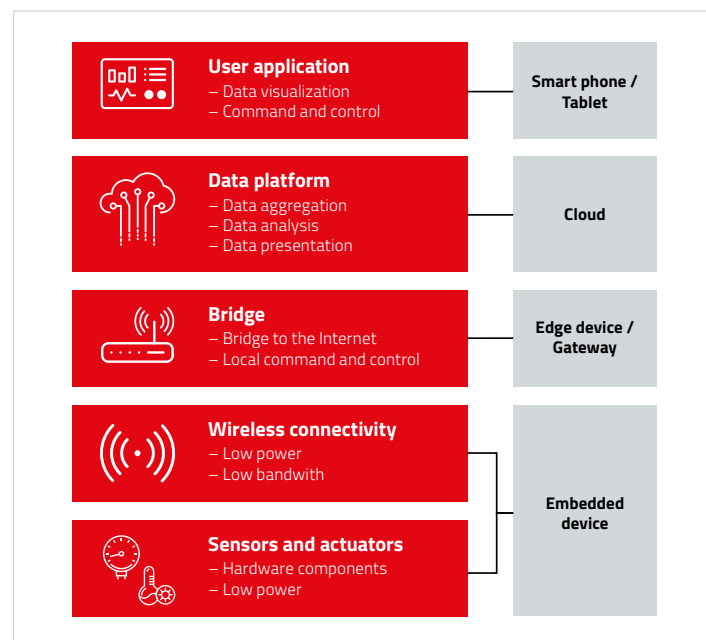

BUILD YOUR OWN IOT APPLICATION

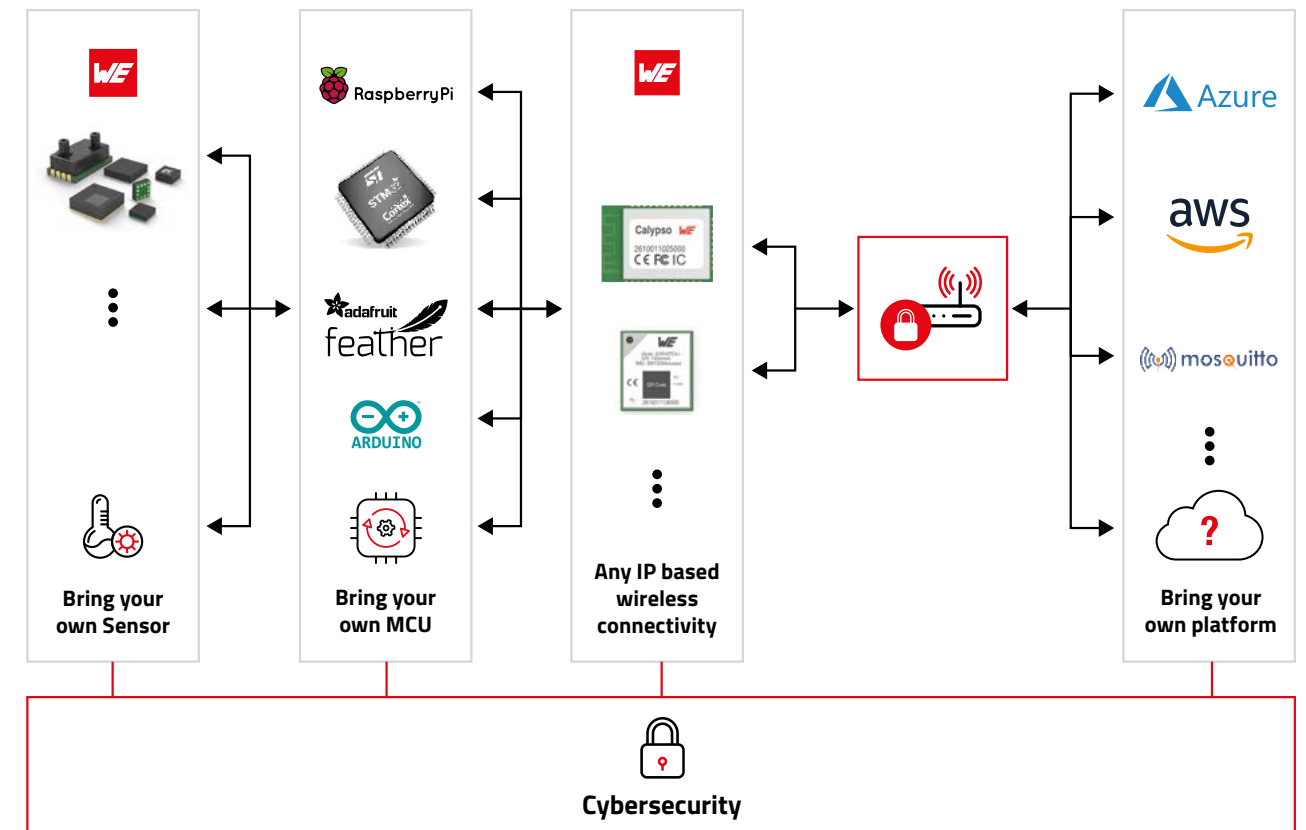

Designing an IoT solution brings with it a number of challenges. Being multifaceted, IoT applications demand a lot of competence from hardware design to UI development. Under such circumstances, it is prudent to take a modular approach. This means breaking down the architecture into functionally independent blocks. Integrating our sensors enables you to monitor the environment accurately. Our radio modules ensure secure connectivity to your cloud platform enabling you to focus on your application and ensuring quicker time-to-market.

IOT CYBERSECURITY REGULATIONS

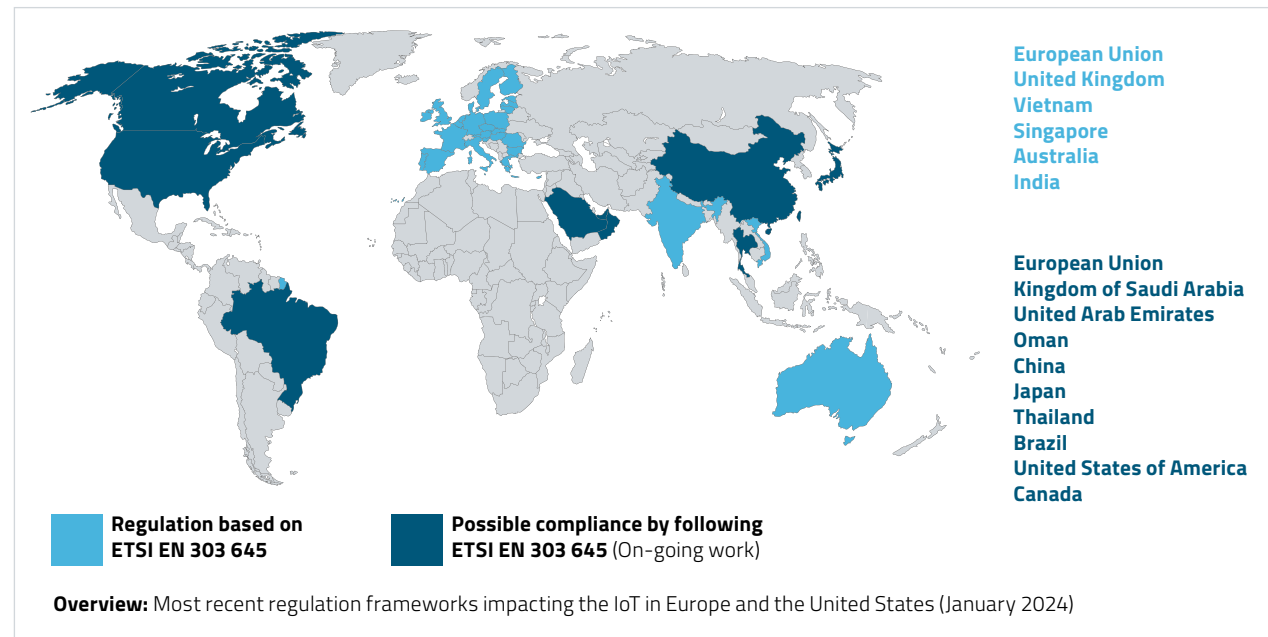

The rapid expansion of IoT technology has been matched by an increased focus on securing these devices against cyber threats. Recent years have witnessed the maturation of the IoT regulatory environment, with lawmakers focusing on two primary objectives:

- Enhancing IoT cybersecurity to make connected devices more resilient against cyber threats.
- Safeguarding personal information privacy within the IoT realm.

Different regulatory frameworks govern various aspects of IoT deployment, from data creation to infrastructure and business operations.

Region	Consumer Data Privacy	Cybersecurity
E.U	The General Data Protection Regulation (EU GDPR Directive 95/46/E.C.) Effective May 25, 2018, it became law in the E.U.and the U.K.	The E.U. Cybersecurity Act Effective June 27 2019, it became law in the European Union and the U.K. The NIS Directive 2 Each E.U. country will have to pass a law in October 2024. The Cyber Resilience Act Proposed to the E.U. Commission in 2022, text validated at the end of 2023, formal approval in the course of 2024RED delegated ActOn 29 October 2021, the European Commission adopted the RED Delegated Act activating Article 3.3 (d), 3.3 (e) and 3.3 (f) for both consumer and professional/ industrial products (C(2021) 7672 1). On 12 January 2022 this supplement to the RED was officially published in the Official Journal of the European Union. RED delegated Act On 29 October 2021, the European Commission adopted the RED Delegated Act activating Article 3.3 (d), 3.3 (e) and 3.3 (f) for both consumer and professional/ industrial products (C(2021) 7672 1). On 12 January 2022 this supplement to the RED was officially published in the Official Journal of the European Union.
U.S.A	There is no comprehensive federal law regulating the collection and use of personal information yet. Specific laws: Healthcare: Health Insurance Portability and Accountability Act Finance: Gramm-Leach-Bliley Ac Government agencies: U.S. Privacy Act of 1974 Children's Online Privacy Protection Act	The IoT Cybersecurity Improvement Act of 2020 , signed by President Trump on December 4 2020. The bill gives NIST, the National Institute of Standards and Technology, the authority to manage IoT cybersecurity risks for devices acquired by the federal government.

RED Delegated Act

On 29 October 2021, the European Commission adopted the RED Delegated Act activating Article 3.3 (d), 3.3 (e) and 3.3 (f) for both consumer and professional/industrial products (C(2021) 7672 1). On 12 January 2022, this supplement to the RED was officially published in the Official Journal of the European Union.

Article 3 of the RED Directive: 2014/53/EU will mandate the following essential requirements regarding cybersecurity:

- (d) Radio equipment does not harm the network or its functioning nor misuses network resources, thereby causing an unacceptable degradation of service;
- (e) Radio equipment incorporates safeguards to ensure that the personal data and privacy of the user and of the subscriber are protected;
- (f) Radio equipment supports certain features ensuring protection from fraud.

By means of this Delegated Act, these three sub articles of the RED are now activated, and the indication is that compliance will become mandatory from the 1st August 2025.

How to go through the compliance process?

For compliance to Article 3.3 of the RED, the directive states the following: 'Where, in assessing the compliance of radio equipment with the essential requirements set out in Article 3(2) and (3), the manufacturer has not applied or has applied only in part harmonized standards the references of which have been published in the Official Journal of the European Union, or where such harmonized standards do not exist, radio equipment shall be submitted with regard to those essential requirements to either of the following procedures: (a) EU-type examination that is followed by the conformity to type based on internal production control set out in Annex III; (b) conformity based on full quality assurance set out in Annex IV.'

This means that there are **two routes** which can be followed in order to be compliant with the articles:

ROUTE 1: Harmonized standards

The first route is via Module A and self-assessment procedure. This route is only possible when there are harmonized standards available and published in the official journal of the EU. At the moment, the CEN/CENELEC is developing three standards (with the goal of these standards eventually becoming harmonized).

ROUTE 2: EU-type examination by a notified body

The second route which can be followed by manufacturers is module B+C, in which an EU-type examination certificate (Module B) will be issued by a Notified Body and the manufacturer must guarantee and declare internal production control (Module C). The notified body choose one of the below mentioned standards based on the application to perform type examination.

Currently available Cybersecurity Standards



ETSI EN 303 645

Contains cybersecurity requirements and procedures for IoT **consumer products**. This not only concerns smart devices themselves, but also sensors and operating parts of these devices and their associated services such as mobile apps, web interfaces etc. The standard consist of 60+ requirements which will investigate, among other things, the protection of personal data, password mechanisms, communication protocols and secure update procedures. The underlying test standard is the ETSI TS 103 701.



IEC 62443-4-2

The IEC 62443 standard is intended to secure **Industrial Automation and Control Systems (IACS)**. It provides a systematic and practical approach that covers every aspect of cybersecurity for industrial systems. There are four series of IEC 62443 standards, aimed at four different IACS categories: General, Policies & procedures, System and Components. The IEC 62443-4-2 has technical security requirements for IACS components and investigates e.g., identification and authentication aspects, user control and resource availability.

IOT CYBERSECURITY BEST PRACTICES

Common Cybersecurity specifications

001101
010100
101101

SOFTWARE

- ✓ No universal default password
- ✓ Ensure that personal data is secure
- ✓ Validate input data



HARDWARE

- ✓ Securely store security parameters and sensitive data
- ✓ Communicate securely
- ✓ Minimize exposed attack surfaces
- ✓ Ensure software integrity



POLICIES

- ✓ Implement a reporting system
- ✓ Keep software updated
- ✓ Examine telemetry data
- ✓ Make it easy to delete user data
- ✓ Make installation and maintenance easy
- ✓ Explain content and purpose of personal data stored

Best practices to implement in any IoT application

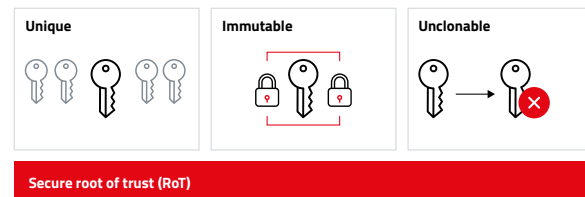

A **secure root** of trust is a unique identity and a cryptographic key associated with it. Since the entire chain of security relies on this root of trust, it is essential to have a RoT that is unique, immutable and unclonable.

Secure boot is a security feature that ensures only trusted software is loaded during the boot process of a device. It is a firmware-based process that verifies the digital signature of the boot loader and any subsequent operating system components before they are loaded into the memory. The goal of secure boot is to prevent malware and other malicious software from executing during the boot process and compromising the system.

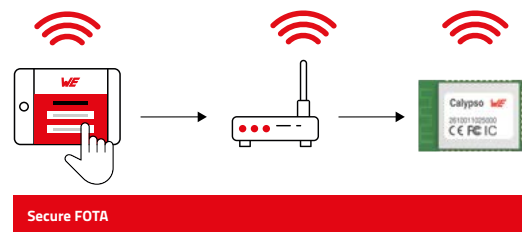
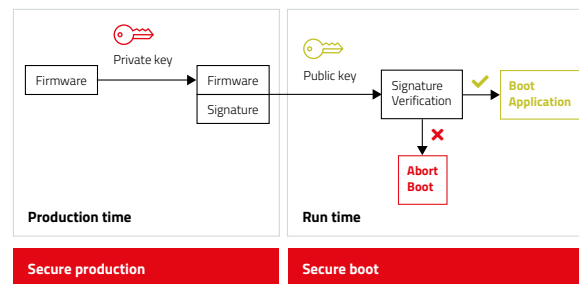

Firmware over-the-air (FOTA) is a process where the firmware of an electronic device is updated wirelessly, typically through a secure connection. FOTA updates can be used to deploy bug fixes, add new features, or patch security vulnerabilities in the device's firmware.

Any interface to the outside world needs to be considered as vulnerable and needs to be secured. A set of standard protocols can be used for **authentication and encryption of communication interfaces**.

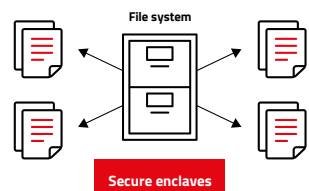

Secure enclaves are isolated execution environments that provide hardware-based security for sensitive data and code. They are designed to protect against attacks that attempt to access or modify data in memory or steal cryptographic keys.

ZERO TOUCH SECURITY IOT CONNECTIVITY

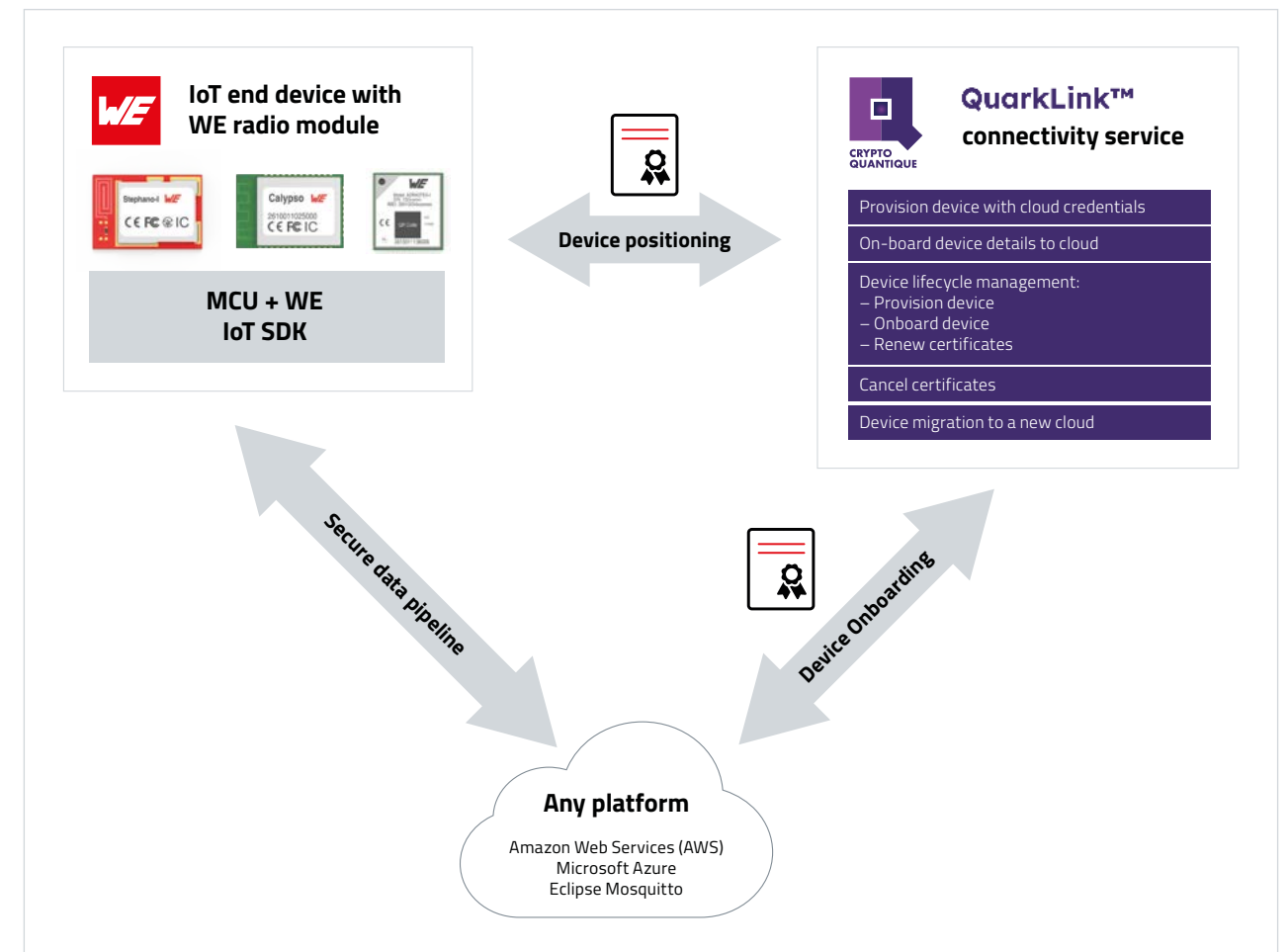

QuarkLink Security Platform from Crypto Quantique

QuarkLink is a software-based IoT security platform from Crypto Quantique that securely connects IoT devices to server-hosted apps on-premises or in the cloud. QuarkLink uses advanced cryptography techniques to integrate with any root-of-trust for end-to-end security across every IoT device.

Crypto Quantique is the first software and IP (Intellectual Property) company to create true end-to-end IoT security products that can be seamlessly integrated throughout the entire supply chain, from supplying security IP to the chip designers to helping OEMs to connect millions of devices to the cloud with our patented software platform.

Partnership Würth Elektronik with Crypto Quantique

Combining Crypto Quantique's QuarkLink security software platform with Würth Elektronik's wireless modules enables automatic and secure connection of thousands of sensor nodes to local or cloud-based servers. The platform allows device provisioning, onboarding, security monitoring, renewal and revocation of certificates and keys, performed with a few keystrokes on a GUI. Users thus have all functions at their disposal required to manage IoT devices in their lifecycle.



WE ADAFRUIT FEATHERWINGS













Würth Elektronik eiSos presents, a range of FeatherWing development boards that are open source and fully compatible with the Feather form factor. Through these development boards WE brings a range of wireless connectivity modules, sensors and power modules to the Feather ecosystem.

Adafruit Feather is a complete line of development boards from Adafruit and other developers that are both standalone and stackable. They're able to be powered by LiPo batteries for on-the-go use or by their micro-

USB plugs for stationary projects. Feathers are flexible, portable, and as light as their namesake.

FeatherWings are stacking boards and add functionality and room for prototyping. At its core, the Adafruit Feather is a complete ecosystem of products - and the best way to get your project flying.

Supercharge your prototyping for easy and fast solution testing.

	<p>Sensor FeatherWing (2501000201291)</p> <ul style="list-style-type: none"> Acceleration sensor (WSEN-ITDS) Absolute Pressure sensor (WSEN-PADS) Temperature sensor (WSEN-TIDS) Humidity sensor (WSEN-HIDS) Sparfun QWIIC connector to enable easy access to hundreds of extension boards 	
	<p>Thyone-I Wireless FeatherWing (2611059021001)</p> <ul style="list-style-type: none"> Proprietary 2.4 GHz RF-Module Connecting wirelessly up to 300 m Microchip ATECC608B secure element for encryption and authentication Connect to Thyone-I modules or USB-Sticks 	
	<p>Adrastea-I FeatherWing (2615039336001)</p> <ul style="list-style-type: none"> Flexible mode selection between LTE-M and NB-IoT 3GPP release 13 compliant Integrated GNSS (supports GPS & GLONASS) Integrated user MCU (ARM Cortex-M4, 1 MB flash memory, 256 KB RAM) Output power class 3 (23 dBm) 	
	<p>Calypso WiFi FeatherWing (2610039025001)</p> <ul style="list-style-type: none"> 2.4 GHz WiFi connectivity Easy connection to Smart Devices Secure data transfer to the cloud UART-to-WiFi bridge 	
	<p>MagI³C Power FeatherWing (2601157100001)</p> <ul style="list-style-type: none"> Input from industrial voltage rails of 9V, 12V, 15V, 18V, 24V or from 5V USB Output 5V and 3.3V to power the Feather system 	
	<p>Connect any Feather Microcontroller</p> <p>Choose any from a range of microcontroller boards from the Adafruit family.</p>	
	<p>Serial Bridge FeatherWing (2601167101001)</p> <ul style="list-style-type: none"> Standard DSUB9 connector 3V3 logic level UART interface on the Feather pin header RS232 with and without flow control Full and half duplex RS485 	

SENSOR FEATHER WING

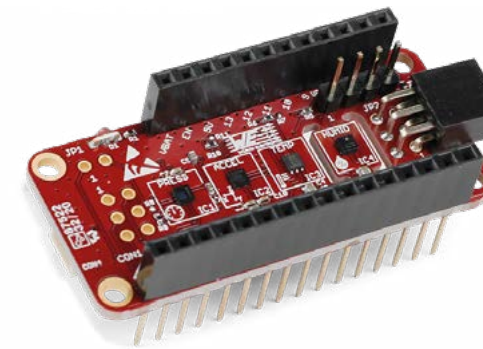

Sensor FeatherWing

2501000201291

Environment and motion sensing



Characteristics



- All the four sensors are connected over the shared I²C bus
- In Adafruit Feather form-factor
- Compatible with QWIIC-connect from Sparkfun

- Easy to expand with our WE FeatherWings and hundreds of already existing boards with the Feather and QWIIC form-factor
- Arduino (C/C++) drivers and code examples available on Github

Applications

- Development of IoT applications
- Rapid prototyping
- Collection of environmental data

ADDED VALUES

- ✓ Hardware design files available for download
- ✓ Drivers in C/C++ for all WE components
- ✓ Examples including source code in C/C++
- ✓ Extensive documentation including step-by-step guides

CALYPSO WIFI FEATHER WING

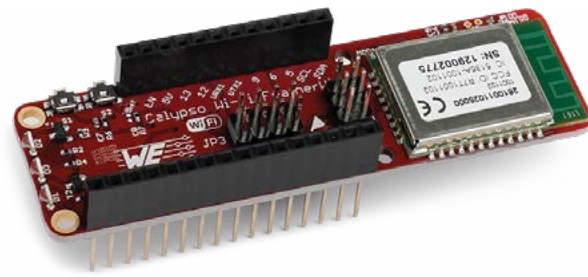

Calypso WiFi FeatherWing

2610039025001

2.4 GHz WiFi Connectivity



Characteristics

- Security and encryption
- Global availability 2.4 GHz licence free band
- Smart antenna selection

- 2.4 GHz IEEE 802.11 b/g/n WiFi Connectivity
- Full TCP/TLS stack with IPv4 and IPv6
- Out-of the box implementation of several commonly used network applications like SNTP, DHPv4, DHCPv6, mDNS, HTTP(S), MQTT
- Direct and secure connection to cloud
- Low power modes for battery operated system
- Secure boot, secure storage and secure connectivity

Applications

- Rapid development of IoT applications
- Easy to use platform for learning, experimenting and prototyping cloud connectivity applications
- Collect sensor data, store it in a database and then visualize the data

App Note



Calypso Cloud Connectivity

we-online.com/ANR023

ADDED VALUES

- ✓ Hardware design files available for download
- ✓ Drivers in C/C++ for all WE components
- ✓ Examples including source code in C/C++
- ✓ Extensive documentation including step-by-step guides

ADRASTEIA-I FEATHERWING-KIT

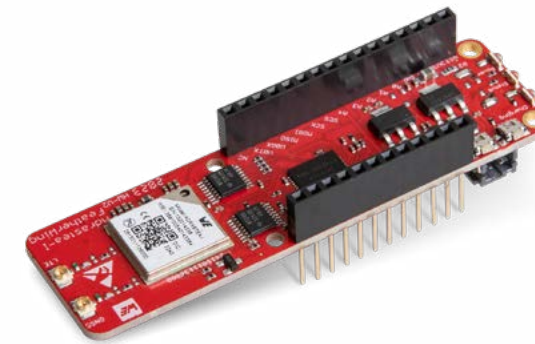

Adrasteia-I FeatherWing-Kit

2615039336001

The FeatherWing-Kit includes one Adrasteia-I FeatherWing-board with the LTE-M / NB-IoT Adrasteia-I module, the external LTE antenna, the external GNSS antenna and USB cable.



Characteristics

- ✓ 3GPP release 13 compliant
- ✓ Integrated GNSS (supports GPS & GLONASS)
- ✓ Output power class 3 (23 dBm)

- Flexible mode selection between LTE-M and NB-IoT
- 3GPP release 13 compliant
- Integrated GNSS (supports GPS & GLONASS)
- Integrated User MCU (ARM Cortex-M4, 1 MB Flash Memory, 256 KB RAM)
- Output power class 3 (23 dBm)
- Supports 3GPP TS27.005, 27.007 and Würth Elektronik enhanced AT commands
- Protocols: IPv4/IPv6, TCP/UDP, HTTP/HTTPS, TLS/DTLS, MQTT, LWM2M
- LTE-Cat.M Supported Bands: B2/B3/B4/B5/B8/B12/B20/B25/B26/B28
- LTE-Cat.NB-IoT Supported Bands: B3/B5/B8/B20/B28
- In Adafruit Feather form-factor
- Easy to expand with our WE FeatherWings and hundreds of already existing boards with the Feather form-factor

Applications

Smart Factory / Industrial 4.0: Predictive Maintenance | Supply Chain Management | Mobile Construction Machines | Vending and Kiosk | Condition Monitoring

Smart City / Smart home: Waste and Water Management | Security and Surveillance | Smart Metering | Traffic and Parking Lighting | Facilities Management

Automotive & Transport: Fleet Management | Asset Tracking | Usage-Based Insurance

Agriculture and Healthcare: Crop & Livestock Monitoring | Irrigation Management | Health Monitoring | Wearables

ADDED VALUES

- ✓ Hardware design files available for download
- ✓ Drivers in C/C++ to simplify implementation of the end application
- ✓ Examples including source code in C/C++
- ✓ Extensive documentation including step-by-step guides

THYONE-I WIRELESS FEATHER WING



Thyone-I Wireless FeatherWing

2611059021001

2.4 GHz Proprietary Wireless connectivity



Characteristics



Long life battery driven application with sleep current = 0.4 μ A



Global availability 2.4 GHz license free band



Mesh



Encryption

- FeatherWing with proprietary 2.4 GHz RF module
- Wireless connection with up to 300 m
- Data Encryption (AES128)
- Integrated security/authentication IC
- Point -to-point connection to Thyone-I module or Thyone-I USB stick

- Mesh network capable
- Low power modes of operation
- In Adafruit Feather form factor

Applications

- Development of IoT applications
- Fast prototyping
- Low power sensor node

ADDED VALUES

- ✓ Hardware design files available for download
- ✓ Drivers in C/C++ for all WE components
- ✓ Examples including source code in C/C++
- ✓ Extensive documentation including step-by-step guides

MAGI³C POWER FEATHER WING

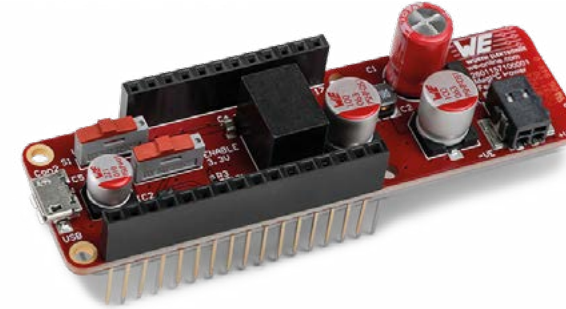

Magi³C Power FeatherWing

2601157101001

Power the Feather stack with any industrial power source



Characteristics

✓ Industrial Input 6 V - 36 V

✓ EN55032 Class B compliant

✓ Internal soft-start

✓ Thermal shutdown

- Operating input voltage of 9 V, 12 V, 15 V, 18 V and 24 V industrial rails
- Maximum 36 V input voltage
- Additional USB connector for 5 V input voltage to select by switch

- Transformation of industrial input voltage to 5 V
- Transformation of 5 V to 3.3 V
- Enable functionality and mode selection available to control and tune performance of Magi³C MicroModule

Applications

Supply the FeatherWing system with power from industrial power sources.

ADDED VALUES

- ✓ Hardware design files available for download
- ✓ Extensive documentation including step-by-step guides

SERIAL BRIDGE FEATHERWING

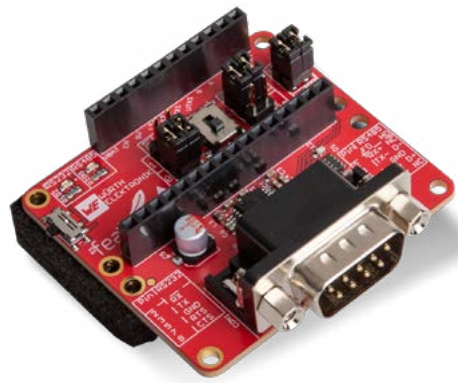

Serial Bridge FeatherWing

RS232/485
2615039336001

Easy to expand with our WE FeatherWings and hundreds of already existing boards with the Feather form-factor



Characteristics



- Standard DSUB9 connector
- 3V3 logic level UART interface on the Feather pin header
- RS232 with and without flow control
- Full and half duplex RS485
- Double throw slider to switch between RS232 and RS485
- In Adafruit Feather form-factor
- Easy to expand with our WE FeatherWings and hundreds of already existing boards with the Feather form-factor

Applications

- Retrofitting: Connect legacy RS232/RS485 devices wirelessly to the Internet
- Easy to use platform for learning, experimenting and prototyping cloud connectivity applications

ADDED VALUES

- ✓ Hardware design files available for download
- ✓ Examples including source code in C/C++
- ✓ Extensive documentation including step-by-step guides

FEATHERWINGS APPLICATION EXAMPLES

EXAMPLE 1: Built up a Proprietary Network

- Select a microprocessor of your choice from the Adafruit Feather ecosystem
- Use the Sensor FeatherWing for measuring condition parameters like temperature, air pressure, humidity and acceleration
- Send data with the Thyone-I FeatherWing on 2.4 GHz proprietary radio
- Thyone-I USB radio stick or another Thyone-I FeatherWing can receive the data and you get access to all information
- Even various tags could be connected wirelessly
- We support you with libraries and examples available on Github for some microcontrollers

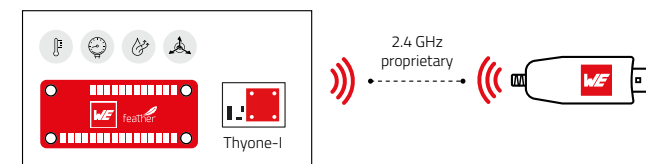

EXAMPLE 2: Connect with WiFi

- Select a microprocessor of your choice from the Adafruit Feather ecosystem
- Use the Sensor FeatherWing for measuring condition parameters like temperature, air pressure, humidity and acceleration
- Send out data with the Calypso FeatherWing on 2.4 GHz WiFi
- Receive data on smart devices or server structures

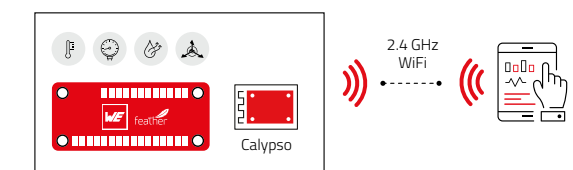

EXAMPLE 3: Sensor to Cloud

Another simple application example is described here with the combination of an Adafruit Feather M0 Express with our Sensor FeatherWing and Calypso WiFi FeatherWing.

A typical IoT application consists of sensing the environment through sensors, collecting the sensor data and forwarding it to a cloud. The cloud platform then provides options for further processing and visualization of the data. In this example, the data is read from the sensors of the Sensor FeatherWing and forwarded to a cloud platform via the Calypso WiFi FeatherWing.

Currently, the data can be sent to one of the following cloud platforms: **Microsoft Azure** and **Amazon AWS**. Sample code and further documentation can be found on our Sensor2CloudConnectivity Github page.

4 sensors to measure environmental data:

- Temperature
- Humidity
- Acceleration
- Absolute Pressure

An Adafruit Feather M0 acts as managing director.

The Calypso WiFi FeatherWing collects the sensor data and passes it on to any cloud.

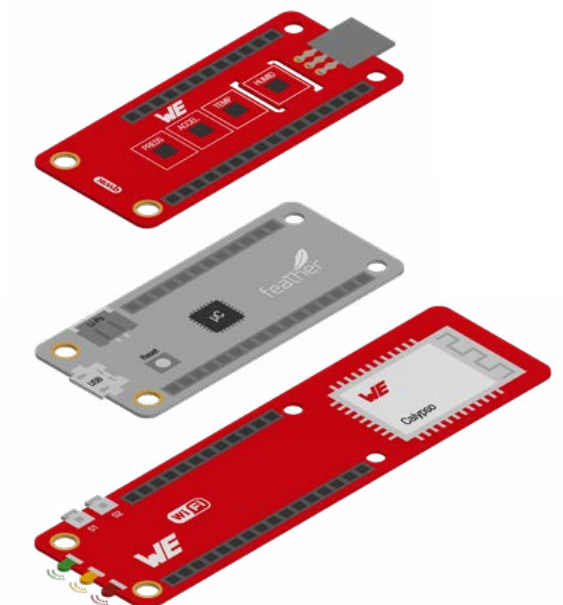

GitHub

FeatherWings:
www.github.com/WurthElektronik/FeatherWings



PRODUCTS



Calypso IoT Design Kit New

2610059035001

IoT Plug-and-Play! IoT connectivity simplified.



Characteristics

- Fast evaluation
- Full flexibility
- Adaptable application

- Design Kit for prototyping Sensor-to-Cloud IoT applications
- Monitor temperature, absolute pressure, relative humidity and 3-axis acceleration
- Plug-and-Play secure connectivity to Azure IoT central
- Design Kit in Adafruit Feather formfactor
- Easy to expand with our WE FeatherWings and hundreds of already existing boards with the Feather form factor
- Arduino (C/C++) drivers and code examples available on GitHub



Working principle

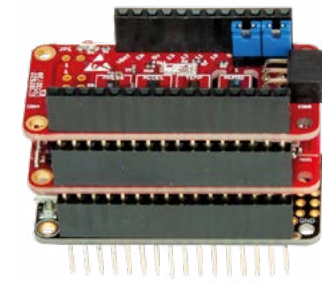
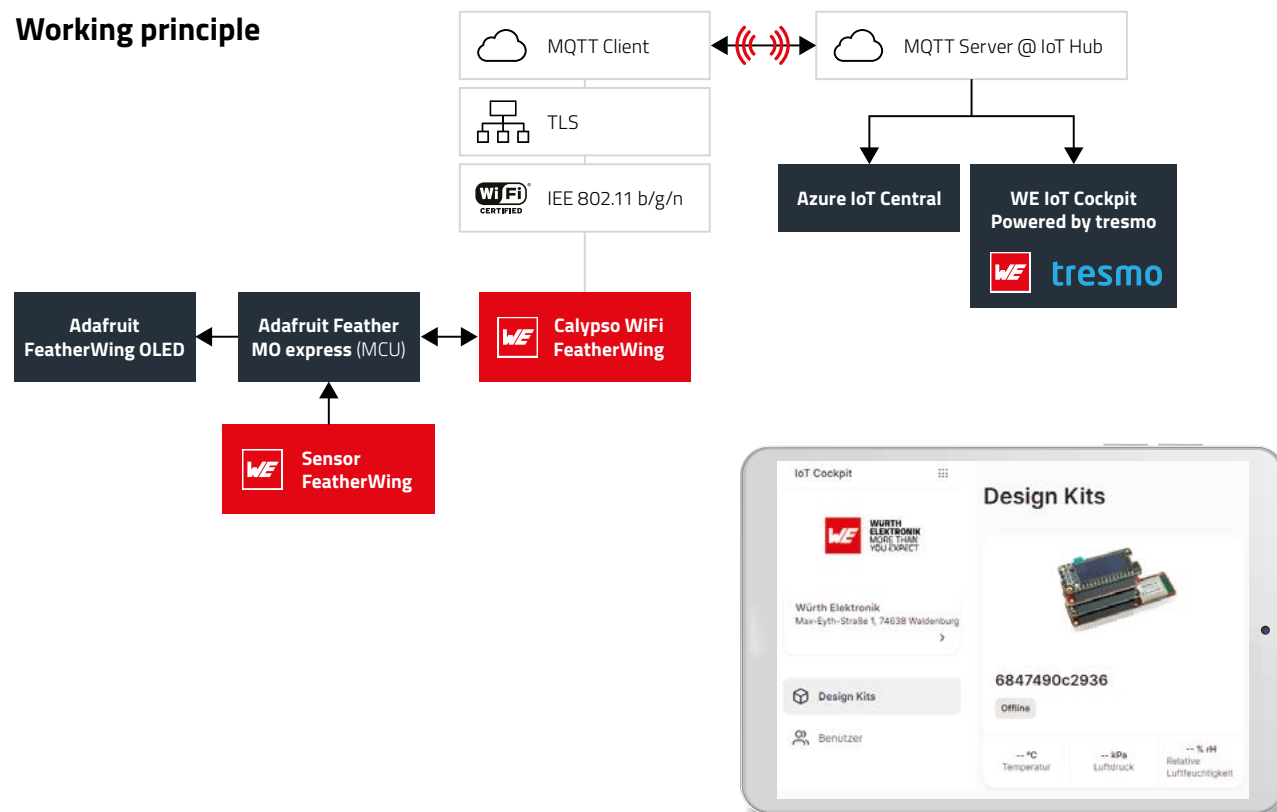

SensorBLE FeatherWing Kit New

2611187024001

IoT Plug-and-Play! IoT connectivity simplified.



Characteristics

- Ready to use app
- Fast evaluation
- Full flexibility
- Adaptable application

- Monitor temperature, absolute pressure, relative humidity and 3-axis acceleration
- Universal connectivity to any smart device using Bluetooth® LE 5.1
- WE-SensorBLE app for data visualization on Android and iOS
- Open Source Microcontroller Firmware
- Open Source APP source code



Working principle

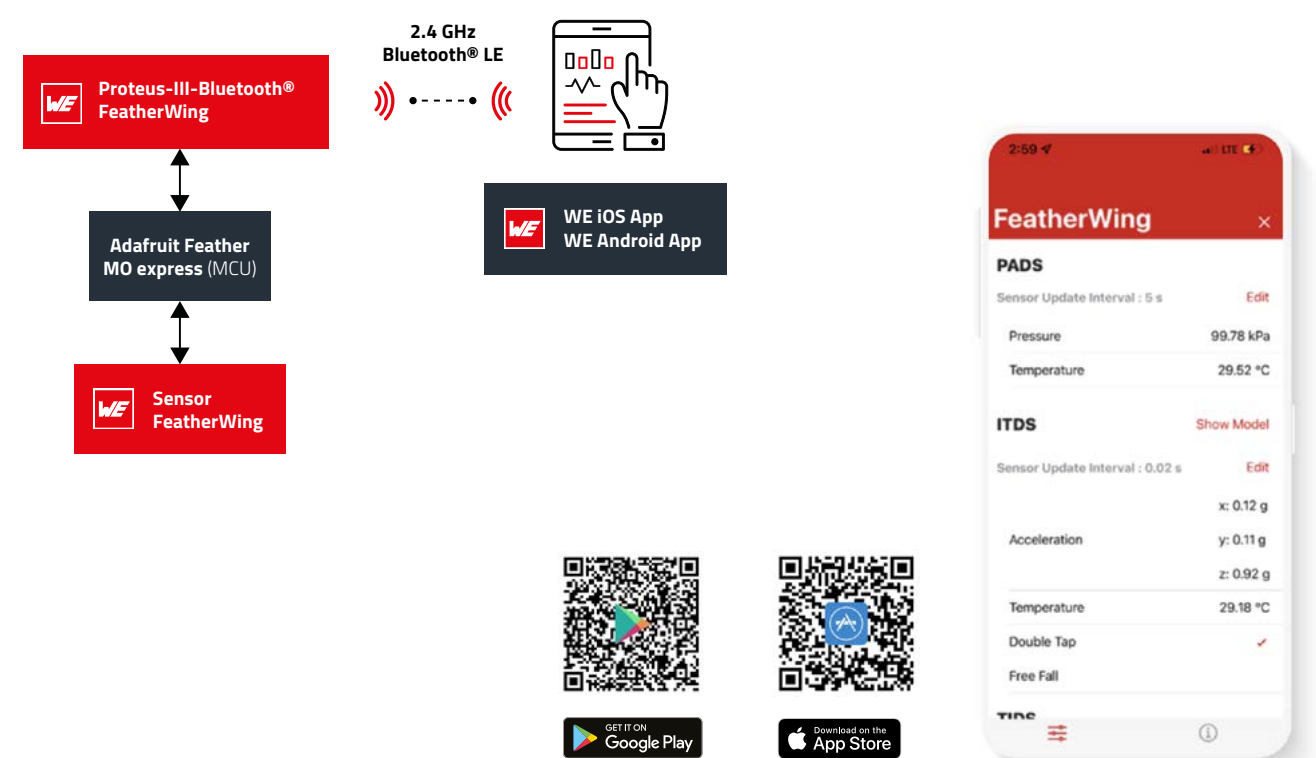

WELCOME TO CREATING IDEAS!

You can explore some inspiring ideas that will help you unleash your creativity and come up with innovative solutions.

These Ideas are clustered in six focus markets: Industry, Mobility, Automation & Smart Home, Energy, Consumer and Medical. On the right, there is an overview about all stories that want to inspire you. Or you can simply browse through the following pages.

We wish you lots of fun and inspiration.
Your Würth Elektronik Wireless Connectivity team



Share your idea with us:
wcs@we-online.com



REPLACING LCD DISPLAYS	SMART FARMING	IOT-WASHING MACHINE			
REPLACING SWITCHES	INTELLIGENT IRRIGATION	INTELLIGENT COFFEE MACHINE	SMART METERING		
DIGITAL DEVICES	URBAN ELECTRO BIKES	VANDALISM PROTECTION	SMART SPORT EQUIPMENT	ADAPTIVE SOLAR ENERGY	DIGITAL HEALTH & PREVENTION
POWER TOOLS	CHARGING INFRA-STRUCTURE	PESTICIDE MONITORING	INTELLIGENT HOUSE-KEEPING	INVERTER MONITORING	MEDICAL EVERYDAY OBJECTS
Industry	Mobility	Automation & Smart Home	Consumer	Energy	Medical
CONSTRUCTION LIGHTING	AUTOMATED GUIDED VEHICLES	KEYLESS ENTRY	SMART HELMET	TIME SYNCHRONIZED SAFETY LIGHTING	LIVESTOCK MONITORING
AIR FILTERS	PEDESTRIANS & TRAFFIC SAFETY	CONNECTED LIGHTING	BATTERY MONITORING	ENERGY & UTILITIES	MEDICAL MILL
CONTAINER TRACKING		WIRELESS ALARM SYSTEM			
WEIGHTING SYSTEM					

MOBILE CONNECTIVITY – REPLACING LC DISPLAYS

LCDs are often used to indicate the status of devices, machines, and factory equipment. A little LCD Monitor on a machine looks elegant but it is not necessarily a sensible solution. LCDs age faster under harsh conditions and are wasteful in applications where they only need to be read a few times a year. Better: wireless data retrieval.

Anyone who provides machines or industrial plants with Liquid Crystal Displays should always consider whether such a display is necessary at this point, especially because every person who comes to the machine today carries a device with much higher display quality. With the industrial grade Bluetooth, WiFi and cellular modules from Würth Elektronik, it is easy to replace LC displays and output information to a mobile device app instead.

Benefits

Use your phone to check the machine

- ✓ Access is possible from anywhere, and system updates can be transmitted easily online by the manufacturer.
- ✓ Access to the data can be ensured via NFC or LE authentication.
- ✓ The use of cost-intensive displays can be avoided.

REPLACING LC DISPLAYS

BLUETOOTH 



Proteus-III

- Bluetooth® LE 5.1
- Nordic nRF52840
- 8 dBm output power
- 12 x 8 x 2 mm

Make use of the screen from a mobile device while saving the cost of an integrated LC display in the machine.



WIFI 



Calypso

- IEEE 802.11 b/g/n, 2.4 GHz
- +18 dBm output power
- 19 x 27.5 x 4 mm

Using the WiFi direct function to use a responsive website instead of Bluetooth.



COMBINED  



Stephano-I:

- Bluetooth® LE 5, WiFi
- 13 dBm output power
- 13 x 9.5 x 2 mm

Possibility to connect via WiFi to the internet and via Bluetooth® to end users smart devices.

CELLULAR  



Adrastea-I

- LTE-NB.IoT / Cat.M1
- incl. GNSS
- 14 x 13 x 2 mm

Connect an off-site machine to the internet through a cellular network. Save the LC display cost and lower the amount of possible damageable components.

CREATE DATA



Serial Bridge FeatherWing

- Standard DSUB9 connector
- 3V3 logic level UART interface on the Feather pin header
- RS232 with and without flow control
- Full and half duplex RS485

Sensing environmental conditions like temperature and potting soil humidity

SEND DATA 



Calypso WiFi FeatherWing

- WiFi-Connection 2.4 GHz
- Easy connection to Smart Devices
- Sending data to the server
- Handling multiple sensor nodes

Sending the collected data from the sensors into the cloud platform



REPLACING SWITCHES

MOBILE CONNECTIVITY – REPLACING “OLD FASHIONED” SWITCHES

Rotary switches on control units were a sensible solution for a long time. Furthermore, there was always the risk of unauthorized use. The more modern and secure approach: make the control unit addressable via radio. Or even make it an IoT device.

The ubiquity of smartphones and the widespread use of WiFi networks open up the possibility of dispensing with rarely used switches on control units. With the slim Bluetooth LE and WiFi modules from Würth Elektronik, you can make your control unit capable of wireless communication. The big advantage: Access can be restricted by secure authentication. And where a connection already exists, it can also be used to update the control unit, or for management via the Internet.

Benefits

Use your phone to activate the switch

- ✓ Avoid external changes of the control unit.
- ✓ Authentication necessary for changes.
- ✓ Mobile device can update the control unit's main functions.
- ✓ WiFi: Cloud connectivity for status information, changes of settings from anywhere in the world etc..

BLUETOOTH 



Proteus-III

- Bluetooth® LE 5.1
- Nordic nRF52840
- 8 dBm output power
- 12 x 8 x 2 mm

Replace the rotary switches with BT-LE and connect to Mobile device. Avoid external changes to the control unit. Advantages like Authentication needed for changes. Mobile device can update control unit main functions.

WIFI 



Calypso

- IEEE 802.11 b/g/n, 2.4 GHz
- +18 dBm output power
- 19 x 27.5 x 4 mm

Connect the control unit to Internet. Cloud connectivity for status informations, changes to the settings from anywhere in the world etc.

CREATE DATA



Serial Bridge FeatherWing

- Standard DSUB9 connector
- 3V3 logic level UART interface on the Feather pin header
- RS232 with and without flow control
- Full and half duplex RS485

Sensing environmental conditions like temperature and potting soil humidity

SEND DATA 



Calypso WiFi FeatherWing

- WiFi-Connection 2.4 GHz
- Easy connection to Smart Devices
- Sending data to the server
- Handling multiple sensor nodes

Sending the collected data from the sensors into the cloud platform





DIGITAL DEVICES

POWER TOOLS IOT CONNECTIVITY FOR MONITORING USAGE

Professional digital devices have to perform at high levels and must be able to endure a tough workload. The Industrial Internet of Things enables better management of expensive tools via wireless communication. In conjunction with sensors that monitor appropriate use, new business areas, such as the leasing of equipment, are opening up.

The slim and energy-saving WiFi and Bluetooth modules from Würth Elektronik make power tools capable of communicating. The devices can be linked up anywhere - in the workshop, in the vehicle, or on the construction site. In conjunction with temperature, humidity and motion sensors, the tools become smart. They can transfer data concerning usage and wear to a cloud application for instance. The advantage: maintenance cycles can optimally be scheduled, and rental equipment can be billed based on actual usage. Furthermore, inappropriate use or damage can additionally be detected with the help of sensors.

Benefits

Power tools capture data concerning the usage and share it wirelessly

- ✓ Access to device data at any time.
- ✓ Wireless data access prevents penetration of dust and water.
- ✓ Opportunity to install further systems, e.g. for localization of tools or sensors for drop detection.
- ✓ Data can be extracted, e.g. via a mobile app.

ACCELERATION 



WSEN-ITDS

- 3 axis acceleration
- 14 bit output resolution
- ±2g, ±4g, ±8g, ±16g
- 2 x 2 x 0.7 mm

Sensing Acceleration for vandalism protection.

BLUETOOTH 



Proteus-III

- Bluetooth® LE 5.1
- Nordic nRF52840
- 8 dBm output power
- 12 x 8 x 2 mm

Connection between the tools, which want to be used in Sync mode: Sync mode one master tool controls the other(s). Meaning, activating this tool via the tool trigger will activate the synchronized tool(s) as well.

HUMIDITY & TEMPERATURE 

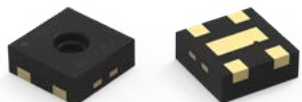

WSEN-HIDS

- 16 bit humidity and temperature output
- I²C interface
- 1.5 x 1.5 x 0.5 mm

Sensing Humidity & temperature of the environment to ensure the vacuum cleaner is used in right operating conditions.

WIFI 



Calypso

- IEEE 802.11 b/g/n, 2.4 GHz
- +18 dBm output power
- 19 x 27.5 x 4 mm

Connect the control unit to Internet: Cloud connectivity for status informations, changes to the settings from anywhere in the world.

CELLULAR 



Adrastea-I

- LTE-NB.IoT / Cat.M1
- incl. GNSS
- 14 x 13 x 2 mm

Connect the control unit to Internet: Cloud connectivity for status informations, changes to the settings from anywhere in the world etc.

COMBINED 



Stephano-I:

- Bluetooth® LE 5, WiFi
- ESP32-C3
- 13 dBm output power
- 13 x 9.5 x 2 mm

Possibility to connect devices directly to the internet via WiFi and to smart devices via Bluetooth®.



SMART INDUSTRY – CONNECTED POWER TOOLS

The interconnection of power tools offers various advantages and applications. Especially with battery-powered tools, there is no longer a connection between the tools, which does not allow a synchronized function.

With the help of Bluetooth networking, the various tools can be operated in coordination with each other. For example, a vacuum cleaner starts as soon as the drill is started. Ideally, the various functions can be controlled with the help of an app.

Via a mobile device, it is possible to download the usage and wear data, and as a result to optimally plan the maintenance cycles or, in the case of a rental device, to settle the accounts on the basis of actual usage.

Benefits

- ✓ Access to device data at any time.
- ✓ Contactless data access prevents the penetration of dust and water, extending device life.
- ✓ Installation of further systems, e.g. for localizing the location of the molds or sensors with fall detection. This data can be read out using a mobile app.

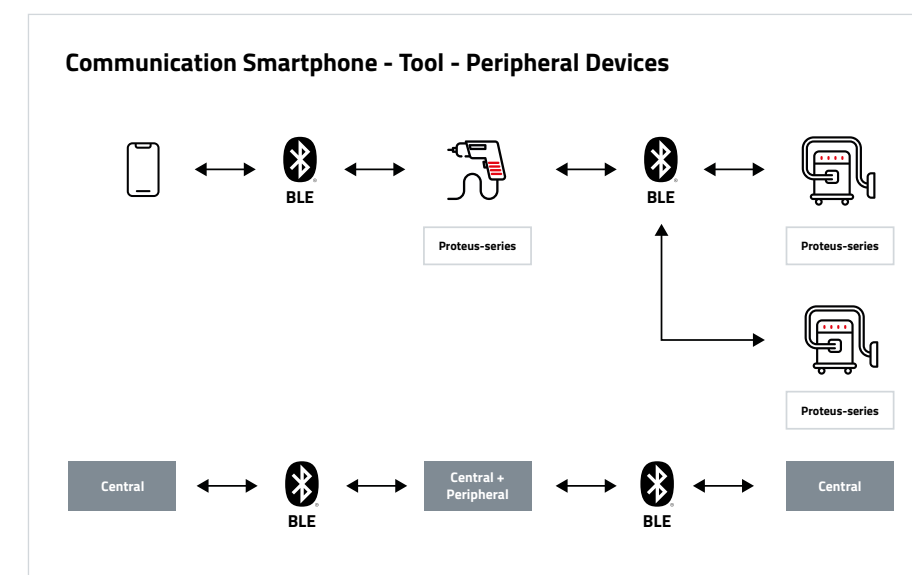
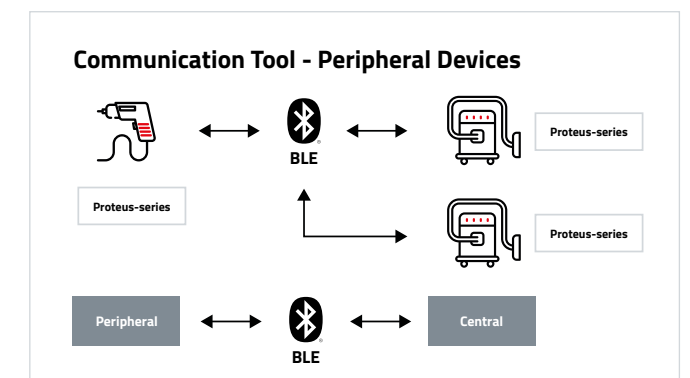
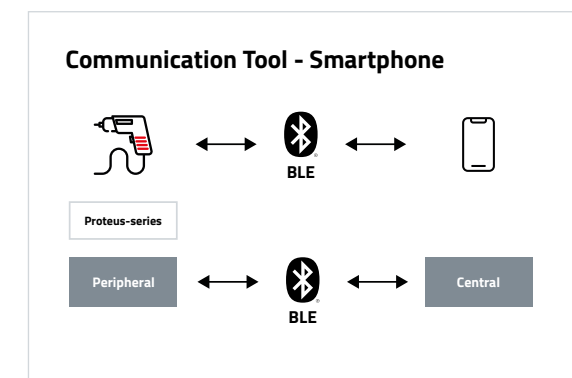

HUMIDITY & TEMPERATURE

WSEN-HIDS

- 16 bit humidity and temperature output
- I²C interface
- 1.5 x 1.5 x 0.5 mm

Sensing Humidity & temperature of the environment to ensure the vacuum cleaner is used in right operating conditions.

ACCELERATION

WSEN-ITDS

- 3 axis acceleration
- 14 bit output resolution
- ±2g, ±4g, ±8g, ±16g
- 2 x 2 x 0.7 mm

Sensing Acceleration for vandalsim protection.

BLUETOOTH

Proteus-III

- Bluetooth® LE 5.1
- Nordic nRF52840
- 8 dBm output power
- 12 x 8 x 2 mm

Connection between the tools, which want to be used in Sync mode: Sync mode one master tool controls the other(s). Meaning, activating this tool via the tool trigger will activate the synchronized tool(s) as well.



CONSTRUCTION LIGHTING

SMART INDUSTRY – INTELLIGENT MOBILE CONSTRUCTION LIGHTING

Mobile lighting at construction sites, especially on expressways, pose a great risk to the workers, if these lights are shifted by unobservant road users. Sensors and a communication mesh provide additional safety.

The lamps and warning beacons for road construction have sensors for detecting strong movement impulses (impact) as well as for location detection. The lamps are interconnected via a mesh network and report any change in location within a centimeter range. This eliminates the need for regular checks along the site to ensure that all luminaires are still in the right position. The interconnection of the luminaires can be realized with a Wirepas Massive Routing Mesh, or WE-ProWare Flooding Mesh by Würth Elektronik.

Benefits

Smart lamps form a mesh and control their own position

- ✓ Luminaires equipped with GNSS and acceleration sensors report any change in location.
- ✓ Further advantages are the constant control of all functions, such as battery charge level, set brightness, or even environmental factors, e.g. temperature and humidity.



Central Master Gateway

The Central Master Gateway is equipped with WSEN-HIDS, WSEN-ITDS sensors, Thetis-I and Adrastea-I module.

HUMIDITY & TEMPERATURE

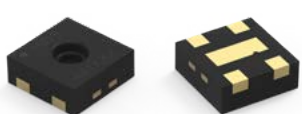

WSEN-HIDS

- 16 bit humidity and temperature output
- I²C interface
- 1.5 x 1.5 x 0.5 mm

Sensing Humidity & Temperature to be aware of true local weather conditions.

CELLULAR & POSITIONING



Adrastea-I

- LTE-NB.IoT / Cat.M1
- incl. GNSS
- 14 x 13 x 2 mm

Communication from Master Gateway at construction site to central server and getting location through GNSS Service.

LONG-RANGE-WAN

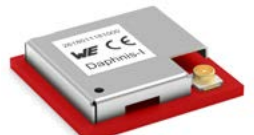

Daphnis-I

- 868 MHz
- Supported long-range-WAN Classes A, B and C
- 15 x 16 x 3 mm

Connection of dozens or hundreds of devices over long distance.

ACCELERATION



WSEN-ITDS

- 3 axis acceleration
- 14 bit output resolution
- ±2g, ±4g, ±8g, ±16g
- 2 x 2 x 0.7 mm

Impact or location movement detection.

MESH



Thetis-I

- Wirepas routing mesh protocol, 2.4 GHz
- +6 dBm output power
- 8 x 12 x 2 mm

Connecting hundreds of devices to extend the range and without having the need to add LTE with recurring costs to each device

PROPRIETARY



Thyone-I

- 2.4 GHz
- Smart antenna selection
- 8 dBm output power
- 12 x 8 x 2 mm

Use a remote control connected wirelessly to the lamps and adjust settings.

CONNECTIVITY – AIR FILTERS

Equipping public buildings such as schools with air filtration devices to prevent infection, has burdened facility managers with an additional maintenance task. Manufacturers of such equipment would do well to simplify maintenance and operation – only a properly working air filter will protect.

The more air filters are in use, the more important remote maintenance becomes. Differential pressure and humidity sensors can be used to monitor the status of the filters. An internet gateway and a cloud application make remote maintenance convenient. WiFi modules can be integrated to connect the devices to the gateway. A particularly flexible solution is an 868 MHz radio module with the proprietary radio protocol WE-ProWare. Additionally, this allows the bridging of longer distances than with WiFi, if necessary.

Benefits

Proprietary network for remote maintenance

- ✓ WE-ProWare offers the possibility to customize functions by using simple commands.
- ✓ Unlike other sub-GHz standards, there are no license fees involved.

AIR FILTERS



WiFi 



Calypso

- IEEE 802.11 b/g/n, 2.4 GHz
- +18 dBm output power
- 19 x 27.5 x 4 mm

Using the WiFi direct function to use a responsive website instead of Bluetooth or simply connect the filter directly to the internet.

PROPRIETARY 

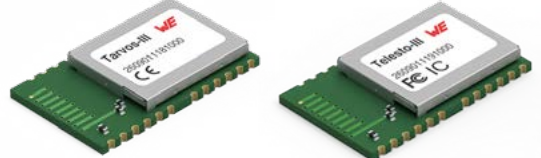

Tarvos-III **Telesto-III**

- 868 MHz
- RF Pad / PCB Antenna
- 14 dBm output power
- 27 x 17 x 3.8 mm

- 915 MHz
- RF Pad / PCB Antenna
- 14 dBm output power
- 27 x 17 x 3.8 mm

Connecting several Air filter in large building with each other through a mesh network. Sub GHz because of LongRange and sending data through walls.

LONG-RANGE-WAN



Daphnis-I

- 868 MHz
- Supported long-range-WAN Classes A, B and C
- 15 x 16 x 3 mm

Connecting dozens of devices to a gateway.

HUMIDITY & TEMPERATURE 

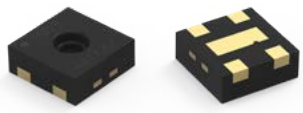

WSEN-HIDS

- 16 bit humidity and temperature output
- I²C interface
- 1.5 x 1.5 x 0.5 mm

Sensing Room temperature & Humidity.

ACCELERATION 

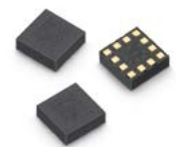

WSEN-ITDS

- 3 axis acceleration
- 14 bit output resolution
- ±2g, ±4g, ±8g, ±16g
- 2 x 2 x 0.7 mm

Sensing Acceleration for vandalism protection, e.g. tamper detection.

DIFFERENTIAL PRESSURE 



WSEN-PDUS

- 15 bit digital output
- Analog & I²C interface
- 13.3 x 8 x 7.55 mm

Measuring the pre- and post-pressure of a filter to detect filter contamination.

CONTAINER TRACKING

SMART INDUSTRY - CONTAINER TRACKING

Even during the pandemic, there were more than 150 Million containers shipped during 2021. It has never been as important to know, where your containers are, as it is at the moment! Due to shortages of materials, the bottle necks on asian harbors and during an pandemic, it is crucial to be aware of what happens with your products and where they are.

With the Wirepas Mesh Network communication protocol every device can be used as wireless router and can act as a repeater for other nodes. With WE sensors it's possible to monitor the environmental conditions of your parts just in time, any time. The GNSS modules allow to follow the tracked container and give you an exact location of your parts.

A network out of thousands of nodes, i.e. containers, increases the scale of the whole network and following the distance to bridge. Wirepas Massive offers a so called Positioning engine which is helpful to locate containers even inhouse.

Benefits

- ✓ Localization with GNSS
- ✓ Monitor the conditions with environmental sensors
- ✓ Build up a mesh Network with wirepas modules



MESH 



Thetis-I

- Wirepas routing mesh protocol, 2.4 GHz
- +6 dBm output power
- 8 x 12 x 2 mm

Building a huge network of sensor nodes with a robust wireless Mesh.

HUMIDITY & TEMPERATURE 

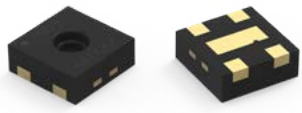

WSEN-HIDS

- 16 bit humidity and temperature output
- I²C interface
- 1.5 x 1.5 x 0.5 mm

Measuring container internal or outdoor temperature and humidity.

CELLULAR & POSITIONING 



Adrastea-I

- LTE-NB.IoT / Cat.M1
- incl. GNSS
- 14 x 13 x 2 mm

Connecting the container tracking to the cellular network and the location can be tracked wherever the container is on the globe.

ACCELERATION 



WSEN-ITDS

- 3 axis acceleration
- 14 bit output resolution
- ±2g, ±4g, ±8g, ±16g
- 2 x 2 x 0.7 mm

Sensing Acceleration and impacts to have the information available when a container starts moving or in case a huge damage to the load has occurred.

LONG-RANGE-WAN

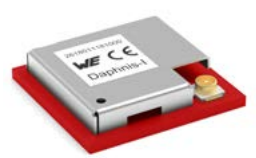

Daphnis-I

- 868 MHz
- Supported long-range-WAN Classes A, B and C
- 15 x 16 x 3 mm

Connecting hundreds of devices to a gateway.



WEIGHTING SYSTEM



CONNECTIVITY – WIRELESS WHEELS WEIGHTING SYSTEM

Agriculture, biogas plants, haulers and industrial enterprises - there are many areas of application for a mobile axle load scale. When driving over it, the load on each single wheel of the vehicle is weighed separately. The measured values must then be merged.

In the case of mobile axle load scales, the weighing program calculates the total weight via the weighed axles. For this purpose, the individual scales must be linked by radio. Using a mesh network between the scales, the data can be collected and sent to a mobile device. Software in an mobile App can calculate the center of gravity of the load. Connecting the networked scales to the Internet and equipping them with GPS modules makes the management of the stock of these devices as simple as possible.

Benefits

Mesh-network of wheel scales

- ✓ WE-ProWare is ideal for individual mesh-networks of devices.
- ✓ Localization of scales and Internet-based management facilitates leasing business models.

WiFi 



Calypso

- IEEE 802.11 b/g/n, 2.4 GHz
- +18 dBm output power
- 19 x 27.5 x 4 mm

Connecting the scale gateway to the Internet.

COMBINED  



Setebos-I

- Bluetooth® LE 5.1 & WE-ProWare 2.4 GHz
- 8 dBm output power
- 12 x 8 x 2 mm

Mobile App Connectivit Sending weight data through mobile App. Mesh between 4 scales for each wheel.



Stephano-I:

- Bluetooth® LE 5, WiFi
- 13 dBm output power
- 13 x 9.5 x 2 mm

WiFi and Bluetooth® connectivity for internet connection and controlling application via Bluetooth®.

ACCELERATION 



WSEN-ITDS

- 3 axis acceleration
- 14 bit output resolution
- ±2g, ±4g, ±8g, ±16g
- 2 x 2 x 0.7 mm

Sensing Acceleration for vandalism protection or to avoid theft.



E-MOBILITY



URBAN ELECTRO BIKES

In a sustainable world where e-mobility becomes more and more important and dominant, added services through connectivity solutions are crucial to differentiate from others.

Easy usage of an e-bike for any user – if it is your personal or a rental bike – can be simply ensured using technologies like LTE, Bluetooth & GNSS.

Instead of an attached fixed display, the control is simply done via smartphone. A Bluetooth Connect app is the smart Control Center and so the smartphone clearly displays the navigation and bike status and control even in daylight. Electronic locking can be performed and the cyclist can access diagnostics and support information for the bike. Once the settings are made, the engine automatically remembers the last rides settings.

It allows you to safely and freely explore the new road.

Thanks to a constant LTE connection, GPS tracking allows constant monitoring of the e-bike's position. Even in the worst case of theft, users around the world can be helped to get their beloved e-bike back.

Benefits

- ✓ Real-time location, route tracking, theft warning, navigation
- ✓ (Battery)Status of the vehicle / e-bike at any time
- ✓ Flexibility of the display /cost saving for bike manufacturer
- ✓ Being able to offer more than just a bike
- ✓ Creating a possible business model of recurring business

CELLULAR & POSITIONING

Adrastea-I

- LTE-NB.IoT / Cat.M1
- incl. GNSS
- 14 x 13 x 2 mm

Access to all data (service and status Information) from anywhere in the world added by Live Tracking Signal of the e-bike / vehicle across the globe.

COMBINED

Setebos-I

- Bluetooth® LE 5.1 & WE-ProWare 2.4 GHz
- 8 dBm output power
- 12 x 8 x 2 mm

Bluetooth function of the combined module to connect all control units on the bike like shifter etc. Secure proprietary mode for service personal only, to upload specific FW updates to e.g. the motor.

HUMIDITY & TEMPERATURE

WSEN-HIDS

- 16 bit humidity and temperature output
- I²C interface
- 1.5 x 1.5 x 0.5 mm

Environmental condition tracking within the battery or the engine. Recognizing exceptional conditions like penetrating moisture.

ACCELERATION

WSEN-ITDS

- 3 axis acceleration
- 14 bit output resolution
- ±2g, ±4g, ±8g, ±16g
- 2 x 2 x 0.7 mm

Detection of shock and mechanical influence and stress. Recognizing movement of the e-bike while being supposed to be stationary.

GYRO

WSEN-ISDS

- 6 axis acceleration
- 16 bit output resolution
- ±2g, ±4g, ±8g, ±16g
- 3 x 2.5 x 0.86 mm

Measuring the orientation of the bike. Can be used as compass to enhance the navigation.

IOT DESIGN KIT

- Available as WiFi (Calypso) and Cellular (Adrastea) Design Kit
- Tool for simple Cloud Connectivity Prototyping
- Send data to any cloud for further use
- Create real IoT use cases
- Examples and Sourcecode available on GitHub for Microsoft Azure and Amazon Web Services



CHARGING INFRASTRUCTURE

CONNECTING THE KEY INFRASTRUCTURE OF TOMORROW FOR EASY USABILITY AND INCREASED USER CONSENT

As e-mobility will be more and more a key for sustainable transportation, future charging infrastructure has to be both, smart and easy to use and also future proof and connected.



Especially the connection between different charging stations with each other and also the charged devices have to be able to communicate with the infrastructure directly. Additionally there is a third party in here – the human wishing to be able to communicate with the infrastructure and expressing his plans and wishes. All that can be achieved with clever communication possibilities: Connecting the charging stations with each other could be reached with clever mesh solutions, so that there is no additional wiring needed. Communicating with the cars themselves could be done via cellular communication. The direct communication to the user could be implemented either also via cellular or with direct Bluetooth or WiFi Interface.



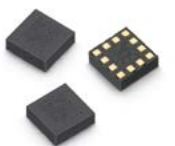
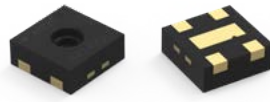

With smart MEMS sensors, a bunch of information could be generated to know as much as possible of the device.

For Payment cases there could also be the need of widespread communication standards as wM-Bus gives the possibility to communicate standardized to Smart Meter Gateway (SMGW).

Benefits

- ✓ Empowering the infrastructure
- ✓ Easy installation and extension
- ✓ Scalability
- ✓ Increasing peoples consent because of easy usage

<p>ACCELERATION</p>  <p>WSEN-ITDS</p> <ul style="list-style-type: none"> 3 axis acceleration 14 bit output resolution ±2g, ±4g, ±8g, ±16g 2 x 2 x 0.7 mm <p>3D-orientation and TAP detection as input method for the screen.</p>	<p>HUMIDITY & TEMPERATURE</p>  <p>WSEN-HIDS</p> <ul style="list-style-type: none"> 16 bit humidity and temperature output I²C interface 1.5 x 1.5 x 0.5 mm <p>Environmental condition like penetrating moisture or over temperature leading to a reduced charging power.</p>	<p>RESIDUAL CURRENT</p>  <p>WE-RCDS</p> <ul style="list-style-type: none"> DC 6 mA residual direct current detecting RDC-M-Module for mode 3 EV charging <p>Residual current detection sensor designed for wallbox application to meet IEC 62955: 2018.</p>	<p>CELLULAR & POSITIONING</p>  <p>Adrastea-I</p> <ul style="list-style-type: none"> LTE-NB.IoT / Cat.M1 incl. GNSS 14 x 13 x 2 mm <p>Far distance maintenance access – remote control and exact location of the charging station as well as exact timing information for synchronisation.</p>
---	---	--	---

<p>WIRELESS M-BUS</p>  <p>Metis-II</p> <ul style="list-style-type: none"> 868 MHz RF Pad / PCB Antenna 14 dBm output power 27 x 17 x 3.8 mm <p>Wireless connection to read out multiple meters without wiring effort.</p>	<p>WIREPAS</p>  <p>Thetis-I</p> <ul style="list-style-type: none"> Wirepas routing mesh protocol, 2.4 GHz +6 dBm output power 8 x 12 x 2 mm <p>Meshing up multiple charger stations for balancing the load effectively.</p>	<p>WIFI / BLUETOOTH</p>  <p>Stephano-I:</p> <ul style="list-style-type: none"> Bluetooth® LE 5 & WiFi 13 dBm Output power 13 x 9.5 x 2 mm <p>Connectivity as service interface and for taking into operation.</p>	<p>IOT DESIGN KIT</p>  <ul style="list-style-type: none"> Available as WiFi (Calypso) and Cellular (Adrastea) Design Kit Tool for simple Cloud Connectivity Prototyping Send data to any cloud for further use Create real IoT use cases Examples and Sourcecode available on GitHub for Microsoft Azure and Amazon Web Services
--	---	---	---

AUTOMATED GUIDED VEHICLES

SMART INDUSTRY – AUTOMATED GUIDED VEHICLES

Automatic Guided Vehicles (AGV) or Autonomous Mobile Robots (AMR) are vitally important for flexible intralogistics concepts. While GNSS can be used for navigation outdoors, robots in factories and warehouses need different orientation techniques.

Key factors for the navigation of AMRs are wireless communication and acceleration sensors for inertial navigation. Würth Electronic does not only offer sensor and radio modules but also supports various communication protocols. Orientation via anchor point antennas distributed on the factory or warehouse floor as well as transmission of orders and status updates can be realized, e.g. with Bluetooth, Wirepas Massive Routing Mesh, or WE-ProWare Flooding Mesh.

Benefits

Autonomous Mobile Robots – autonomous but well connected

- ✓ Communication with intralogistics vehicles can be realized over a variety of protocols - even proprietary solutions might prove to be a good solution.
- ✓ With wireless communication, all kinds of information can be shared, e.g. battery charge status, transport weight, or condition of wear parts.

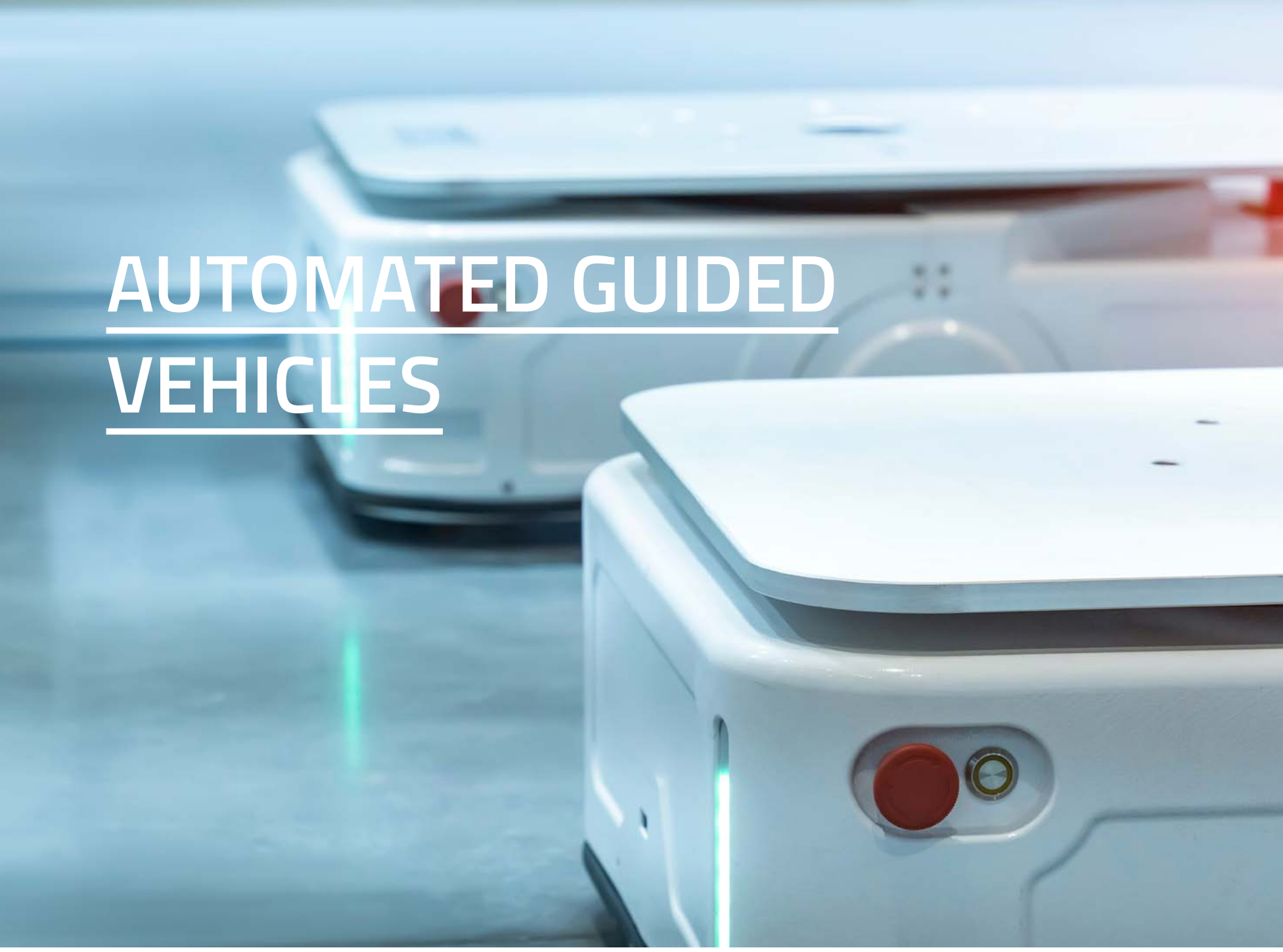

PROPRIETARY 



Tarvos-III

- 868 MHz
- RF Pad / PCB Antenna
- 14 dBm output power
- 27 x 17 x 3.8 mm

Sub-GHz radio communication in industrial environment offers reliability.

BLUETOOTH 



Proteus-III

- Bluetooth® LE 5.1
- Nordic nRF52840
- 8 dBm output power
- 12 x 8 x 2 mm

Find a specific robot selected using the function "Direction Finding" to navigate the user to the tool.

ACCELERATION 



WSEN-ITDS

- 3 axis acceleration
- 14 bit output resolution
- ±2g, ±4g, ±8g, ±16g
- 2 x 2 x 0.7 mm

Sensing movement or crash detection.

WIREPAS 



Thetis-I

- Wirepas routing mesh protocol, 2.4 GHz
- +6 dBm output power
- 8 x 12 x 2 mm

Find a specific robot selected using Wirepas Positioning Engine.



PEDESTRIANS & TRAFFIC SAFETY



SMART SAFETY BARRIERS

Road side safety barriers ensure safety of pedestrians and traffic during construction and in case of accidents. Often these cones get displaced posing a threat to human life. Retrofitting these barriers with sensors ensures early detection of displacement thereby saving human lives.

An acceleration sensor can be used to detect a fall of a safety barrier and a positioning system accurately determines the position and timing of the barrier. This data can be transmitted via cellular link to a data platform. A cloud platform can be further used to analyse and notify the operator to take corrective action when necessary.

Benefits

- ✓ Using highly integrated intelligent sensors from WE, it is possible to accurately detect falls.
- ✓ The highly accurate GNSS modules can detect slightest change in position of the barrier.
- ✓ Cellular module ensure cost effective connectivity from anywhere.
- ✓ Mesh networking between the barriers opens up a lot of possibilities for lighting control, traffic management and active signalling.

ACCELERATION



WSEN-ITDS

- 3 axis acceleration
- 14 bit output resolution
- ±2g, ±4g, ±8g, ±16g
- 2 x 2 x 0.7 mm

Sensing Acceleration for vandalism protection.

CELLULAR & POSITIONING



Adrastea-I

- LTE-NB.IoT / Cat.M1
- incl. GNSS
- 14 x 13 x 2 mm

Connect the control unit to the internet: Cloud connectivity for status informations, changes to the settings from anywhere in the world etc. and localization of each single unit in case of theft or finding all owned units.

COMBINED



Setebos-I

- Bluetooth® LE 5.1 & WE-ProWare 2.4 GHz
- 8 dBm output power
- 12 x 8 x 2 mm

Interconnecting all sensors through the WE-ProWare mesh, while offering mobile device access through Bluetooth in one device.

IOT DESIGN KIT



- Available as WiFi (Calypso) and Cellular (Adrastea) Design Kit
- Tool for simple Cloud Connectivity Prototyping
- Send data to any cloud for further use
- Create real IoT use cases
- Examples and Sourcecode available on GitHub for Microsoft Azure and Amazon Web Services

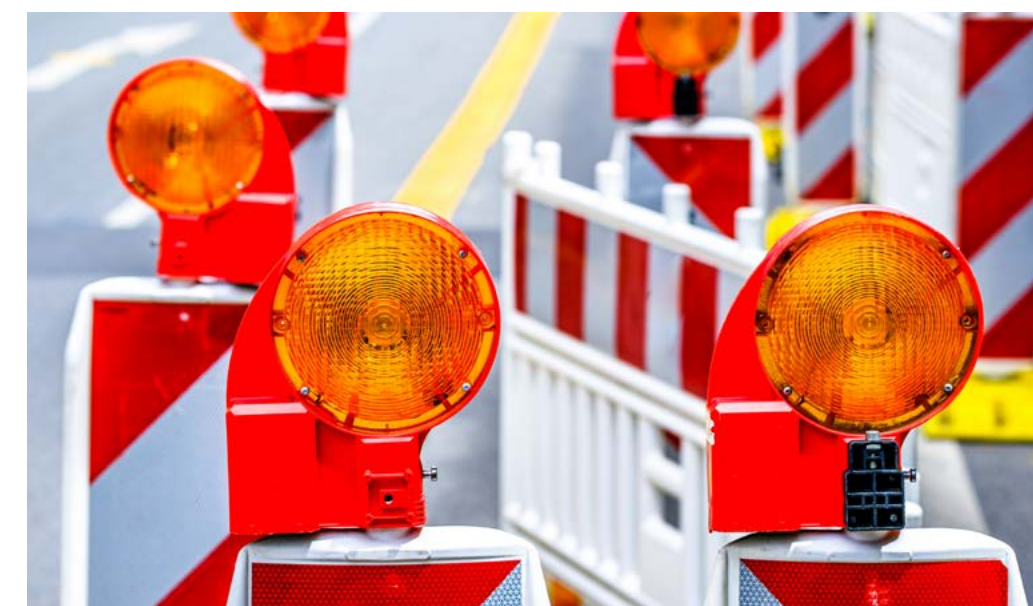



SMART FARMING

TAKE YOUR FARMING TO THE NEXT LEVEL

Climate change, loss of arable land, ever scarcer resources and a growing world population. There are more and more challenges in food production. New approaches are being sought to meet these challenges. One of them is smart farming.

With our WE line of FeatherWings you can rapidly prototype your own smart farming application. With the help of the Sensor FeatherWing you can measure data points such as temperature and humidity to check if the plants are feeling most comfortable.

This created data can be sent into any cloud using the Calypso WiFi FeatherWing. On Github, we are providing quickstarts and example-code to get data into Microsoft and Amazon IoT platforms. Here, the data can be displayed, stored and analyzed to optimize plant output.

Benefits

Actuators can now be controlled manually or automatically via RPC

- ✓ Turn on water pump to water the soil if the moisture is too low.
- ✓ Automatically fertilize the soil.
- ✓ Change the color and brightness of the LED depending on the time of day and the development of the plant.

CREATE DATA



Sensor FeatherWing

4 sensors connected over shared I²C in Adafruit Feather form-factor

- WSEN-TIDS for temperature sensing
- WSEN-HIDS for humidity sensing

Sensing environmental conditions like temperature and potting soil humidity

SEND DATA



Calypso WiFi FeatherWing

- WiFi-Connection 2.4 GHz
- Easy connection to Smart Devices
- Sending data to the server
- Handling multiple sensor nodes

Sending the collected data from the sensors into the cloud platform

IOT DESIGN KIT



- Available as WiFi (Calypso) and Cellular (Adrastea) Design Kit
- Tool for simple Cloud Connectivity Prototyping
- Send data to any cloud for further use
- Create real IoT use cases
- Examples and Sourcecode available on GitHub for Microsoft Azure and Amazon Web Services

ILLUMINATION



WL-SMDC

- Mono and full colour LEDs available
- Suitable for vertical farming & lighting in greenhouses
- High PPF and PPE
- Available in mid and high power packages

WE can create target light recipes that promote specific quality parameters of the plant, such as improved root development, increased biomass etc.

POWER



WPME-LDHM

- $V_{IN} = 4.5 - 60 V$
- Up to 16 high power 3.2 V LEDs
- $I_{OUT} = 0.3 \text{ to } 0.45 A$
- $9.85 \times 10.16 \times 4.57 \text{ mm}$

Mag³C power module - a fully integrated constant-current LED driver. LED driver with PWM and analog dimming.



INTELLIGENT IRRIGATION



CONNECTIVITY – INTELLIGENT IRRIGATION

A green garden is the jewel of any private or public building. But irrigation should be managed wisely. Especially in times of water scarcity, only as much water as necessary should be fed into the sprinkler system. With connectivity and sensors, sprinkler systems become intelligent.

A smart water pump detects when it is the right time to water the garden – based on wirelessly connected soil moisture sensors, the time of day, and maybe even from data about the availability of water resources like a cistern. By using several intelligent water pumps, gardens or parks can also be partially irrigated. Developers of irrigation systems should consider using humidity sensors and connectivity solutions like WE-ProWare Flooding Mesh or Wirepas Massive Routing Mesh to offer smart solutions which help their customers to save water.

Benefits

Mesh networks to control sprinklers

- ✓ An internet connection and cloud service can further enhance the benefits of a smart irrigation system.
- ✓ The user can analyze statistics on water consumption and watering times via a smartphone.

Industry

Mobility

Automation & Smart Home

Consumer

Energy

Medical

WIFI 



Calypso

- IEEE 802.11 b/g/n, 2.4 GHz
- +18 dBm output power
- 19 x 27.5 x 4 mm

Connect the central water pump to the Internet.

HUMIDITY & TEMPERATURE 

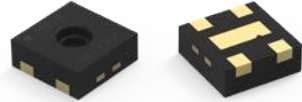

WSEN-HIDS

- 16 bit humidity and temperature output
- I²C interface
- 1.5 x 1.5 x 0.5 mm

Sensing outdoor humidity and temperature directly at the required planting bed.

ACCELERATION 



WSEN-ITDS

- 3 axis acceleration
- 14 bit output resolution
- ±2g, ±4g, ±8g, ±16g
- 2 x 2 x 0.7 mm

Sensing Acceleration for vandalism protection. Theft protection in case of movement.

MESH 



Thetis-I

- Wirepas routing mesh protocol, 2.4 GHz
- +6 dBm output power
- 8 x 12 x 2 mm

Connecting hundreds of intelligent water sprinkler through a battery-saving routing mesh

LONG-RANGE-WAN



Daphnis-I

- 868 MHz
- Supported long-range-WAN Classes A, B and C
- 15 x 16 x 3 mm

Connecting devices over big distance and sending data to a gateway.



SMART BUILDING – VANDALISM PROTECTION

Electronic devices such as motion detectors or video cameras for surveillance purposes which are installed in public or easily accessible areas are particularly at risk. Criminals will always try to destroy these devices first. Therefore, the intentional destruction of such electronic devices must be detected and reported immediately.

To be able to detect any tampering with a surveillance device, a sensitive 3D acceleration sensor and a radio module should be integrated. With the high-quality and power-saving components from Würth Elektronik, solutions can be developed that immediately sound the alarm, if someone tampers with a surveillance camera or motion detector.

Benefits

Protect the protecting devices

- ✓ An alarm quickly puts burglars into flight, and you are alerted yourself. With an internet connection, a direct emergency call can also be sent.
- ✓ In addition to the main function of motion detection or image recording, cost-effective secondary functions for surveillance are available, e.g. measurement of temperature, humidity and atmospheric pressure.

VANDALISM PROTECTION



WIFI



Calypso

- IEEE 802.11 b/g/n, 2.4 GHz
- +18 dBm output power
- 19 x 27.5 x 4 mm

Connect the camera to the internet for remote control functions.

HUMIDITY & TEMPERATURE



WSEN-HIDS

- 16 bit humidity and temperature output
- I²C interface
- 1.5 x 1.5 x 0.5 mm

Sensing Room or Outdoor temperature & Humidity.

ACCELERATION

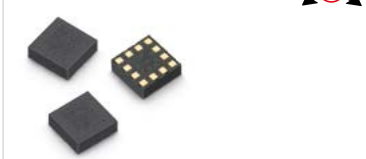

WSEN-ITDS

- 3 axis acceleration
- 14 bit output resolution
- ±2g, ±4g, ±8g, ±16g
- 2 x 2 x 0.7 mm

Sensing Acceleration for vandalism protection. Tamper detection is the ability of a device to sense an active attack to the device and the threat of the attack should initiate an event (e.g. alarm, shutdown of the device).

POWER

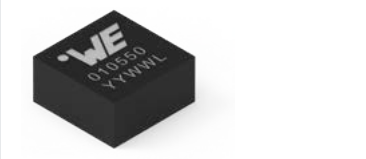

WPME-VDMM

- V_{IN} = 2.5 - 5.5 V
- V_{OUT} = 0.85 - 5.5 V
- I_{OUT} = 1.2 A
- 2.5 x 2.5 x 1.2 mm

MagI³C power module - a fully integrated DC-DC converter. High power density for a Cool design. Adjustable output.

ILLUMINATION



WI-SIQW

- High power output IR LED
- QuadFrame NoLead package
- Peak wavelengths: 850 nm & 940 nm
- 2720,3535,3737 sizes available

IR LEDs are used to illuminate areas with infrared light, which is invisible to the human eye but can be detected by special cameras.



PESTICIDE MONITORING

CONTROLLED PESTICIDE SPRAY SYSTEM

In this country local laws govern and limit usage of pesticide. In order to comply with environmental laws, a black box on the tractor monitors the amount of pesticide dispensed on the land allocated to the farmer. This way the amount of sprayed pesticide is controlled and overdosing is avoided.

In the pump box of the spraying installation mounted on the tractor, a radio module receives data from the spray nozzles. Every nozzle is fitted with differential pressure sensors monitoring an equal flow, and their radio module transmits in the correct time slot the flow figure. In the central unit the metrics are computed in order to match the volume of pesticide to the surface on which the tractor has covered.

To refine the calculation, GNSS can be added to match the volume to the land surface, and NB-IoT / LTE-M can be implemented in case the governing authority requests that the data should be stored on a server.

Benefits

Quick win of using a radio module or a sensor

- ✓ Closed & reliable control loop of the dispensing system
- ✓ Local and global access to any connected system in order to monitor & control pesticide usage
- ✓ Each spray nozzle for the pesticide can be controlled individually
- ✓ Saving the lives of many small creatures



DIFFERENTIAL PRESSURE

WSEN-PDUS

- 15 bit digital output
- Analog & I²C interface
- 13.3 x 8 x 7.55 mm

Measuring & Monitoring an equal dispensing across different nozzles.

CELLULAR & POSITIONING

Adrastea-I

- LTE-NB.IoT / Cat.M1
- incl. GNSS
- 14 x 13 x 2 mm

Enabling direct cloud access through cellular technology makes predictive maintenance real.

PROPRIETARY

Tarvos-III

- 868 MHz
- RF Pad / PCB Antenna
- 14 dBm output power
- 27 x 17 x 3.8 mm

Telesto-III

- 915 MHz
- RF Pad / PCB Antenna
- 14 dBm output power
- 27 x 17 x 3.8 mm

Collecting and sending data from sensor nodes in the pesticide spray system and transmitting those values to the cellular gateway For US customers, the 868 MHz radio module can be replaced by its 915 MHz pin- and software compatible counterpart, Telesto-II.

ACCELERATION

WSEN-ITDS

- 3 axis acceleration
- 14 bit output resolution
- ±2g, ±4g, ±8g, ±16g
- 2 x 2 x 0.7 mm

Predictive Maintenance means checking the system if there are any notices of spraying arms unbalance.



KEYLESS ENTRY



KEYLESS ENTRY VIA BLUETOOTH AND AN APPROPRIATE APP

Who does not know it - forgot the key and locked out. Furthermore, they are uncomfortable in the pants or get lost in the handbag.

With the help of a unique assignment via Bluetooth and the appropriate app, such door opening systems are both secure and comfortable using a mobile device.

Benefits

- ✓ Fingerprints can also be stored or a numerical code can be used.
- ✓ The systems can also be protected by an acceleration sensor to trigger an alarm in the event of damage, for example.

BLUETOOTH



Proteus-I/-II

- Bluetooth® LE 4.2
- Bluetooth® LE 5.0
- Nordic nRF52832
- 3 dBm output power
- 11 x 8 x 2 mm

Connect to Mobile Device and connect Keys to Keypad.

ACCELERATION



WSEN-ITDS

- 3 axis acceleration
- 14 bit output resolution
- ±2g, ±4g, ±8g, ±16g
- 2 x 2 x 0.7 mm

Sensing Acceleration for vandalism protection, e.g. tamper detection

SIGNAL INDICATOR



WL-ICLED

- Compatible with open source libraries
- 0% to 100% digital dimming via PWM
- Individual pixel colour and brightness control
- 2020, 2121, 3210 sideview and 5050 sizes available

ICLEDs allow for precise colour and brightness customization. They enable dynamic lighting effects and colour sequences with just a single data line.

POWER

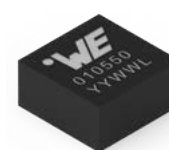

WPME-VDMM

- $V_{IN} = 2.5 - 5.5 V$
- $V_{OUT} = 0.85 - 5.5 V$
- $I_{OUT} = 1.2 A$
- 2.5 x 2.5 x 1.2 mm

MagI³C power module - a fully integrated DC-DC converter. High power density for a Cool design. Adjustable output.

CONNECTION



WR-MJ

- Ethernet Category 3 to 6A

Connect the Smart Power Distribution and Relay Controller to the home internet gateway.





CONNECTED LIGHTING

SMART BUILDING – CONNECTED LIGHTING & ROOM CONDITIONING

Building automation is a great way to make indoor living more comfortable while saving energy. Lighting, heating, and ventilation systems only become really smart when they are adequately interconnected.

Sensors for humidity, temperature or CO² are needed to measure indoor air quality, as are connections to heating and ventilation systems, automatic window opening and shading systems. WiFi is suitable for connecting the gateway to the Internet for remote control, while mesh networks such as WE-ProWare are state of the art for interconnecting all sensors and actuators, light switches, and air conditioners.

Benefits

Mesh networks to control the ambience

- ✓ Smart lighting and air-conditioning serve our well-being.
- ✓ Connected lighting and room conditioning can be used to save energy.
- ✓ With a connection to the Internet, the system can additionally be managed by a mobile app.

COMBINED  



Setebos-I

- Bluetooth® LE 5.1 & WE-ProWare 2.4 GHz
- 8 dBm output power
- 12 x 8 x 2 mm

Interconnecting all sensors through the WE-ProWare mesh, while offering mobile device access through Bluetooth in one device.

WiFi 



Calypso

- IEEE 802.11 b/g/n, 2.4 GHz
- +18 dBm output power
- 19 x 27.5 x 4 mm

Gateway connection from Mesh to the Internet.

HUMIDITY & TEMPERATURE 



WSEN-HIDS

- 16 bit humidity and temperature output
- I²C interface
- 1.5 x 1.5 x 0.5 mm

Measuring local room temperature & humidity simultaneously.

TEMPERATURE 



WSEN-TIDS

- Silicon based digital temperature sensor
- High accuracy (up to ±0.25 °C typ.)
- Fully calibrated 16 bit temperature output

Measuring room temperature.

ACCELERATION 



WSEN-ITDS

- 3 axis acceleration
- 14 bit output resolution
- ±2g, ±4g, ±8g, ±16g
- 2 x 2 x 0.7 mm

Recognizing movement of particular inventory like expensive art.

ABSOLUTE PRESSURE 

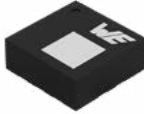

WSEN-PADS

- 26 – 126 kPa
- 260 – 1260 mbar
- 24 bit output resolution
- 2 x 2 x 0.8 mm

Measuring local room air pressure to monitor unforeseen window openings e.g. during a burglary.

WIRELESS ALARM SYSTEM



SMART HOME – WIRELESS ALARM SYSTEM









Older houses often have many weak points and are particularly vulnerable to burglary. However, retrofitting wired security devices is expensive and laborious. Manufacturers should therefore also offer radio-based alarm systems.

The development of retrofitable alarm systems with wireless technology depends on the right combination of radio technologies. For the control system, a connection to the Internet or to the mobile network is required. For connecting the sensors, radio frequencies in the sub-GHz and the 2.4 GHz range can be used, whereas both short and longer distances have to be bridged. Due to security reasons, the use of a long-established but not publicly known radio protocol, such as WE-ProWare by Würth Elektronik, is very advantageous. Intelligent sensor technology can detect the opening of windows or doors by measuring the change in barometric pressure, temperature or humidity and trigger a silent alarm.

Benefits

Proprietary radio protocol – a security advantage

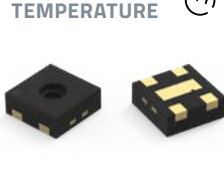
- ✓ By intelligent combination and utilization of highly sensitive Würth Elektronik sensors, the opening of windows and doors can be detected without equipping the doors themselves with sensors.
- ✓ A wide range of Würth Elektronik radio modules allows variants for different spatial conditions.
- ✓ Arming and disarming of the alarm system can be executed via mobile devices if an internet connection via WiFi or cellular module is established.

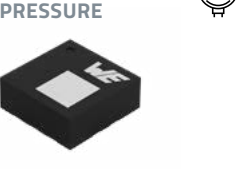
<p>PROPRIETARY</p>  <p>Tarnos-III</p> <ul style="list-style-type: none"> 868 MHz RF Pad / PCB Antenna 14 dBm output power 27 x 17 x 3.8 mm <p>The flooding mesh network of the WE-ProWare offers hundreds of alarm sensors to be connected secure and reliable.</p>	<p>WE-PRO WARE</p>  <p>Thyone-I</p> <ul style="list-style-type: none"> 2.4 GHz Smart antenna selection 8 dBm output power 12 x 8 x 2 mm 	<p>WIFI</p>  <p>Calypso</p> <ul style="list-style-type: none"> IEEE 802.11 b/g/n, 2.4 GHz +18 dBm output power 19 x 27.5 x 4 mm <p>Connecting the alarm system main console to the local WiFi.</p>	<p>BLUETOOTH</p>  <p>Proteus-III</p> <ul style="list-style-type: none"> Bluetooth® LE 5.1 Nordic nRF52840 8 dBm output power 12 x 8 x 2 mm <p>Accessing the alarm system settings from a mobile device in a short range.</p>	<p>CELLULAR</p>  <p>Adrastea-I</p> <ul style="list-style-type: none"> LTE-NB.IoT / Cat.M1 incl. GNSS 14 x 13 x 2 mm <p>Connecting the alarm system main console to the cellular network.</p>	<p>COMBINED</p>  <p>Setebos-I</p> <ul style="list-style-type: none"> Bluetooth® LE 5.1 & WE-ProWare 2.4 GHz 8 dBm output power 12 x 8 x 2 mm <p>Interconnecting all sensors through the WE-ProWare mesh, while offering mobile device access through Bluetooth in one device.</p>	<p>HUMIDITY & TEMPERATURE</p>  <p>WSEN-HIDS</p> <ul style="list-style-type: none"> 16 bit humidity and temperature output I²C interface 1.5 x 1.5 x 0.5 mm <p>Measuring local room temperature & humidity simultaneously.</p>	<p>ACCELERATION</p>  <p>WSEN-ITDS</p> <ul style="list-style-type: none"> 3 axis acceleration 14 bit output resolution ±2g, ±4g, ±8g, ±16g 2 x 2 x 0.7 mm <p>Recognizing movement of particular inventory like expensive art.</p>	<p>ABSOLUTE PRESSURE</p>  <p>WSEN-PADS</p> <ul style="list-style-type: none"> 26 – 126 kPa 260 – 1260 mbar 24 bit output resolution 2 x 2 x 0.8 mm <p>Measuring local room air pressure to monitor unforeseen window openings e.g. during a burglary.</p>
--	--	--	---	--	---	--	---	--

IOT-WASHING MACHINE



SMART HOME – IOT-WASHING MACHINE

Smart homes need smart washing machines. Only a washing machine which is connected to the Internet of Things can be controlled remotely and switched on, for example, when there is a surplus of energy from the house's solar panels. Really smart machines come with excellent sensors.

Manufacturers who make their washing machines "intelligent" are opening up completely new business models. Machines that receive commands and provide feedback wirelessly can be sold as components of smart home concepts. If absolute pressure, differential pressure, temperature, and acceleration sensors are used to monitor the correct operation of a washing machine, leasing models can be developed, in which the customer only pays for actual use, for example in a laundromat or communal laundry. At the same time, the machine automatically reports the need for maintenance, for example, when its vibration behavior changes the material.

Benefits

Laundry becomes more sustainable

- ✓ Do not own, just use. Smart IoT machines are perfectly maintained machines – leasing becomes an attractive option for customers as well as for manufacturers.
- ✓ Robust and durable sensors from Würth Elektronik for long-lasting smart machines.
- ✓ Intelligent sensors, such as the differential pressure sensor, detect blocked filters.
- ✓ Personalized washing programs via mobile app and Bluetooth control.

ABSOLUTE PRESSURE

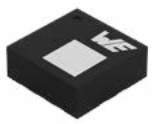

WSEN-PADS

- 26 – 126 kPa
- 260 – 1260 mbar
- 24 bit output resolution
- 2 x 2 x 0.8 mm

Measuring the water level through pressure in the washing machine.

HUMIDITY & TEMPERATURE



WSEN-HIDS

- 16 bit humidity and temperature output
- I²C interface
- 1.5 x 1.5 x 0.5 mm

Measuring humidity & temperature in the drum while drying process.

DIFFERENTIAL PRESSURE



WSEN-PDUS

- 15 bit digital output
- Analog & I²C interface
- 13.3 x 8 x 7.55 mm

Measuring the pre- and post-pressure of a filter to detect filter contamination.

TEMPERATURE



WSEN-TIDS

- Silicon based digital temperature sensor
- High accuracy (up to ±0.25 °C typ.)
- Fully calibrated 16 bit temperature output

Measuring the temperature in the drum while drying process.

ACCELERATION



WSEN-ITDS

- 3 axis acceleration
- 14 bit output resolution
- ±2g, ±4g, ±8g, ±16g
- 2 x 2 x 0.7 mm

Monitoring and analyzing a possible unbalance of the washing drum.

BLUETOOTH



Proteus-III

- Bluetooth® LE 5.1
- Nordic nRF52840
- 8 dBm output power
- 12 x 8 x 2 mm

Bluetooth connectivity for mobile control or as technician interface.

WIFI



Calypso

- IEEE 802.11 b/g/n, 2.4 GHz
- +18 dBm output power
- 19 x 27.5 x 4 mm

Connecting the washing machine to the Internet.

COMBINED



Stephano-I

- IEEE 802.11 b/g/n, 2.4 GHz
- Bluetooth® LE 5.0
- 13 x 9.5 x 2 mm

Connecting to the internet via WiFi and to end users smart devices via Bluetooth®.



INTELLIGENT COFFEE MACHINE

SMART HOME – INTELLIGENT COFFEE MACHINE

Coffee machines are popular and in daily use. Modern machines allow creative compositions of personalized coffee variants. At the same time, leasing models are increasingly based on so-called wet hours or actual consumption – smart solutions are required.

Humidity and temperature sensors as well as Bluetooth, WiFi and cellular modules from Würth Elektronik: Equipped in this way, a coffee machine can become a smart device. With the help of integrated humidity and temperature sensors, it is possible to control the machine's optimal functioning. A change of the machine's values indicates a malfunction, which means that the need for maintenance can be displayed at an early stage or reported directly to a service center. In leasing, a billing system can be realized through live data transfer to the cloud. Convenient for the user: By using a mobile app, each user can design his or her personal coffee and preset, e.g. the amount of coffee, milk, or water.

Benefits

Coffee pleasure with pay per use

- ✓ With the connection to the Internet, a technician can get access to usage and consumption data at any time. The supplier of coffee, cocoa powder or milk will be on site only if necessary. This saves resources and protects the environment.
- ✓ Personalized coffee preferences can be adjusted via smartphone.
- ✓ Instead of paying a fixed monthly fee, the customer only pays for actual consumption.

HUMIDITY & TEMPERATURE

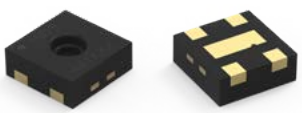

WSEN-HIDS

- 16 bit humidity and temperature output
- I²C interface
- 1.5 x 1.5 x 0.5 mm

Measuring Humidity and Temperature ensures an optimal function and taste.

BLUETOOTH



Proteus-III

- Bluetooth® LE 5.1
- Nordic nRF52840
- 8 dBm output power
- 12 x 8 x 2 mm

Connect to mobile App to preset your personal coffee or also as service interface for the technician.

WIFI



Calypso

- IEEE 802.11 b/g/n, 2.4 GHz
- +18 dBm output power
- 19 x 27.5 x 4 mm

Live data transfer to the cloud platform within a WiFi network.

COMBINED



Stephano-I

- IEEE 802.11 b/g/n, 2.4 GHz
- Bluetooth® LE 5.0
- 13 x 9.5 x 2 mm

Connecting to the internet via WiFi and to end users smart devices via Bluetooth®.

CELLULAR



Adrastea-I

- LTE-NB.IoT / Cat.M1
- incl. GNSS
- 14 x 13 x 2 mm

Live data transfer to the cloud platform from anywhere.





SMART SPORT EQUIPMENT

MODERN FITNESS GADGETS HAVE TO BE SMART, CONNECTABLE AND UPDATEABLE – TO VISUALIZE YOUR TRAINING PROGRESS

With the newest sport equipment you can track your training status, choose your favorite mode and connect yourself with other users. Connecting punching balls, dumbbells, balls and lot more allows a smart way to connect the personal training to friends and colleagues and brings a high motivation in competing each other.

Würth Elektronik offers Bluetooth and WiFi to connect the smartphone to your favorite sport device. Quantities of pushes, measuring strength of a hit or counting time of a movement is all digital information, you did not have in the past in personal training. With this data it is possible to empower the athlete in documenting and recognising changes and developments as well as there is the possibility of competing.

MEMS acceleration sensors are a very easy and cost effective way to raise this information. With Bluetooth Low Energy this data can be sent easily to the users smart device and directly into a competition cloud. Highest security requirements can be fulfilled.

Benefits

- ✓ Transparent training status
- ✓ Easy installation and extension
- ✓ Adaptable equipment
- ✓ Share your training progress online
- ✓ Online events

GYRO 



WSEN-ISDS

- 6 axis acceleration
- 16 bit output resolution
- ±2g, ±4g, ±8g, ±16g
- 3 x 2.5 x 0.86 mm

Detection of spin in balls.

ACCELERATION 

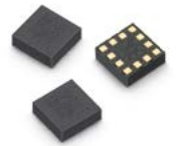

WSEN-ITDS

- 3 axis acceleration
- 14 bit output resolution
- ±2g, ±4g, ±8g, ±16g
- 2 x 2 x 0.7 mm

Detection of shock and force like punching power.

ABSOLUTE PRESSURE 



WSEN-PADS

- 26 – 126 kPa
- 260 – 1260 mbar
- 24 bit output resolution
- 2 x 2 x 0.8 mm

Detection of height changes.

BLUETOOTH 



Proteus-e

- Bluetooth® LE 5.1
- Nordic nRF 52805
- 4dBm Output power
- 9 x 7 x 2 mm

Transfer data to the smartphone like:

- tracking the performance
- real-time statistics
- choose training modes

IOT DESIGN KIT 



- Available as WiFi (Calypso) and Cellular (Adrastea) Design Kit
- Tool for simple Cloud Connectivity Prototyping
- Send data to any cloud for further use
- Create real IoT use cases
- Examples and Sourcecode available on GitHub for Microsoft Azure and Amazon Web Services



INTELLIGENT HOUSEKEEPING



NOT ONLY THE MOST ACCIDENTS HAPPEN IN THE HOUSEHOLD – IT IS ONE OF THE AREAS WHERE SMART TECHNOLOGY CAUSES THE BIGGEST COMFORT INCREASE

With raising tehcnologie possibilities also the housekeeping gets more and more automated, intelligent and more comfortable. To do so, a lot of sensors and connectivity functions are needed. All data has to be sent via WiFi through the internet to userfriendly server applications.

In smart cleaning devices a lot of physical values are of interest. Temperatures have to be monitored, pressures, esp. for vacuums, have to be checked. You have to be sure, no humidity attacking your device. And lot more.

With Würth Elektronik digital MEMS Sensors there is a bunch of possibilities to collect data. Data of course is only useful if you know how to use it. Therefore a communication to the device itself but also to the controlling user or cloud systems above is important. With Bluetooth a communication directly to a smart device is easy and a taking into operation is possible without problems. WiFi enables to sent the data into a cloud and then to send back again to the user. And also brand new technologies like Matter can be integrated with radio modules.

Benefits

- ✓ Easy collecting data
- ✓ Standard connection to users
- ✓ Increase comfort level

GYRO

WSEN-ISDS

- 6 axis acceleration
- 16 bit output resolution
- ±2g, ±4g, ±8g, ±16g
- 3 x 2.5 x 0.86 mm

The gyroscope enables indoor navigation and movement detection.

ACCELERATION

WSEN-ITDS

- 3 axis acceleration
- 14 bit output resolution
- ±2g, ±4g, ±8g, ±16g
- 2 x 2 x 0.7 mm

Easy detection of static or moving devices for energy saving and reactivation.

ABSOLUTE PRESSURE

WSEN-PADS

- 26 – 126 kPa
- 260 – 1260 mbar
- 24 bit output resolution
- 2 x 2 x 0.8 mm

Detection of height changes.

BLUETOOTH

Proteus-e

- Bluetooth® LE 5.1
- Nordic nRF 52805
- 4dBm Output power
- 9 x 7 x 2 mm

Transfer data to the smartphone like:

- tracking the performance
- real-time statistics

DIFFERENTIAL PRESSURE

WSEN-PDUS

- ± 100mbar
- ± 10 kPa
- 15 bit resolution
- 13 x 8 mm

Sensing the pneumatic pressure inside vacuum cleaner applications.

WIFI

Calypso

- IEEE 802.11 b/g/n, 2.4 GHz
- +18 dBm output power
- 19 x 27.5 x 4 mm

Automatic alarm in case of low battery through WiFi network.

IOT DESIGN KIT

Available as WiFi (Calypso) and Cellular (Adrastea) Design Kit

- Tool for simple Cloud Connectivity Prototyping
- Send data to any cloud for further use
- Create real IoT use cases
- Examples and Sourcecode available on GitHub for Microsoft Azure and Amazon Web Services

SMART HELMET



WEARABLES – SMART HELMET

In the case of motorcycle accidents, it is of crucial importance to receive medical aid as soon as possible, as the collision might severely hurt internal organs. A smart helmet that can detect a crash and send an emergency alarm automatically could thus be a lifesaver.

Acceleration sensors and LTE mobile radio modules including localization (GNSS) by Würth Elektronik can be used to implement safety applications. In case the sensor system detects the movement pattern of a collision, an emergency call will automatically be sent or predefined persons could be contacted.

Benefits

A helmet which is able to communicate and to collect data can increase safety and comfort of the biker.

- ✓ The condition in the helmet can be measured via additional integrated sensors, for example temperature and humidity. The driver is alerted in time and thus protected from overheating.
- ✓ In addition, a communication interface for radio contact between driver and passenger can be implemented.

HUMIDITY & TEMPERATURE

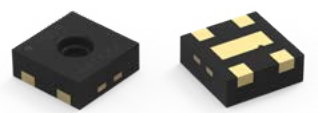

WSEN-HIDS

- 16 bit humidity and temperature output
- I²C interface
- 1.5 x 1.5 x 0.5 mm

Measuring environmental conditions in the helmet to avoid overheat in summer time or wetness in the helmet due to leakage while significant rain.

ACCELERATION



WSEN-ITDS

- 3 axis acceleration
- 14 bit output resolution
- ±2g, ±4g, ±8g, ±16g
- 2 x 2 x 0.7 mm

- Impact detection and initiating the radio module to setup an emergency call.
- Impact detection to gather information for the doctors for the grade of injury.
- Concussion detection

BLUETOOTH



Proteus-III

- Bluetooth® LE 5.1
- Nordic nRF52840
- 8 dBm output power
- 12 x 8 x 2 mm

Connection from helmet to mobile to download. Data from helmet like head movement, specific vibrations, etc.

CELLULAR & POSITIONING



Adrastea-I

- LTE-NB.IoT / Cat.M1
- incl. GNSS
- 14 x 13 x 2 mm

Communication of data inclusive localization (GNSS) to predefined receiver.





BATTERY MONITORING

CONDITION MONITORING, OBSERVING BATTERY AGEING, THEFT PROTECTION AND POWER SAVING

Batteries are driving our world. Especially in the consumer field. Remotes, toys and lots of other devices only work with energy out of batteries. Technologie enables a lot possibilities in monitoring devices and also their batteries to be able to charge or exchange them in time. Ageing batteries behave differently and carry the risk of leakage or function loss.

Sensing temperature and in some cases also humidity is the first step to get information about the used battery above the only voltage level. If you also check movement of a device with the acceleration sensors and with this offer the possibility to easily detect whether the device is moving or not. With this information, the intelligent battery can shut down devices not in use and both save energy. The integrated functionality of the sensor can wake up a microcontroller behind only as the device is moving.

Beyond that, not only the device itself can be interested in the information, also the user could use the information about the battery condition and therefore connect via Bluetooth or WiFi to the device or directly to the battery to detect the needs of the application.

Benefits

- ✓ Reducing power consumption of every portable device
- ✓ Easy to implement
- ✓ High comfort level for high quality devices possible

TEMPERATURE 



WSEN-TIDS

- Silicon based digital temperature sensor
- High accuracy (up to ± 0.25 °C typ.)
- Fully calibrated 16 bit temperature output

Precise measuring the temperature in battery cells to avoid overheating and ensuring devices operating inside the specified conditions.

HUMIDITY & TEMPERATURE 

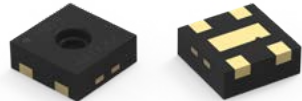

WSEN-HIDS

- 16 bit humidity and temperature output
- I²C interface
- 1.5 x 1.5 x 0.5 mm

Environmental condition tracking within the device. Recognizing exceptional conditions like penetrating moisture.

ACCELERATION 



WSEN-ITDS

- 3 axis acceleration
- 14 bit output resolution
- $\pm 2g$, $\pm 4g$, $\pm 8g$, $\pm 16g$
- 2 x 2 x 0.7 mm

Detection of movement and possible damage because of crash with free-fall detection.

BLUETOOTH 





Proteus-e

- Bluetooth® LE 5.1
- Nordic nRF 52805
- 4dBm Output power
- 9 x 7 x 2 mm

Transfer data to the smartphone like:

- batterie status
- Apple Find My functionality

WIFI 



Calypto

- IEEE 802.11 b/g/n, 2.4 GHz
- +18 dBm output power
- 19 x 27.5 x 4 mm

Automatic alarm in case of low battery through WiFi network.

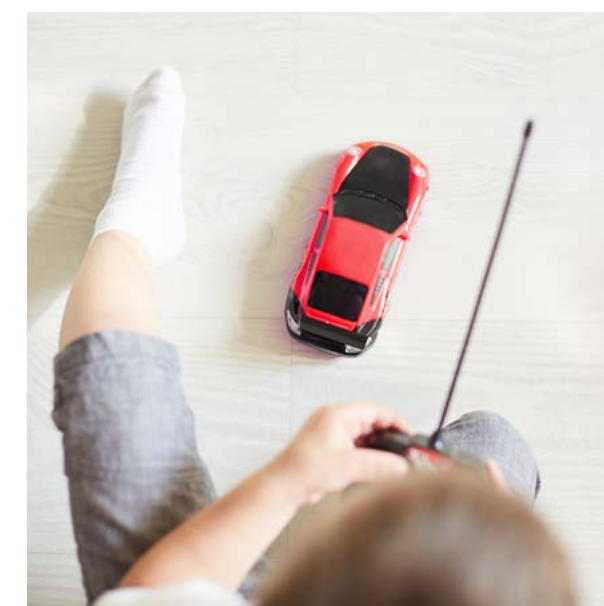

SMART METERING

SMART METERING – THE KEY TO SUCCESS IN RENEWABLE ENERGIES

With more and more renewable energies in the public power grid also the need of information about the produced energy, as well as the needed power, has to be increased significantly. Only with data the energy transformation could be managed.

With energy meters it is possible to detect energy consumptions as it is done for years. But as there are more and more decentralized energy providers producing green energy, more information is needed to transport the energy and also to use the grid securely. The measured power flows, that's where it all begins. This information has to be collected efficiently, as the energy meters should not have a high energy consumption for themselves. The very different use cases also need very different solutions.

In areas, where a lot of energy meters are installed, you should collect data from all of them and bring it into a superordinate system at one point. Predictive and curative maintenance can be triggered by intelligent digital sensors giving you the status of the environmental conditions in- and outside the housing and provides protection against natural destruction and exceptional failures.

Data can be made accessible through secure cloud connectivity.

Benefits

- ✓ Easy connecting of dozens of meters without wiring effort
- ✓ Easy installation and extension
- ✓ Scalability

WIRELESS M-BUS



Metis-II

- 868 MHz
- RF Pad Antenna
- 14 dBm output power
- 27 x 17 x 3.8 mm

Wireless connection to read out multiple meters without wiring effort.

HUMIDITY & TEMPERATURE



WSEN-HIDS

- 16 bit humidity and temperature output
- I²C interface
- 1.5 x 1.5 x 0.5 mm

Environmental condition tracking within the meters. Recognizing exceptional conditions like penetrating moisture.

CELLULAR



Adrastea-I

- LTE-NB.IoT / Cat.M1
- incl. GNSS
- 14 x 13 x 2 mm

Far distance maintenance access – remote control.

ACCELERATION

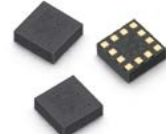

WSEN-ITDS

- 3 axis acceleration
- 14 bit output resolution
- ±2g, ±4g, ±8g, ±16g
- 2 x 2 x 0.7 mm

Detection of vandalism or mechanical stress influencing the meter.

BLUETOOTH



Proteus-e

- Bluetooth® LE 5.1
- Nordic nRF 52805
- 4dBm Output power
- 9 x 7 x 2 mm

Connect from smartphone to the meter for taking into operation and as service interface.

IOT DESIGN KIT



- Available as WiFi (Calypso) and Cellular (Adrastea) Design Kit
- Tool for simple Cloud Connectivity Prototyping
- Send data to any cloud for further use
- Create real IoT use cases
- Examples and Sourcecode available on GitHub for Microsoft Azure and Amazon Web Services



ADAPTIVE SOLAR ENERGY



OPTIMIZING ENERGY OUTPUT WITH ADAPTIVE SOLAR PANELS

The effectiveness of a solar panel is largely determined by the angle of incidence of the sun. If this angle can be dynamically adjusted, significantly higher energy yields are possible. Smart balcony power plants with batteries and wireless connectivity gives the customer insight and power to control his power usage and optimize it in order to make the most of his produced energy.

Adapting the angle of solar panels dynamically to the sun can enlarge the profit out of the panel tremendously. Using MEMS Inertial Measuring Units (IMUs) gives the possibility of sensing the orientation of the panel in relation to the earth gravity and therefore allows to bring the panel in the perfect angle to the sun at every moment during the day. With this, the outcome can be increased easily.

By connecting multiple panels or groups of panels, the adjustment can be done simultaneously or intentionally not the same way. Using Bluetooth LE brings the opportunity to get a quick and easy access to the typical waterproof manufactured housings without effort for service or taking into operation.

LTE Cat.M connectivity allows alarming in case of malfunctions or damages caused by weather or animals (as i.e. sheeps are often used as lawn trimmers in these areas. Humidity sensor based on MEMS technology allows easy calculation of dew point and whether there has to be activated any heaters in some kind of application.

Benefits

- ✓ Enlarge the outcome of the panels
- ✓ Easy connectivity to multiple panels
- ✓ Fast commissioning direct in the field

GYRO

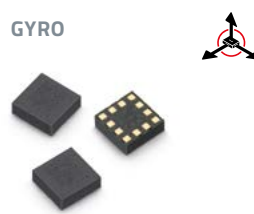

WSEN-ISDS

- 6 axis acceleration
- 16 bit output resolution
- ±2g, ±4g, ±8g, ±16g
- 3 x 2.5 x 0.86 mm

Detection of movement, adjustment, shock and mechanical influence and stress, like bird pecking.

HUMIDITY & TEMPERATURE



WSEN-HIDS

- 16 bit humidity and temperature output
- I²C interface
- 1.5 x 1.5 x 0.5 mm

Environmental condition tracking like penetrating moisture.

WIREPAS



Thetis-I

- Wirepas routing mesh protocol, 2.4 GHz
- +6 dBm output power
- 8 x 12 x 2 mm

Meshing up a big number of devices without wiring effort.

CELLULAR



Adrastea-I

- LTE-NB.IoT / Cat.M1
- incl. GNSS
- 14 x 13 x 2 mm

Far distance maintenance access – remote control.

WIFI / BLUETOOTH



Stephano-I:

- Bluetooth® LE 5.0
- IEEE 802.11 b/g/n, 2.4 GHz
- 13 dBm output power
- 13 x 9.5 x 2 mm

Connect from smartphone or a WiFi network to the panel for taking into operation and as service interface.

IOT DESIGN KIT



- Available as WiFi (Calypso) and Cellular (Adrastea) Design Kit
- Tool for simple Cloud Connectivity Prototyping
- Send data to any cloud for further use
- Create real IoT use cases
- Examples and Sourcecode available on GitHub for Microsoft Azure and Amazon Web Services



INVERTER MONITORING



TRANSPARENT INVERTER CONDITION

In solar farms a permanently maintenance is required. This means to check the condition of the solar panels and inverters or to do some updates.

Würth Elektronik offers with the NB-IoT and LTE Cat. M connectivity the far distance management of the inverters, meaning remote monitoring and controlling, gives you either worldwide or locally enclosed access to your devices. In both cases highest security requirements can be fulfilled. If there is an firmware update for the inverter needed, this could be transferred via cellular too or via an service staff with Bluetooth in front of the inverter.

Benefits

- ✓ Wireless configuration of the inverter
- ✓ Easy installation and extension
- ✓ Save costs for condition monitoring
- ✓ Easy firmware updates

Industry

Mobility

Automation & Smart Home

Consumer

Energy

Medical

BLUETOOTH 



Proteus-III

- Bluetooth® LE 5.1
- Nordic nRF52840
- 8 dBm output power
- 12 x 8 x 2 mm

Connect from smartphone to the inverter to transfer data from and to the inverter

CELLULAR 



Adrastea-I

- LTE-NB.IoT / Cat.M1
- incl. GNSS
- 14 x 13 x 2 mm

Far distance maintenance access – remote control.

LONG-RANGE-WAN



Daphnis-I

- 868 MHz
- Supported long-range-WAN Classes A, B and C
- 15 x 16 x 3 mm

Connecting dozens or hundreds of systems to one gateway wirelessly.

RESIDUAL CURRENT 



WE-RCDS

- RDC-M module
- DC 6mA residual direct current detecting

Fault DC current detection in the system for fail-safe operation.

HUMIDITY & TEMPERATURE 



WSEN-HIDS

- 16 bit humidity and temperature output
- I²C interface
- 1.5 x 1.5 x 0.5 mm

Environmental condition tracking within the inverters. Recognizing exceptional conditions like penetrating moisture.

ACCELERATION 



WSEN-ITDS

- 3 axis acceleration
- 14 bit output resolution
- ±2g, ±4g, ±8g, ±16g
- 2 x 2 x 0.7 mm

Detection of shock and mechanical influence and stress, like bird pecking.

IOT DESIGN KIT 



- Available as WiFi (Calypso) and Cellular (Adrastea) Design Kit
- Tool for simple Cloud Connectivity Prototyping
- Send data to any cloud for further use
- Create real IoT use cases
- Examples and Sourcecode available on GitHub for Microsoft Azure and Amazon Web Services



TIME SYNCHRONIZED SAFETY LIGHTING



TIME SYNCHRONIZATION LIGHTING

Runway firing requires the highest reliable synchronized lighting. Reducing the wiring lowers installation costs and improves the degree of scalability.

Easy integration of new windmills into the existing park requires a reliable and secure bidirectional radio communication to increase Green Energy sector.

Würth Elektronik offers a variety of GNSS Moduls not only for localization but also for time synchronization. In combination with globally accepted radio standards like WiFi, Bluetooth, WE-ProWare, NB-IoT and LTE Cat. M the far distance management of machines, meaning remote monitoring and controlling, gives you dependend on the application either worldwide or locally enclosed access to your devices. In both cases highest security requirements can be fulfilled.

Predictive and curative maintenance can be triggered by intelligent digital sensors giving you the status of the environmental conditions in- and outside the housing and provides protection against natural destruction and exceptional failures.

Data can be made accessible through secure cloud connectivity.

Benefits

- ✓ Save kilometers of wiring
- ✓ Easy installation and extension
- ✓ Scalability
- ✓ Individual lights control
- ✓ Microsecond accuracy synchronization

CELLULAR & POSITIONING

Adrastea-I

- LTE-NB.IoT / Cat.M1
- incl. GNSS
- 14 x 13 x 2 mm

Far distance maintenance access – remote control.
Time Synchronization between different lights.
Time Stamping for Events.

PROPRIETARY

Setebos-I **Triton**

- Bluetooth® LE 5.1 & WE-ProWare 2.4 GHz
- 8 dBm output power
- 12 x 8 x 2 mm

- 2400 MHz
- RF Pad / PCB Antenna
- 14 dBm output power
- 27 x 17 x 3.8 mm

Proprietary for secure Mesh connection of the lighting network. Combined with Bluetooth for individual lighting configuration.

HUMIDITY & TEMPERATURE

WSEN-HIDS

- 16 bit humidity and temperature output
- I²C interface
- 1.5 x 1.5 x 0.5 mm

Environmental condition tracking within the lights. Recognizing exceptional conditions like penetrating moisture.

ACCELERATION

WSEN-ITDS

- 3 axis acceleration
- 14 bit output resolution
- ±2g, ±4g, ±8g, ±16g
- 2 x 2 x 0.7 mm

Detection of shock and mechanical influence and stress, like bird pecking.

IOT DESIGN KIT

- Available as WiFi (Calypso) and Cellular (Adrastea) Design Kit
- Tool for simple Cloud Connectivity Prototyping
- Send data to any cloud for further use
- Create real IoT use cases
- Examples and Sourcecode available on GitHub for Microsoft Azure and Amazon Web Services

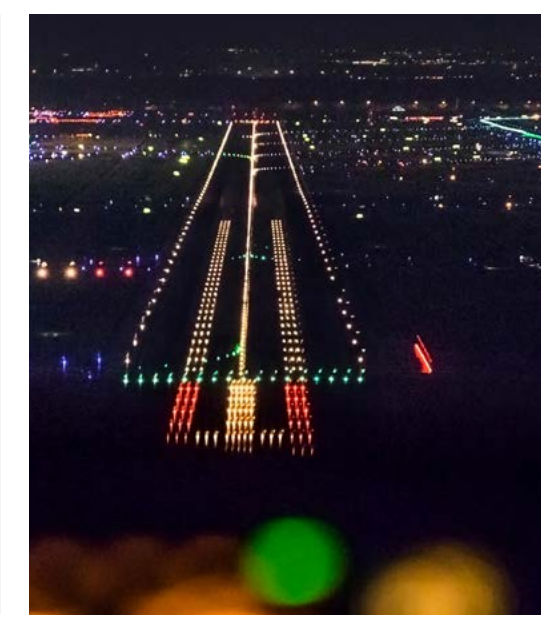



ENERGY & UTILITIES

GREEN ENERGY MONITORING – SMART GRID

It would be important in the power sector to be able to provide clean technology and embedded software solutions to reduce power consumption and costs, as well as retrofit monitoring for power line infrastructure and solar and weather station kits. The solutions then monitor power line fluctuations and deflections, as well as fire risk areas as fire detectors, and provide monitoring and smart city solutions for government agencies.

There is an exciting and rapidly changing atmosphere in the energy and utilities industry. The rapid adoption of new technologies, particularly communications-based technologies, is enabling them to better monitor, control and optimize every aspect of their business. There is no doubt that connectivity is the key to the smart grid. Wireless connectivity is enabling tomorrow's power plants and smart grids.

Wireless connectivity and network intelligence provide the ability to centrally monitor, self-regulate and respond to demand. Remote cameras and sensors reduce the need for on-site maintenance staff. Sensors enable near real-time diagnosis of expected and unexpected faults, enabling more accurate and faster fault location. Wireless connectivity provides reliable, accurate, and secure data from the field and offers cost and deployment advantages over competing technologies.

Benefits

- ✓ Real-time insights from the renewable asset
- ✓ Reduced downtime and increased asset life
- ✓ Improved operational efficiencies
- ✓ Make use of the 4 major applications in the electricity industry (Control Services, Collection Services, Mobile application services, New services of the power grid)

CELLULAR & POSITIONING

Adrastea-I

- LTE-NB.IoT / Cat.M1
- incl. GNSS
- 14 x 13 x 2 mm

Access to all monitoring and control data from anywhere in the world. Performing load balancing in the grid.

WIRELESS M-BUS

Metis-II

- 868 MHz
- RF Pad
- 14 dBm output power
- 27 x 17 x 3.8 mm

Sub-GHz radio communication with the wM-BUS EN13757 offers interoperability and reliability.

LONG-RANGE-WAN

Daphnis-I

- 868 MHz
- Supported long-range-WAN Classes A, B and C
- 15 x 16 x 3 mm

Long-range devices enable to install immediate prevention and control solutions in an established network.

HUMIDITY & TEMPERATURE

WSEN-HIDS

- 16 bit humidity and temperature output
- I²C interface
- 1.5 x 1.5 x 0.5 mm

Precise measuring the humidity & temperature at a specific point to avoid overheating and operating devices outside of the operational conditions.

ABSOLUTE PRESSURE

WSEN-PADS

- 26 – 126 kPa
- 260 – 1260 mbar
- 24 bit output resolution
- 2 x 2 x 0.8 mm

Barometric pressure is one of the environmental data which can forecast weather conditions.

TEMPERATURE

WSEN-TIDS

- Silicon based digital temperature sensor
- High accuracy (up to ±0.25 °C typ.)
- Fully calibrated 16 bit temperature output

Precise measuring the temperature at a specific point to avoid overheating and operating devices outside of the operational conditions

IOT DESIGN KIT

- Available as WiFi (Calypso) and Cellular (Adrastea) Design Kit
- Tool for simple Cloud Connectivity Prototyping
- Send data to any cloud for further use
- Create real IoT use cases
- Examples and Sourcecode available on GitHub for Microsoft Azure and Amazon Web Services



DIGITAL HEALTH & PREVENTION

CPAP MACHINE OR DIGITAL SPIROMETER

A CPAP machine is a machine that uses mild air pressure to keep breathing airways open while you sleep. The documentation process is very easy, if a wireless connection is established. Many people rely on such a machine and need medical support when evaluating the data. The current option of remote data transfer is a blessing, especially in rural areas with a low density of doctors.

With the well known radio standards like WiFi, NB-IoT and LTE Cat. M data can be simply transferred into a cloud system. Might this be a private solution or even a Cloud of a medical association with the highest security standards. Using the short range transfer capability of Bluetooth offers the patient the opportunity to evaluate the last night sleep on its own mobile device immediately in the morning.

For a digital spirometer in a handheld device size it is now possible to train the lung very well controlled at home. Expanding your lungs, strengthening your lungs, keeping your lungs inflated and clearing mucus and other secretions from your chest and lungs... all processes are precisely performed due to an App on your mobile device and a direct connection via Bluetooth. A well documented training progress is an added value as well.

Benefits

- ✓ Performing precise & well documented medical nurture
- ✓ Taking care of your health at home
- ✓ Use of the latest technologies by older people thanks to simple mobile apps

DIFFERENTIAL PRESSURE

WSEN-PDUS

- ± 100mbar
- ± 10 kPa
- 15 bit resolution
- 13 x 8 mm

Measurement and monitoring of inhaled and exhaled air.

HUMIDITY & TEMPERATURE

WSEN-HIDS

- 16 bit humidity and temperature output
- I²C interface
- 1.5 x 1.5 x 0.5 mm

Precise control of the humidity in the inhaled and exhaled air, but also of the environment to process the right amount of humidity.

CELLULAR & POSITIONING

Adrastea-I

- LTE-NB.IoT / Cat.M1
- incl. GNSS
- 14 x 13 x 2 mm

Transferring the measured data from any place in the world. Giving medical staff access to the machine to control or even adjust settings.

BLUETOOTH

Proteus-III

- Bluetooth® LE 5.1
- Nordic nRF52840
- 8 dBm output power
- 12 x 8 x 2 mm

Connect from mobile device like smartphone to the CPAP machine or mobile spirometer for mobile app access, control function and firmware updates.

BLUETOOTH

Proteus-e

- Bluetooth® LE 5.1
- Nordic nRF 52805
- 4dBm Output power
- 9 x 7 x 2 mm

Connect from mobile device like smartphone to the CPAP machine or mobile spirometer for mobile app access.

WIFI

Calypso

- IEEE 802.11 b/g/n, 2.4 GHz
- +18 dBm output power
- 19 x 27.5 x 4 mm

Integrate the CPAP machine into a local WiFi network for cloud connectivity and immediate data transfer and analytics like alarms.

IOT DESIGN KIT

- Available as WiFi (Calypso) and Cellular (Adrastea) Design Kit
- Tool for simple Cloud Connectivity Prototyping
- Send data to any cloud for further use
- Create real IoT use cases
- Examples and Sourcecode available on GitHub for Microsoft Azure and Amazon Web Services



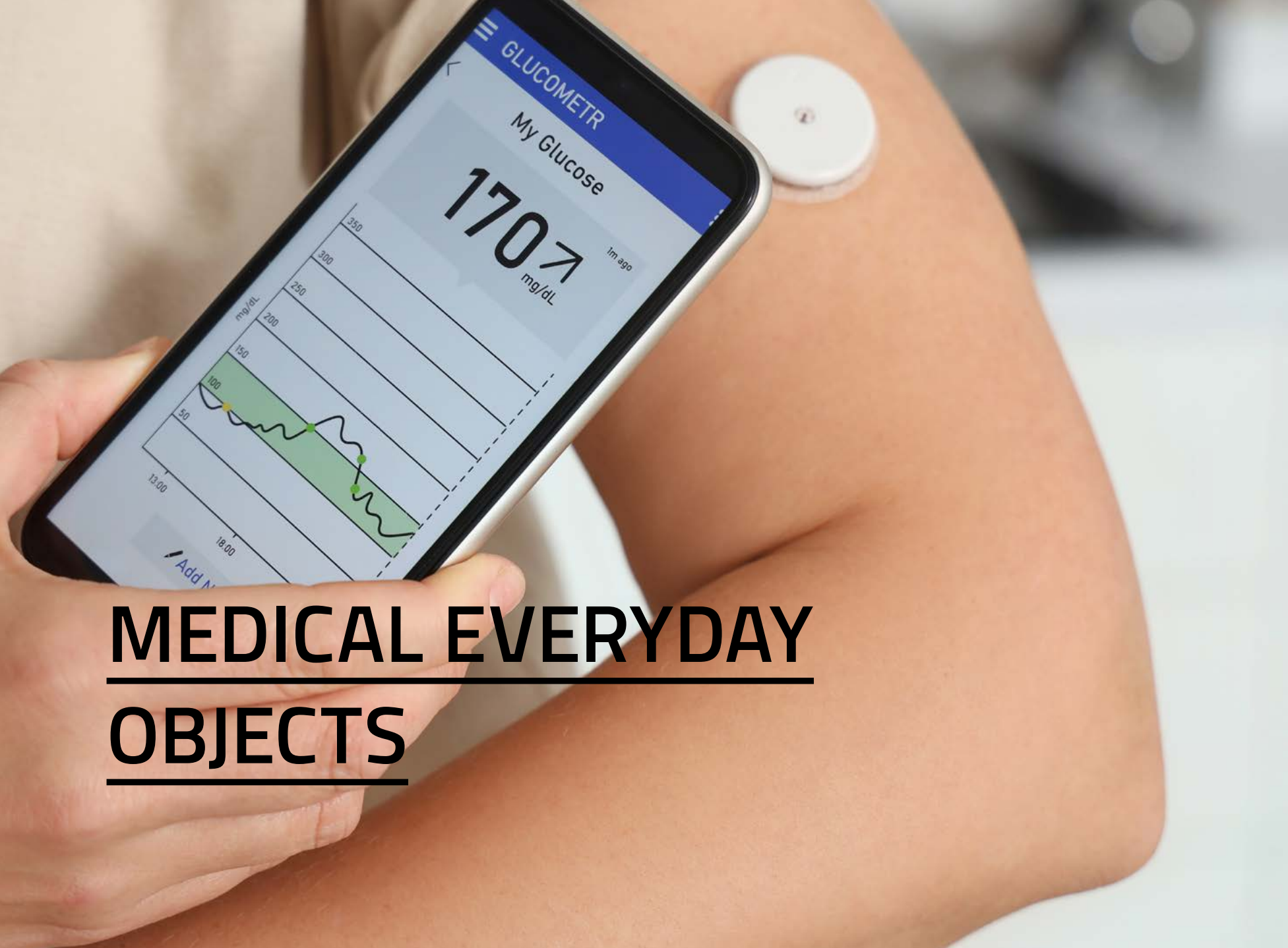

MEDICAL EVERYDAY OBJECTS

INTELLIGENT HOME AND MEDICAL APPLIANCES CAN IMPROVE PROCESSES EVERYWHERE

In medical environments a lot of processes have to be followed and documented correctly. Not rarely this means, that a well educated person has to do or document things, consuming a lot of time missing for the really important works to be done, mainly the time to care.

Würth Elektronik offers a variety of globally accepted radio standards like WiFi, Bluetooth, WE-ProWare, NB-IoT and LTE Cat. M the far distance management of devices, meaning remote monitoring and controlling, gives you dependend on the application either worldwide or locally enclosed access to your devices. In both cases highest security requirements can be fulfilled.

Predictive and curative maintenance can be triggered by intelligent digital sensors giving you the status of the environmental conditions in- and outside the housing and provides protection against natural destruction and exceptional failures. Data can be made accessible through secure cloud connectivity.

Benefits

- ✓ Saving time and money in care professions
- ✓ Improving data level
- ✓ Easy connectivity of formerly „stupid“ devices

GYRO

WSEN-ISDS

- 6 axis acceleration
- 16 bit output resolution
- ±2g, ±4g, ±8g, ±16g
- 3 x 2.5 x 0.86 mm

Detection of any movement, orientation and acceleration of the device.

HUMIDITY & TEMPERATURE

WSEN-HIDS

- 16 bit humidity and temperature output
- I²C interface
- 1.5 x 1.5 x 0.5 mm

Environmental condition tracking within the lights. Recognizing exceptional conditions like penetrating moisture.

CELLULAR & POSITIONING

Adrastea-l

- LTE-NB.IoT / Cat.M1
- incl. GNSS
- 14 x 13 x 2 mm

Far distance maintenance access – remote control and documentation obligation.

BLUETOOTH

Proteus-e

- Bluetooth® LE 5.1
- Nordic nRF 52805
- 4dBm Output power
- 9 x 7 x 2 mm

Connectivity as service interface and for provisioning.

IOT DESIGN KIT

- Available as WiFi (Calypso) and Cellular (Adrastea) Design Kit
- Tool for simple Cloud Connectivity Prototyping
- Send data to any cloud for further use
- Create real IoT use cases
- Examples and Sourcecode available on GitHub for Microsoft Azure and Amazon Web Services





LIFESTOCK MONITORING

HOOK STRAP FOR ANIMALS

In the course of more ecological and sustainable livestock farming it is necessary to monitor the environmental and health conditions of the animals.

Acceleration sensors and LTE mobile radio modules including localization (GNSS) by Würth Elektronik can be used to implement monitoring applications. In case the sensor system detects the movement pattern of an animal, an alarm signal will automatically be sent or predefined persons could be contacted if an abnormal behavior is detected. humidity sensors can be used to monitor the status of the environment.

WiFi modules can be integrated to connect the hook strap to the gateway Bluetooth LE To read out the measurements via smartphone. Data can be collected and finally send to the cloud using AWS or Azure.

Benefits

- ✓ Reduce costs for the veterinary and drugs
- ✓ Optimize the environmental conditions
- ✓ Minimizing the ecological impact
- ✓ Track the animals

HUMIDITY & TEMPERATURE



WSEN-HIDS

- 16 bit humidity and temperature output
- I²C interface
- 1.5 x 1.5 x 0.5 mm

To measure the environmental conditions.

ACCELERATION

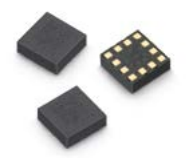

WSEN-ITDS

- 3 axis acceleration
- 14 bit output resolution
- ±2g, ±4g, ±8g, ±16g
- 2 x 2 x 0.7 mm

Activity tracking of the animal.

BLUETOOTH



Proteus-III

- Bluetooth® LE 5.1
- Nordic nRF52840
- 8 dBm output power
- 12 x 8 x 2 mm

Connect from smartphone to the hook strap to transfer datas from the cow.

LONG-RANGE-WAN



Daphnis-I

- 868 MHz
- Supported long-range-WAN Classes A, B and C
- 15 x 16 x 3 mm

Costeffective connection of dozens or hundrets of sensors to one gateway.

CELLULAR & POSITIONING



Adrastea-I

- LTE-NB.IoT / Cat.M1
- incl. GNSS
- 14 x 13 x 2 mm

Cloud connection for datas and alarm and localization of the cow.

WIFI



Calypso

- IEEE 802.11 b/g/n, 2.4 GHz
- +18 dBm output power
- 19 x 27.5 x 4 mm

Cloud connection for datas and alarm.

IOT DESIGN KIT



Available as WiFi (Calypso) and Cellular (Adrastea) Design Kit

- Tool for simple Cloud Connectivity Prototyping
- Send data to any cloud for further use
- Create real IoT use cases
- Examples and Sourcecode available on GitHub for Microsoft Azure and Amazon Web Services

HIGHLY SPECIALIZED MACHINES FOR MEDICAL APPLICATIONS

New and better materials make it possible to produce increasingly robust, lighter and more durable prostheses and implants. The manufacturing and processing of these materials makes new processing methods necessary again and again.

All moving machines like mills, lathes and CNC need an exact position and movement feedback. This could be realized with 6-Axis MEMS-Sensors from Würth Elektronik.

Pneumatic controls need to be measured with high accuracy, i.e. with differential Pressure Sensors based on MEMS principles. These sensors are very accurate, temperature compensated and factory calibrated.

To get access to working machines without stopping automatised processes, the service technician could connect wirelessly via Bluetooth or WiFi to the machine to read out running hours or fill levels or for calibrating the machine.

Benefits

- ✓ Save complex wiring
- ✓ Easy service interface
- ✓ Accurate sensing
- ✓ Temperature compensation
- ✓ Factory calibrated sensors

MEDICAL MILL



GYRO 

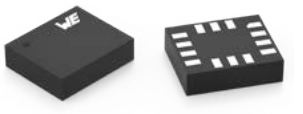

WSEN-ISDS

- 6 axis acceleration
- 16 bit output resolution
- ±2g, ±4g, ±8g, ±16g
- 3 x 2.5 x 0.86 mm

Detection of any movement, orientation and acceleration of the device.

DIFFERENTIAL PRESSURE 



WSEN-PDUS

- ± 100mbar
- ± 10 kPa
- 15 bit resolution
- 13 x 8 mm

Sensing the pneumatic pressure inside the mill.

ADAPTER



WSEN-PDUS-Adapter

Connecting WSEN-PDUS with standard 6 mm tubes..

BLUETOOTH 



Proteus-e

- Bluetooth® LE 5.1
- Nordic nRF 52805
- 4dBm Output power
- 9 x 7 x 2 mm

Connectivity as service interface and for provisioning.

WIFI 



Calypso

- IEEE 802.11 b/g/n, 2.4 GHz
- +18 dBm output power
- 19 x 27.5 x 4 mm

Cloud connection for data and alarm.

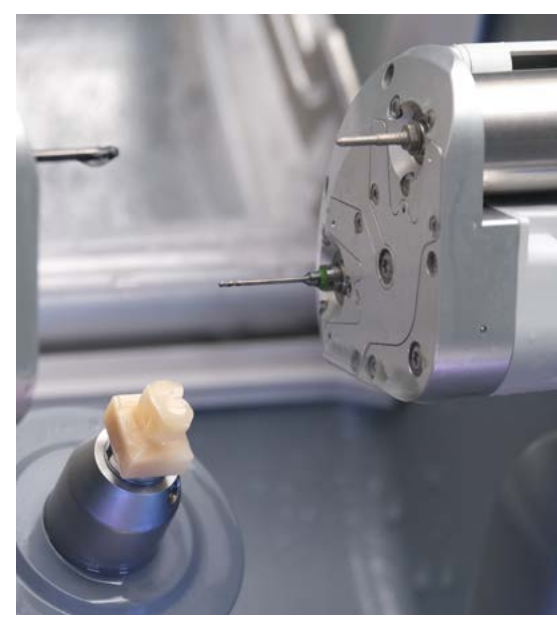

WÜRTH ELEKTRONIK MORE THAN YOU EXPECT



CREATING IDEAS

