

TI Designs: TIDA-01386

Ultrasonic Distance Sensor With IO-Link Reference Design



Description

This reference design features an ultrasonic distance sensor that fits in a M12 housing due to its high integration and an optimized layout. The design offers an IO-Link interface to communicate with the system control, which makes it industry 4.0 ready.

The purpose of ultrasonic sensors is to detect or measure distances of an object independently from their color, transparency, or surface characteristics and from the surrounding environment. Ultrasonic sensors are able to function in harsh environments such as factories and process plants.

Resources

TIDA-01386	Design Folder
PGA460	Product Folder
TIOL111	Product Folder
LM5166	Product Folder
MSP439FR5959	Product Folder
TVS3300	Product Folder

Features

- Small Form Factor: M12
- IO-Link Interface
- Distance Range: 10 cm to 30 cm (300 kHz); 30 cm to 5 m (58 kHz)
- Resolution: Approximately 1 mm (300 kHz); Approximately 1 cm (58 kHz)
- Non-Contact Detection and Measurement

Applications

- [Displacement Transmitter](#)
- [Level Transmitter](#)
- [Logistic Robots](#)
- [Industrial Robots](#)
- [Drones](#)



[ASK Our E2E Experts](#)

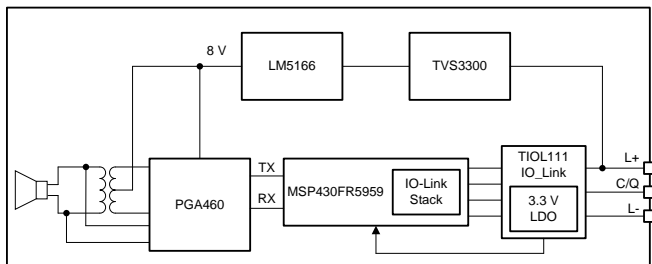

Copyright © 2017, Texas Instruments Incorporated

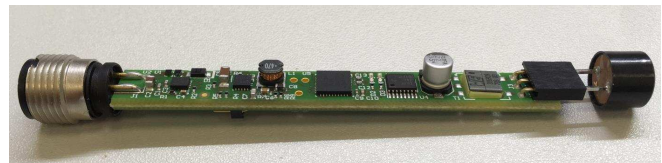

An IMPORTANT NOTICE at the end of this TI reference design addresses authorized use, intellectual property matters and other important disclaimers and information.

1 System Description

The use of ultrasonic technology in industrial and automotive applications is extensive. In the industry, use of ultrasonic technology is prevalent in flow and level transmitters (process automation) and displacement transmitters (factory automation).

Ultrasonic sensors transmit and receive sound waves in the ultrasonic range. The measurement principle is based on the time of flight (ToF), which is the time that an ultrasonic waveform takes to travel back and forward from the sensor to the target.

A piezoelectric transducer is a key element of an ultrasonic sensor since it is the object responsible for converting an electric signal to an acoustic signal, which then travels through a medium, hits the target, and travels back to the piezo. The piezo then converts the acoustic signal back to an electrical signal.

The programmable gain amplifier (PGA) drives and reads the piezoelectric transducer due to its integrated transducer driver and a signal conditioner with an advanced digital signal processing (DSP) core.

The TIOL111 transceiver handles the communication. The TIOL111 is a transceiver that implements the IO-Link interface for industrial, bidirectional, point-to-point communication, thus making the TIDA-01386 ready for Industry 4.0.

1.1 Key System Specifications

Table 1. Key System Specifications

PARAMETER	SPECIFICATIONS	DETAILS
Communication interface	IO-Link	Section 2.2.2
Transducer type	MA58MF14-7N; MA300D1-1	Section 2.3
Transducer frequency	58 kHz (MA58MF14-7N); 300 kHz (MA300D1-1)	Section 2.3
Sensing range	10 cm to 30 cm (300 kHz); 30 cm to 5 m (58 kHz)	Section 4
Resolution	~1mm(300kHz); ~1 cm (58kHz)	Section 4
Form factor	M12 (76 mm × 8.9 mm)	Section 3.1

2 System Overview

2.1 Block Diagram

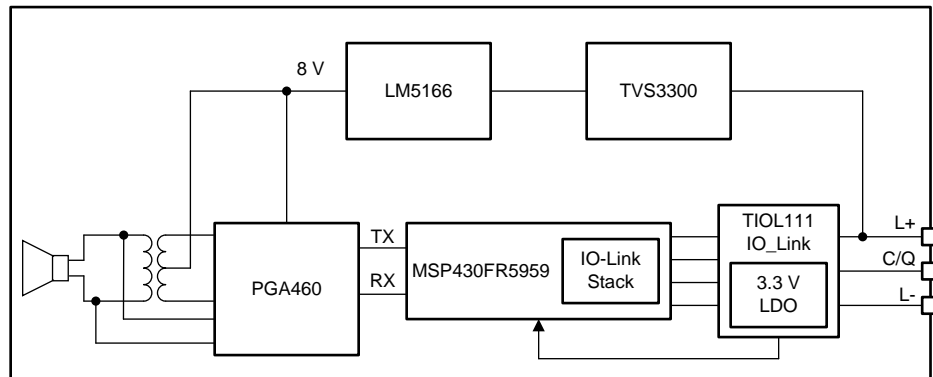

Copyright © 2017, Texas Instruments Incorporated

Figure 1. TIDA-01386 Block Diagram

2.2 Highlighted Products

2.2.1 PGA460

The PGA460 device is a highly-integrated, system-on-chip (SoC) ultrasonic transducer driver and signal conditioner with an advanced DSP core. The device has a complimentary low-side driver pair that can drive a transducer either in a transformer-based topology using a step-up transformer or in a direct-drive topology using external high-side field-effect transistors (FETs). The device can receive and condition the reflected echo signal for reliable object detection. Accomplish this feature by using an analog front end (AFE) consisting of a low-noise amplifier followed by a programmable time-varying gain stage feeding into an analog-to-digital converter (ADC). The digitized signal is processed in the DSP core for both near-field and far-field object detection using time-varying thresholds. Establish the main communication with an external controller by using either a time-command interface (TCI) or a one-wire universal synchronous and asynchronous receiver-transmitter (USART) interface on the IO pin, or a CMOS-level USART interface on the RXD and TXD pins. The PGA460 can be put in ultra-low quiescent current low-power mode to reduce power consumption when not in use and can be woken up by commands on the communication interfaces. The PGA460 also includes on-chip system diagnostics which monitor transducer voltage during the burst, frequency, and decay time of a transducer to provide information about the integrity of the excitation as well as supply-side and transceiver-side diagnostics for overvoltage, undervoltage, overcurrent, and short-circuit scenarios.

Figure 2 shows the PGA460 block diagram.

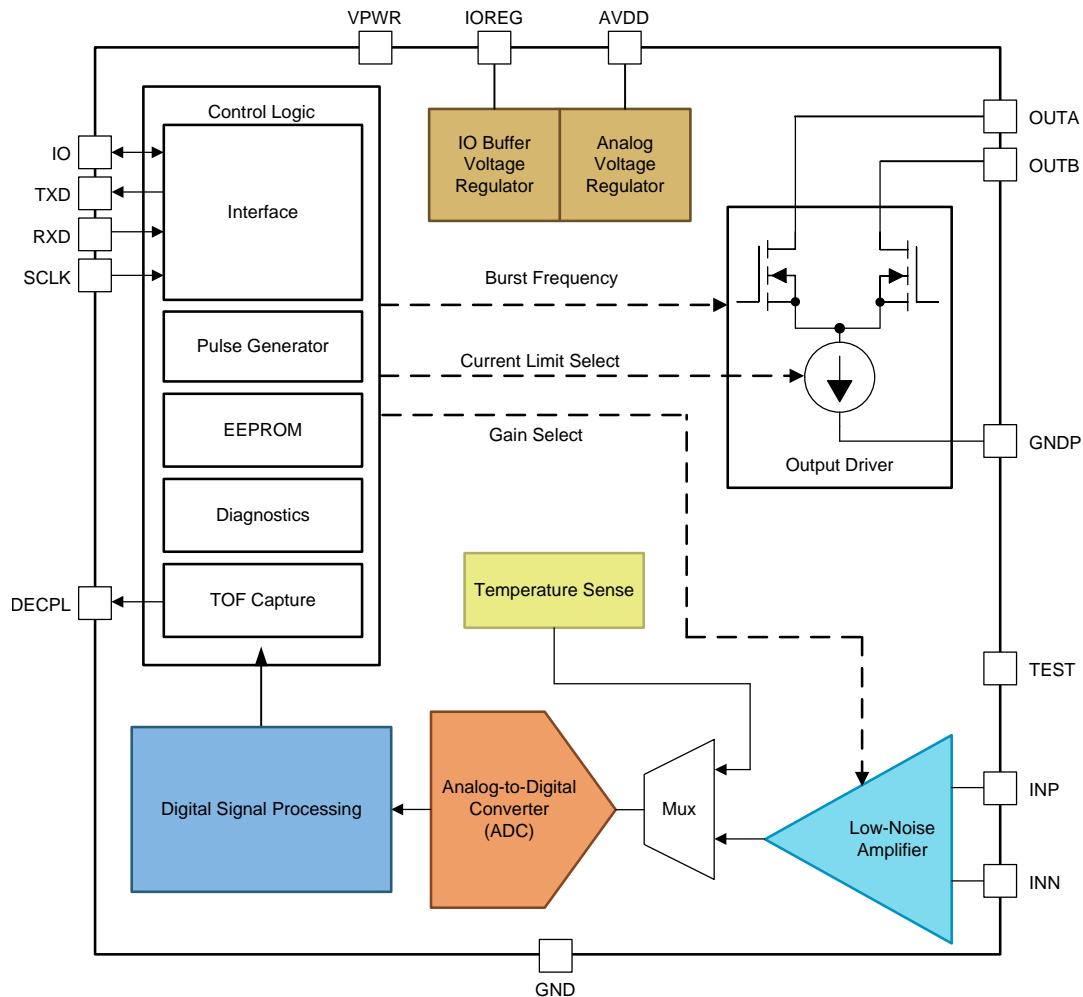

Copyright © 2017, Texas Instruments Incorporated

Figure 2. PGA460 Block Diagram

The key features of this device are:

- Fully integrated solution for ultrasonic sensing
- Complimentary low-side drivers with configurable current limit supporting both transformer-based and direct-drive-based topologies for transducer excitation
- Single transducer for both burst and listen; or a transducer pair: one for burst and other for listen operation
- Low-noise receiver with programmable, six-point time-varying gain (32 to 90 dB) with DSP (BPF, demodulation) for echo envelope detection
- Two presets of 12-point time-varying threshold for object detection
- Timers to measure distance and duration of multiple echos
- Integrated temperature sensor
- Record time for object detection up to 11 m
- 128 bytes of RAM for echo recording
- 42 bytes of user EEPROM to store configuration for fast initialization
- One-wire high-voltage time-command interface or USART interface
- CMOS-level USART interface
- Sensor diagnostics (decay frequency and time, excitation voltage), supply, and transceiver diagnostics

2.2.2 TIOL111

The robust TIOL111 family of transceivers implements the IO-Link interface for industrial point-to-point communication. These devices are capable of withstanding up to 1 kV (500 Ω) of IEC 61000-4-5 surge and feature integrated reverse-polarity protection. A simple pin-programmable interface allows easy interfacing to the controller circuits. The user can configure the output current limit using an external resistor. Fault reporting and internal protection functions are provided for undervoltage, short-circuit current, and overtemperature.

Figure 3 TIOL111 block diagram.

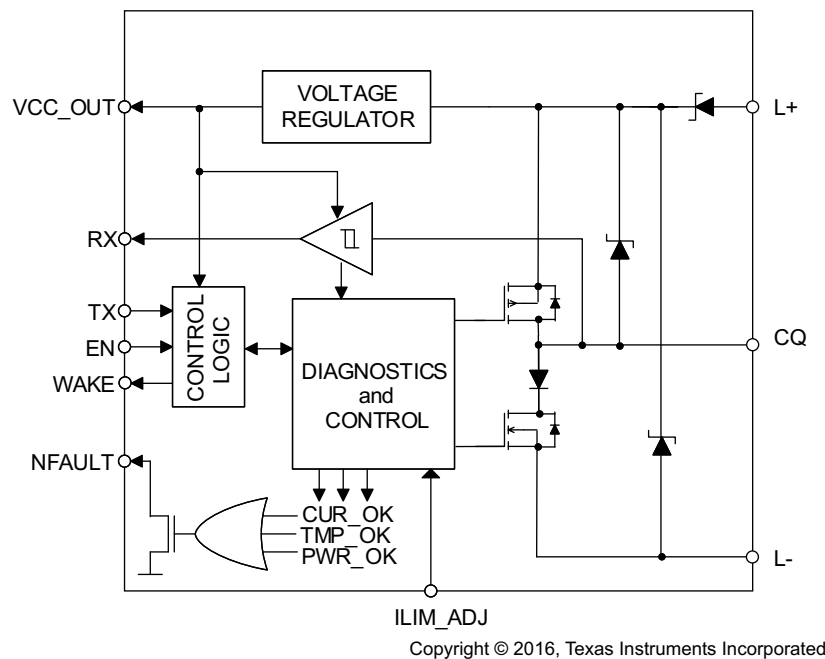

Figure 3. TIOL111 Block Diagram

The key features of this device are:

- 7- to 36-V supply voltage
- PNP, NPN, or IO-Link configurable output
- IEC 61131-9 COM1, COM2, and COM3 data-rate support
- Low residual voltage of 1.75 V at 250 mA
- 50-mA to 350-mA configurable current limit
- Tolerant to ± 65 -V transients < 100 μ s
- Reverse polarity protection of up to 55 V on L+, CQ, and L-
- Integrated electromagnetic compatibility (EMC) protection on L+ and CQ:
 - ± 16 -kV IEC 61000-4-2 ESD Contact Discharge
 - ± 4 -kV IEC 61000-4-4 Electrical Fast Transient
 - ± 1.2 -kV/500- Ω IEC 61000-4-5 Surge
- Fast demagnetization of inductive loads up to 1.5 H
- Large capacitive load-driving capability
- < 2- μ A CQ leakage current
- < 1.5-mA quiescent supply current
- Integrated low-dropout linear regulator (LDO) options for up to 20-mA current:
 - TIOL111: No LDO
 - TIOL111-3: 3.3-V LDO

- TIOL111-5: 5-V LDO
- Overtemperature warning and thermal protection
- Remote wake-up indicator
- Fault indicator
- Extended ambient temperature: -40°C to 125°C
- 2.5x3.0-mm, 10-pin VSON package

2.2.3 LM5166

The LM5166 is a compact, easy-to-use, 3-V to 65-V, ultra-low I_Q synchronous buck converter with high efficiency over wide input voltage and load current ranges. With integrated high-side and low-side power MOSFETs, the device is capable of delivering up to 500 mA of output current at fixed output voltages of 3.3 V or 5 V, or an adjustable output. The design of the converter simplifies implementation while providing options to optimize the performance for the target application. Pulse frequency modulation (PFM) mode is selected for optimal light-load efficiency or constant on-time (COT) control for nearly-constant operating frequency. Both control schemes do not require loop compensation while providing excellent line and load transient response and short PWM on-time for large step-down conversion ratios. The high-side P-channel MOSFET can operate at a 100% duty cycle for the lowest dropout voltage and does not require a bootstrap capacitor for gate drive. Also, the current limit setpoint is adjustable to optimize inductor selection for a particular load current requirement. Selectable and adjustable start-up timing options include minimum delay (no soft start), internally fixed (900 μs), and externally-programmable soft start using a capacitor. An open-drain PGOOD indicator can be used for sequencing, fault reporting, and output voltage monitoring. The LM5166 is available in a 10-pin VSON package with 0.5-mm pin pitch.

[Figure 4](#) shows the LM5166 block diagram.

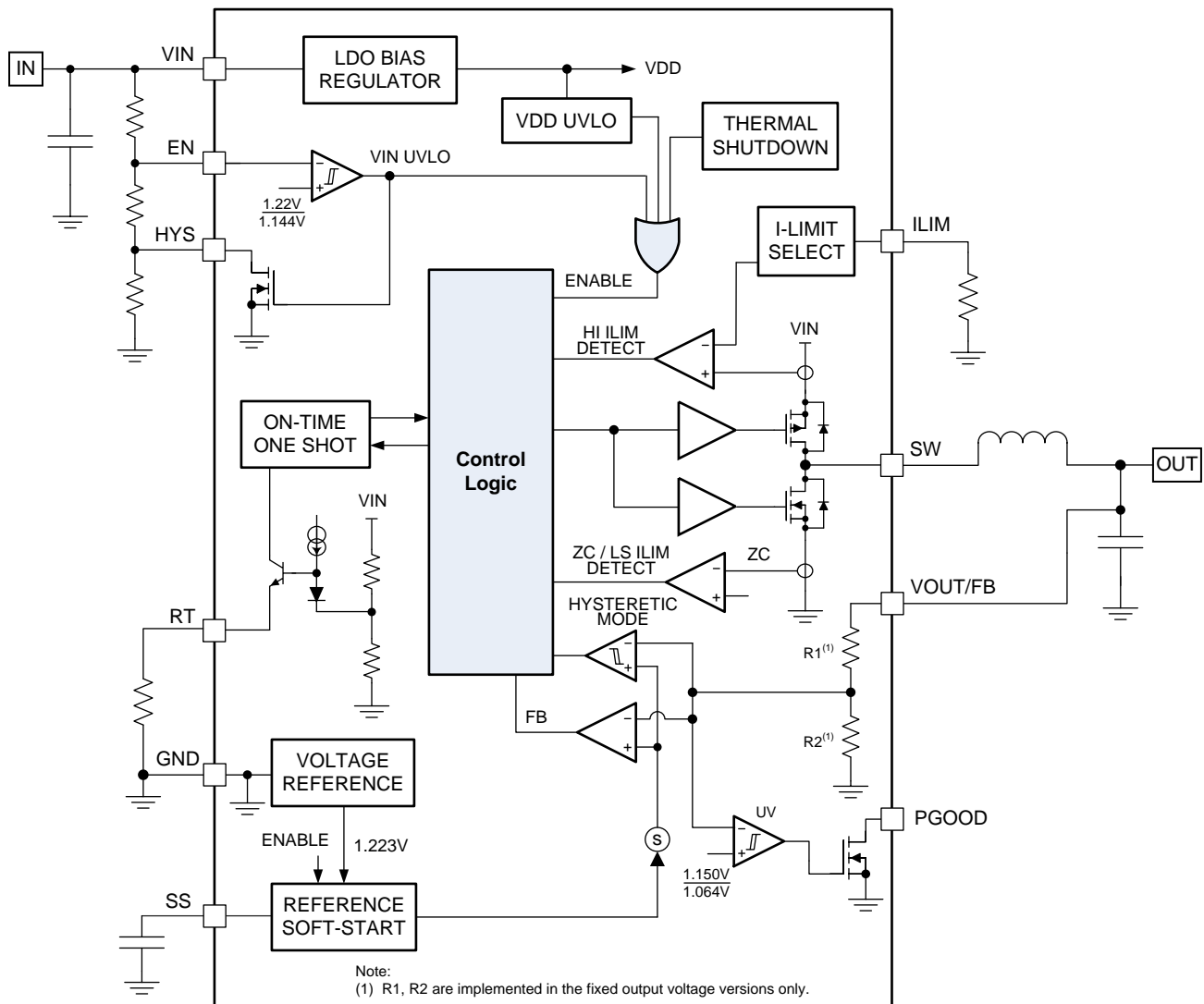

Copyright © 2016, Texas Instruments Incorporated

Figure 4. LM5166 Block Diagram

The key features of this device are:

- Wide input voltage range of 3 V to 65 V
- 9.7- μ A no-load quiescent current
- -40°C to 150°C junction temperature range
- Fixed (3.3-V, 5-V) or adjustable V_{OUT} options
- Meets EN55022 / CISPR 22 electromagnetic interference (EMI) standards
- Integrated 1- Ω PFET buck switch
 - Supports 100% duty cycle for low dropout
- Integrated 0.5- Ω NFET synchronous rectifier
 - Eliminates external Schottky diode
- Programmable peak current limit supports:
 - 500-mA, 300-mA, or 200-mA loads
- Selectable PFM or COT mode operation
- 1.223-V \pm 1.2% internal voltage reference

- Switching frequency up to 600 kHz
- 900- μ s internal or externally-adjustable soft start
- Diode emulation and pulse skipping for ultra-high light-load efficiency
- No loop compensation or bootstrap components
- Precision enable and input undervoltage lockout (UVLO) with hysteresis
- Open-drain power good indicator
- Thermal shutdown protection with hysteresis
- Pin-to-pin compatible with LM5165
- 10-pin, 3-mm \times 3-mm VSON package
- Create custom regulator design using WEBENCH[®] Power Designer

2.2.4 MSP430FR5959

The Texas Instruments MSP430[™] family of ultra-low-power microcontrollers (MCUs) consists of several devices that feature different combinations of peripherals targeted for various applications. Combined with extensive low-power modes, the architecture is optimized to achieve extended battery life in portable measurement applications. The MSP430 MCU features a powerful 16-bit RISC CPU, 16-bit registers, and constant generators that contribute to maximum code efficiency. The digitally controlled oscillator (DCO) allows the MCU to wake up from low-power modes to active mode typically in less than 10 μ s.

Figure 5 shows the MSP430FR5959 block diagram.

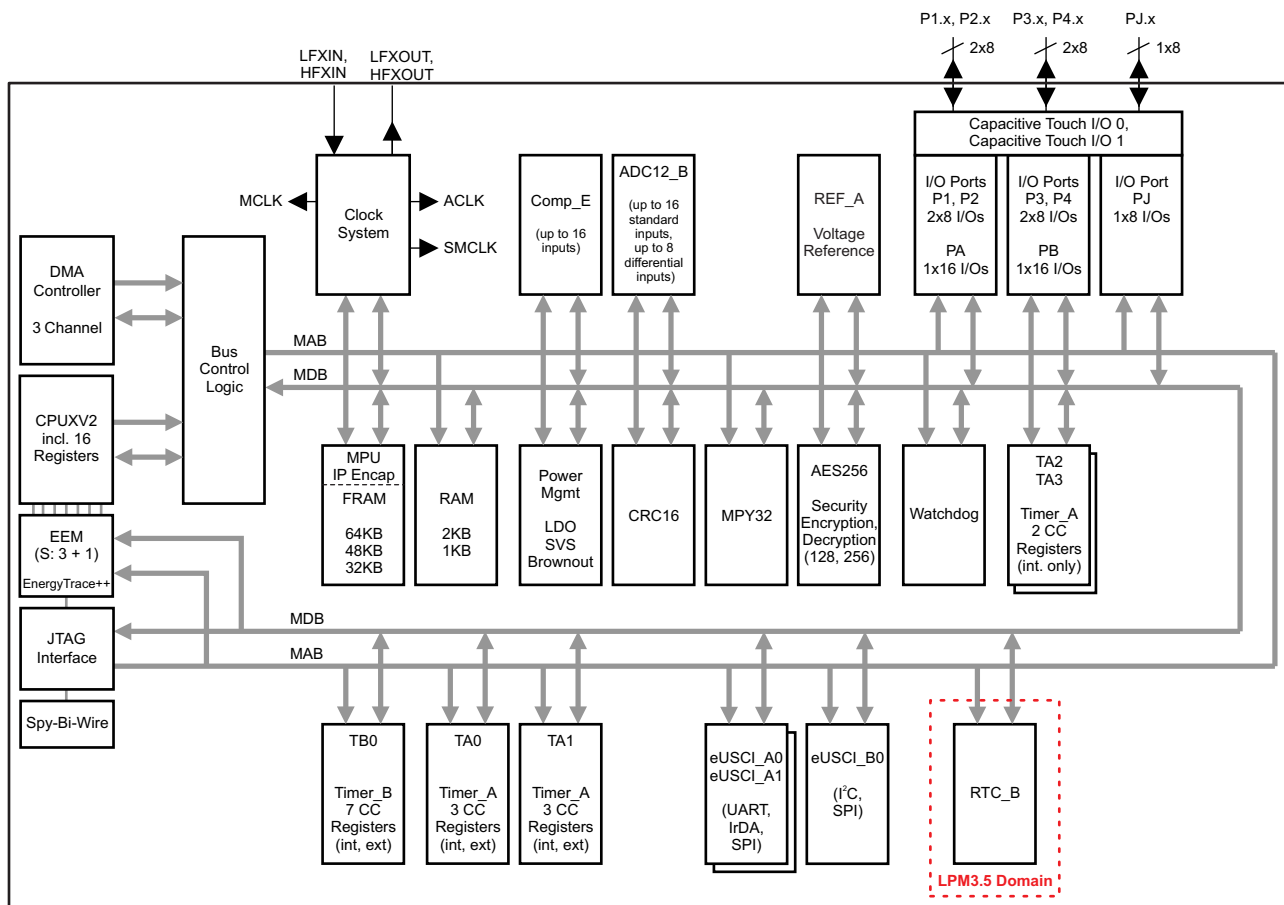

Copyright © 2016, Texas Instruments Incorporated

Figure 5. MSP430FR5959 Block Diagram

The key features of this device are:

- Embedded microcontroller:
 - 16-bit RISC architecture up to 16-MHz clock
 - Wide supply voltage range (1.8 to 3.6 V)
- Optimized ultra-low-power modes:
 - Active mode: Approximately 100 $\mu\text{A}/\text{MHz}$
 - Standby (LPM3 with VLO): 0.4 μA (typical)
 - Real-time clock (RTC; LPM3.5): 0.25 μA (typical)
 - Shutdown (LPM4.5): 0.02 μA (typical)
- Ultra-low-power FRAM:
 - Up to 64KB of nonvolatile memory
 - Ultra-low-power writes
 - Fast write at 125 ns per word (64KB in 4 ms)
 - Unified memory = program + data + storage in one single space
 - 10¹⁵ write cycle endurance
 - Radiation resistant and nonmagnetic
- Intelligent digital peripherals:
 - 32-bit hardware multiplier (MPY)
 - Three-channel internal DMA
 - RTC with calendar and alarm functions
 - Five 16-bit timers with up to seven capture and compare registers each
 - 16-bit cyclic redundancy checker (CRC)
- High-performance analog:
 - 16-channel analog comparator
 - 12-bit ADC with internal reference and sample-and-hold and up to 16 external input channels
- Multifunction input and output ports:
 - All pins support capacitive touch capability with no requirement for external components
 - Accessible bit-, byte-, and word-wise (in pairs)
 - Edge-selectable wake from LPM on all ports
 - Programmable pullup and pulldown on all ports
- Code security and encryption:
 - 128-bit or 256-bit AES security encryption and decryption coprocessor
 - Random number seed for random number generation algorithms
- Enhanced serial communication:
 - eUSCI_A0 and eUSCI_A1 support:
 - UART with automatic baud-rate detection
 - IrDA encode and decode
 - Serial peripheral interface (SPI) at rates up to 10 Mbps
 - eUSCI_B0 supports:
 - I²C with multiple slave addressing
 - SPI at rates up to 8 Mbps
 - Hardware UART and I²C bootstrap loader (BSL)
- Flexible clock system:
 - Fixed-frequency DCO with ten selectable factory-trimmed frequencies
 - Low-power, low-frequency internal clock source (VLO)

- 32-kHz crystals (LFXT)
- High-frequency crystals (HFXT)

For complete module descriptions, see [MSP430FR58xx, MSP430FR59xx, and MSP430FR6xx Family \(SLAU367\)](#).

2.2.5 TVS3300

The TVS3300 is a transient voltage suppressor (TVS) which provides robust protection for electronic circuits exposed to high-transient voltage events. Unlike a traditional TVS diode, the TVS3300 precision clamp triggers at a lower breakdown voltage and regulates to maintain a flat clamping voltage throughout a transient overvoltage event. The lower clamping voltage combined with a low dynamic resistance enables a unique TVS protection solution that can lower the voltage of a system to which it is exposed during a surge event by up to 30% in unidirectional configuration and up to 20% in bidirectional configuration when compared to traditional TVS diodes. The low clamping voltage and flat clamping performance allow designers to confidently select downstream system components with the maximum voltage rating than is possible with traditional TVS diodes, which provides savings to system costs, increases the board area, and improves the overall performance.

The TVS3300 is a unidirectional, precision-surge protection clamp with a 33-V working voltage which has been specifically designed to protect systems with mid-voltage rails in industrial, communication, and factory automation applications. The TVS3300 has a fast response time when surge current is applied so there is no overshoot voltage during clamping, making it ideal to replace traditional TVS and Zener diodes.

The TVS3300 is available in two small-footprint packages which, when used in place of an industry standard SMB package, can reduce the footprint by 94% (WCSP package) and 79% (SON package) for space-constrained applications. Both package options robustly dissipate the surge power and provide up to 58% lower leakage current as compared to traditional TVS diodes in SMA and SMB packages, allowing for higher accuracy 4–20-mA current loop measurements.

Figure 6 shows the TVS3300 system diagram.

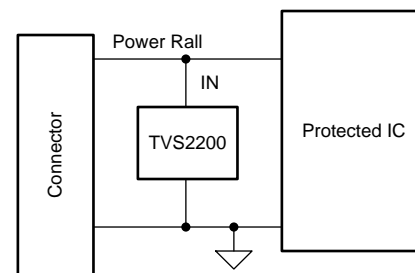

Copyright © 2017, Texas Instruments Incorporated

Figure 6. TVS3300 System Diagram

The key features of this device are:

- Ultra-low and flat clamping voltage
 - 38 V at 35 A (8/20 μ s)
 - R_{DYN} : 40 m Ω
- Standoff voltage: 33 V
- Low leakage current
 - 19 nA at 27°C
 - 28 nA at 85°C
- Peak pulse power:
 - 1330 W (8/20 μ s)
 - 150 W (10/1000 μ s)
- IEC 61000-4-2 Level 4 ESD Protection
 - \pm 14-kV Contact Discharge

- ±11-kV Contact Discharge (SON)
- ±30-kV Air Gap Discharge
- IEC 61000-4-4 EFT Protection
 - 80 A (5/50 ns)
- IEC 61000-4-5 Surge Protection
 - 35 A (8/20 μ s)
- Industrial temperature range: –40°C to +125°C
- Compact packages
 - 4-pin WCSP package (1.062 mm × 1.116 mm)
 - 6-pin SON package (2 mm × 2 mm)

2.3 Design Considerations

The PGA460 device must be paired with an external transducer. The user must choose an external transformer or p-channel MOSFET that meets the input voltage requirements of the transducer and has a saturation current rated equal to or greater than the configured driving current limit of the PGA460 device.

This reference design is tested with the MA58MF14-7N and MA300D1-1 transducers from Murata with the following specifications (see [Table 2](#) and [Table 3](#)); however, the designer can connect any transducer to the board.

Table 2. MA300D1-1 Specifications

PARAMETER	SPECIFICATIONS
Operating temperature range	–20°C to 70°C
Construction	High frequency type
Center frequency	300 kHz
Overall sensitivity	1.5~4.0 $V_{p,p}$
Directivity	5deg.(Reference Value)
Capacitance	1300 pF
Capacitance tolerance	±20%
Maximum input voltage	50 $V_{p,p}$ Drive wave number: five cycles, Drive cycle: 300 Hz

Table 3. MA58MF14-7N Specifications

PARAMETER	SPECIFICATIONS
Operating temperature range	–20°C to 85°C
Construction	Waterproof type
Center frequency	58 kHz
Overall sensitivity	More than 1 V_{OP}
Directivity	80° x 35° (typical)
Capacitance	1400 pF
Capacitance tolerance	±20%
Maximum input voltage	120- $V_{p,p}$ pulse number: 20 pulses or less interval: 20 ms or more. Do not apply DC voltage.

The transformer-driven method has been chosen for the TIDA-01386 design based on these specifications and the fact that both transducers are closed-top transducers. Figure 7 shows a schematic of the transformer-driven method.

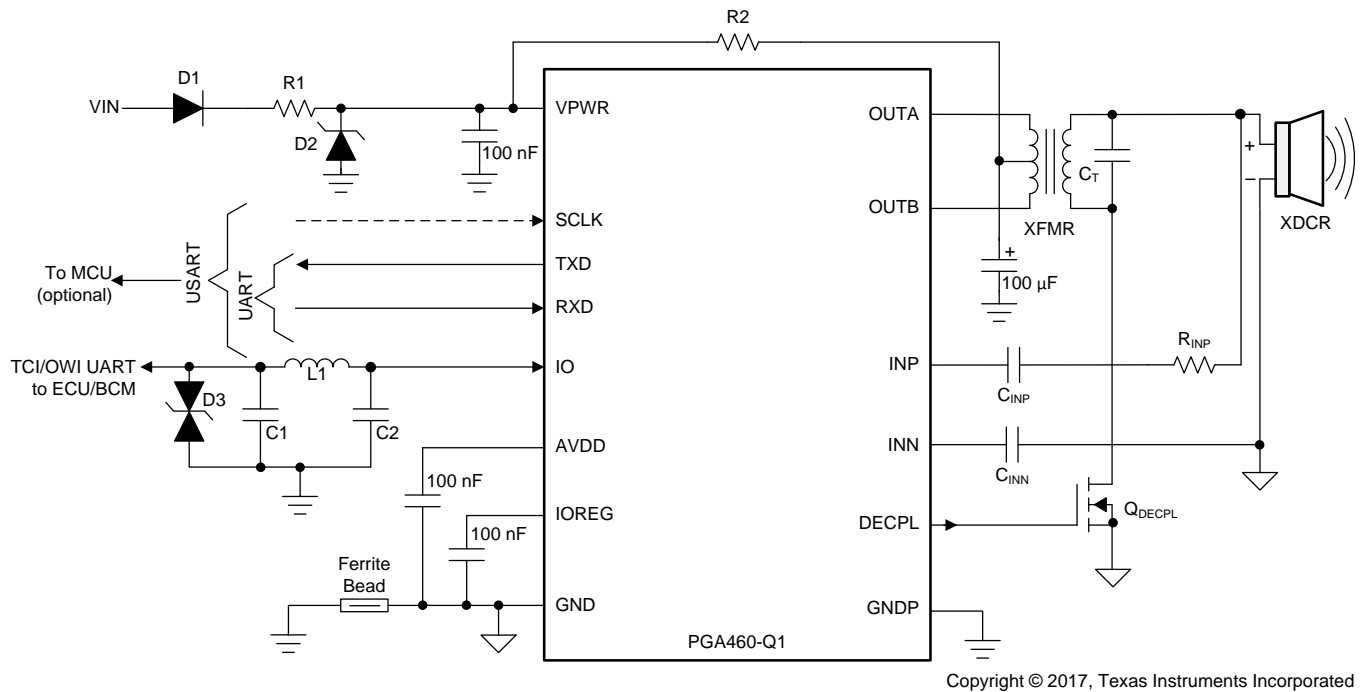

Figure 7. Schematic for Transformer-Driven Method

A center-tap transformer is typically paired with the transducer to convert a DC voltage to a high-sinusoidal AC voltage. The center tap is a contact which is located halfway along the primary winding of the transformer. The center tap is supplied with the DC voltage, which is then multiplied on the secondary side based on the turns ratio of the transformer. Figure 8 shows a typical pinout of a center-tap transformer where pin 2 is the center tap, pins 1 and 3 are connected to OUTB and OUTA, pin 4 is connected to the positive terminal of the transducer, and pin 6 is connected to ground.

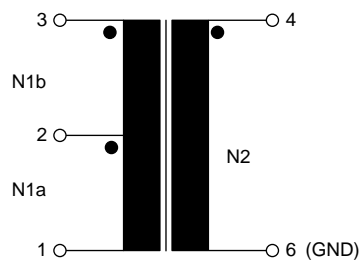

Figure 8. Typical Pinout of Center-Tap Transformer for Ultrasonic Transducers

To generate the transducer voltage using the center-tap transformer, use a push-pull mode where the two internal low-side switches of the PGA460 device are used to turn the current ON and OFF in two primary coils of the center-tap transformer. The primary coils have the same number of turns. The rate of change of current in the primary coil generates a voltage in the secondary coil of the transformer, which is connected to the transducer. The direction of current in the primary coils generates voltages of opposite polarity in the secondary coils, which effectively doubles the peak-to-peak voltage in the secondary coil.

The B78416A2232A003 and 750317161 transformers are used to drive the MA58MF14-7N transducer. [Table 4](#) and [Table 5](#) list some of the technical data for the B78416A2232A003 and 750317161 transformers.

Table 4. Technical Data B78416A2232A003

PARAMETER	SPECIFICATIONS
Main inductance L (4 – 6)	3 mH (52 kHz, 1 V, +25°C)
Inductance tolerance	±10% at +25°C
Turns ratio	1 : 1 : 8.42
Operating frequency f	52 kHz
Test voltage V_{TEST}	200-V AC
Operating temperature range	–40°C ... +85°C

Table 5. Technical Data 750317161

PARAMETER	SPECIFICATIONS
Main inductance L (4 – 6)	3 mH (58 kHz, 1 V, +25°C)
Inductance tolerance	±10% at +25°C
Turns ratio	1 : 1 : 8.42
Operating frequency f	58 kHz
Test voltage V_{TEST}	200-V AC 1 min
Operating temperature range	–40°C ... +125°C

The B78416A2386A003 and 750316928 has been used to drive the MA300D1-1 transducer. [Table 6](#) and [Table 7](#) list some of the technical data for the B78416A2386A003 and 750316928 transformers.

Table 6. Technical Data B78416A2386A003

PARAMETER	SPECIFICATIONS
Main inductance L (4 – 6)	0.23 mH (50 kHz, 100 mV, +25°C)
Inductance tolerance	±8% at +25°C
Turns ratio	1 : 1 : 9
Operating frequency f	300 kHz
Test voltage V_{TEST}	200-V AC
Operating temperature range	–40°C ... +85°C

Table 7. Technical Data 750316928

PARAMETER	SPECIFICATIONS
Main inductance L (4 – 6)	0.24 mH (10 kHz, 100 mV, +25°C)
Inductance tolerance	±8% at +25°C
Turns ratio	1 : 1 : 9
Operating frequency f	300 kHz
Test voltage V_{TEST}	500-V AC 1 min
Operating temperature range	–40°C ... +125°C

If the designer selects a different transducer, then they must also select a different transformer.

[Table 8](#) lists the recommended component values for the TIDA-01386 reference design.

Table 8. Recommended Component Values for PGA460

DESIGNATOR	VALUE	COMMENTS
R2	100 Ω	Limit in-rush current
R _(INP)	100 Ω	For EMI and ESD robustness
C _(INP)	$C_{(INP)} = 21.22 \times 10^{-6} f(\text{TRANSDUCER}) = 75 \text{ pF}$ (1)	—
C _(INN)	$C_{(INN)} = 0.0024 f(\text{TRANSDUCER}) = 0.01 \text{ } \mu\text{F}$ (2)	—
C _T	100 pF	If 5 cm is the minimum requirement, then no hardware-transducer tuning is required (no damping resistor or tuning capacitor in parallel to transducer)
D1	RF071M2S	Schottky diode recommended
D2	TVS3300	Transient suppression
XDCR	MA58MF14-7N	—
XFMR	—	—
C _(XFMR)	22 μF	C _(XFMR) is intended to act as a fast-discharge capacitor during the bursting stage of a burst+listen command
C _(XFMR)	100 nF	Decoupling capacitor to mitigate ripple at the VPWR pin

The PGA460-Q1 device is an intended emitter at the center frequency of the transducer. The only risk to compromising the PGA460-Q1 performance is if another source or noise is switching within ±10 kHz of this frequency due to the BPF bandwidth of the device.

The LM5166 has a switching frequency as high as 600 kHz. The selected switching frequency for the converter is 550 kHz. The COT control is preferred over the PFM mode for obtaining a nearly-constant operating frequency. Better frequency control is important to avoid compromising performance. The following Figure 9 shows the recommended component values for the LM5166 in order to have 8 V at the output, which powers the PGA460 device and the center-tap of the transformer. The designer can control the peak-to-peak voltage at the secondary side of the transformer, which connects to the transducer, by adjusting the preset driver current limit of the PGA460 device (between 50 m to 500 mA). Adjusting the driver current limit effectively changes the equivalent turns ratio of the transformer, which prevents overly high voltages from overdriving the transducer.

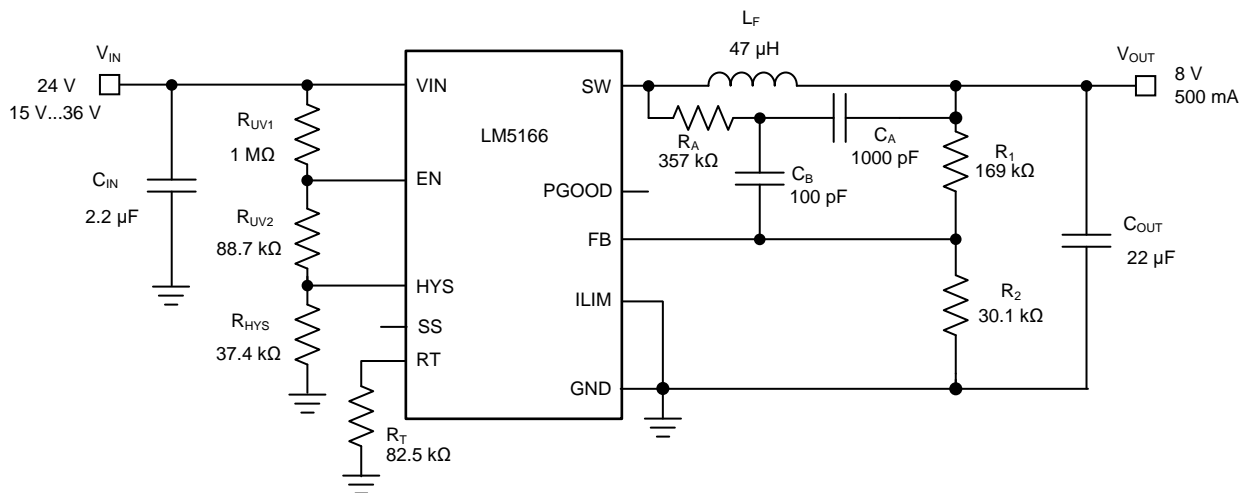

Copyright © 2017, Texas Instruments Incorporated

Figure 9. LM5166 Recommended Component Values

2.4 System Design Theory

2.4.1 Physical Principals of Ultrasound

Ultrasound is defined as a sound at frequencies greater than 20 kHz. Ultrasonic measurements are based on the travel time and speed estimation of sound waves that are transmitted above the human-detectable frequency range (20 kHz). Sound waves are longitudinal pressure waves in the medium in which they are traveling (that is, the particles in the medium vibrate in a direction parallel to the movement of the wave). Consider sound as vibrations in a medium. Sound requires a medium to propagate. Sound does not exist in places within an absolute vacuum such as in outer space. Sound waves can travel through all states of matter—solid, liquid, and gas. Sound travels faster in solids than in liquids and faster in liquids than in gases.

Ultrasonic devices are used in many applications either to detect objects or to measure distances.

2.4.2 Time of Flight (ToF)

Ultrasonic applications are based upon the reflection of sound waves. Objects whose dimensions are larger than the wavelength of the impinging sound waves reflect them; these reflected waves are known as an echo. The measurement principle of this application is as follows: If the speed of sound in the medium is known and the time taken for the sound waves to travel the distance from the source to the object and back is measured, the distance from the source to the object can be computed accurately. Here, the medium for the sound waves is air and the sound waves used are ultrasonic. The ultrasonic waves are sounds of frequencies above 20 kHz, which humans are unable to hear. Sound waves travel twice the distance (D) between the source and the object, so the total distance traveled by sound waves is computed by the formula given in [Equation 3](#). The speed of sound in air is C_{AIR} and the measured round-trip ToF for the sound waves to travel from the source to the object and back is T seconds.

$$\text{Total Distance} = 2 \times D = C_{AIR} \times T \quad (3)$$

$$\text{Actual Distance (D)} = C_{AIR} \times T = 13627 . 2 \times T \text{ inches} \quad (4)$$

Figure 10 shows a diagram of the ToF measurement principle.

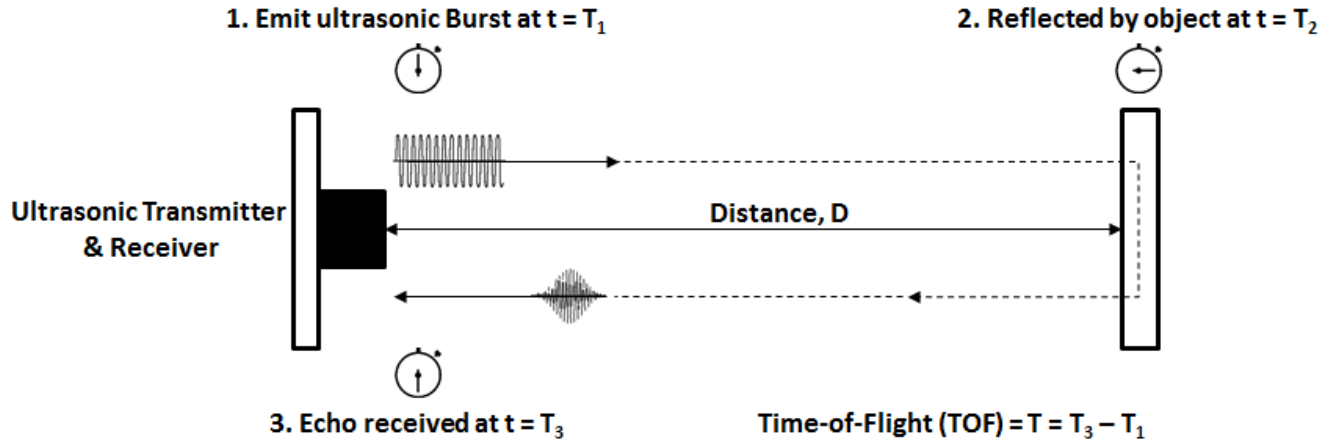

Figure 10. ToF Measurement

For a contactless ultrasonic distance measurement, the system must rely on the object to reflect the pulse back to the system as an echo. The amplitude of the echo depends on the reflecting material and surface, distance, size, and orientation of the object.

2.4.3 Physical Parameters

2.4.3.1 Material and Surface

The nature of surface affects the amount of sound energy reflected or absorbed. Ultrasonic sensors are capable of detecting most objects and materials with varying surface types, such as:

- Metal or non-metal
- Clear or opaque
- Granular (with sufficient acoustic reflectivity)
- Wet or dry
- Rough or smooth

A disadvantage of the ultrasonic sensor is that sound-absorbing objects such as cloths, cotton, wool, carpets, soft rubber, and foam reflect poorly. Therefore, the maximum measurable range is lower for such objects. Detecting objects with a large surface undulation can be difficult because of irregular reflection.

2.4.3.2 Distance

The strength of ultrasonic waves propagated into the air attenuates rapidly with distance (inverse square). This decrease originates from a diffusion loss on a spherical surface due to the diffraction phenomenon and absorption loss, where the medium absorbs energy. As Figure 11 shows, the higher the frequency of the ultrasonic wave, the bigger the attenuation rate and the shorter the distance the wave reaches. Therefore, the shorter the distance of an object from a sensor, the stronger the returning echo. As the ultrasonic frequency increases, so does the attenuation of the sound waves in the air; therefore, long-range sensors work at low frequencies, and short-range sensors work at high frequencies.

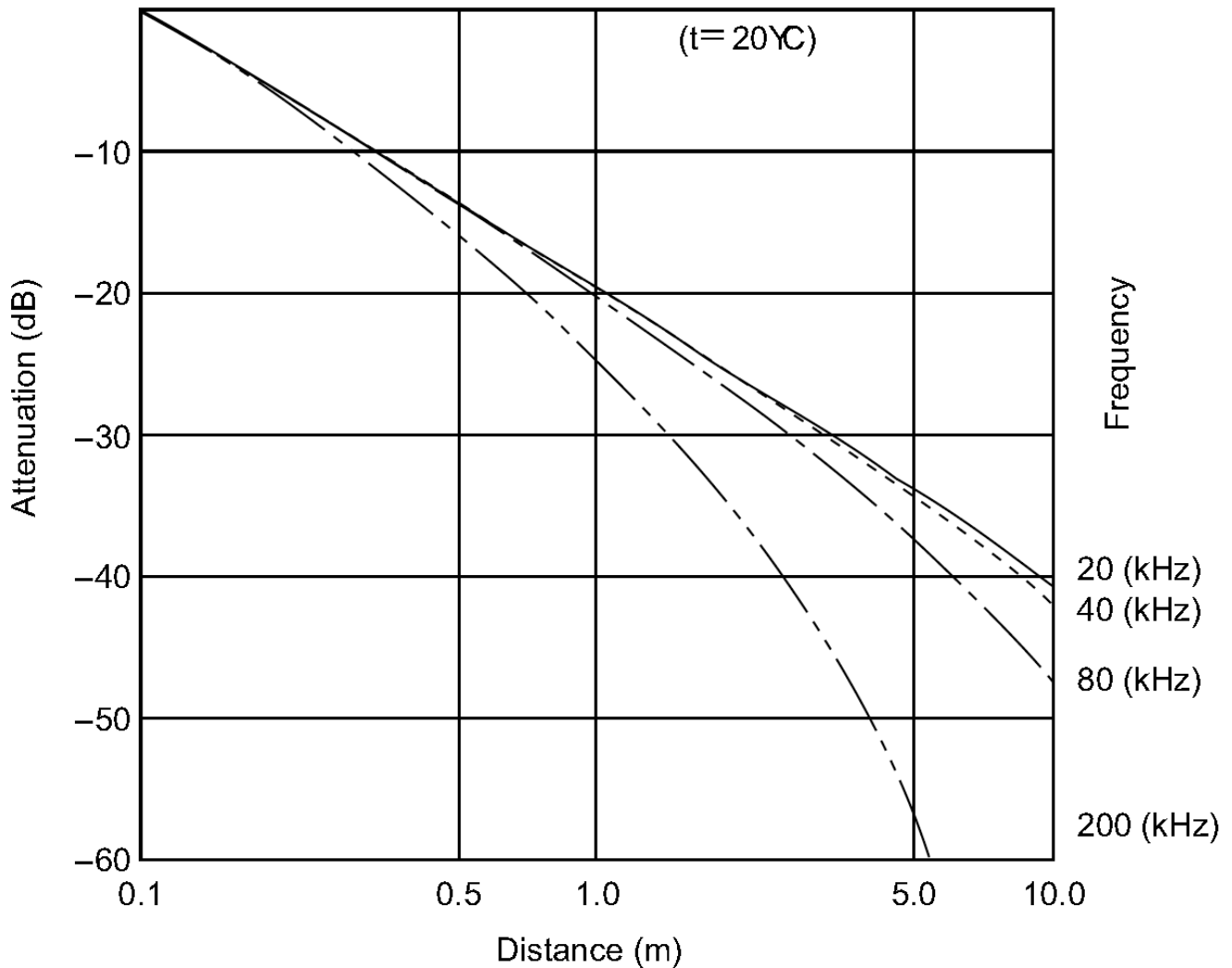

Figure 11. Attenuation of Ultrasonic Waves With Distance

2.4.3.3 Size

Reflections of ultrasound depend upon the size of the objects with respect to the wavelength of the transmitted ultrasound. Objects with dimensions larger than the wavelength of the impinging sound waves reflect them; therefore, bigger objects reflect more signal than smaller objects. The signal strength of the returned echo drops off as the object size decreases.

2.4.3.4 Orientation

The amplitude of the reflected signal not only depends on the reflection coefficient of an object, but also on its orientation. Most of the sound energy reflects back to the transducer, resulting in a high-amplitude echo when the surface is perpendicular to the ultrasound beam. However, if the user tilts the surface of this object 45°, almost all the energy reflects away from the surface, which results in a very-low-amplitude return echo to the transducer (see [Figure 12](#)).

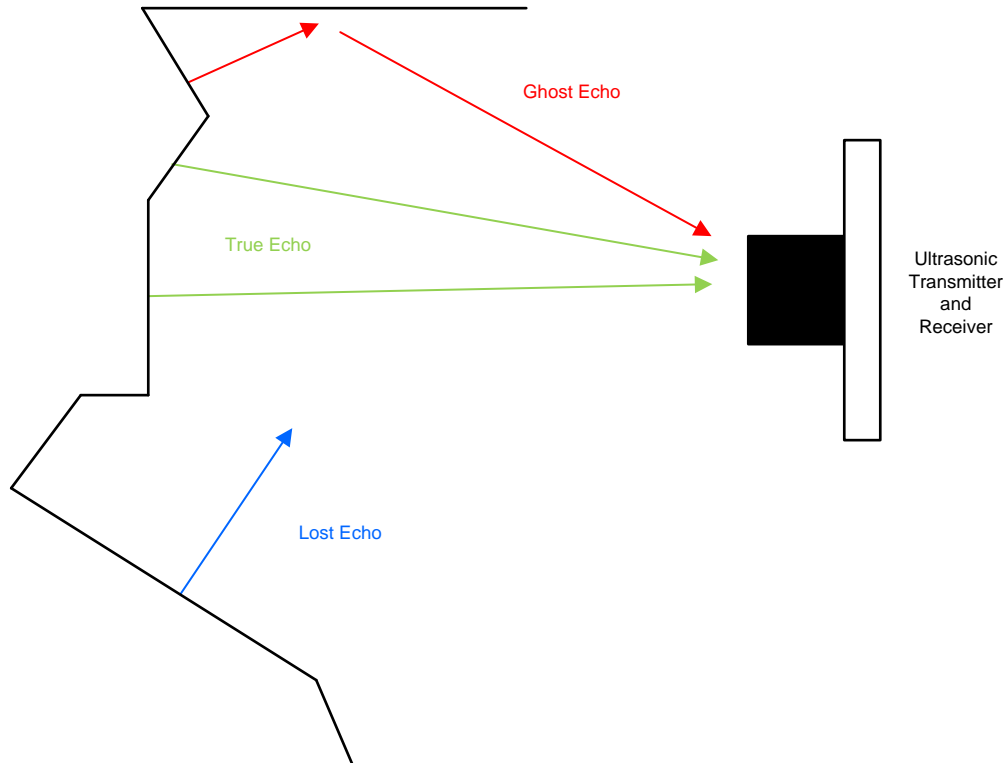

Figure 12. Echoes From Surfaces at Different Orientations

The speed of sound depends on various environmental factors like air temperature, relative humidity, pressure, density, air composition, altitude, wind speed, and direction of sound. If air turbulence is present along the path from the sensor to the object, then the average speed of sound randomly changes, which causes the object range that the sensor computes to vary randomly from pulse to pulse. Air temperature has the most influence on the speed of sound. The speed of sound is a function of air temperature that the designer can approximately determine using [Equation 5](#):

$$C_{AIR}(T) = 331.3 + 0.6 T \text{ m/s} \tag{5}$$

where,

- $C_{AIR}(T)$ = Speed of sound in dry air as a function of temperature in m/s,
- T = Temperature of air in °C.

Calculate the approximate speed of sound in dry air at temperatures near 0°C using [Equation 6](#).

$$C_{AIR}(T) = (331.3 + 0.606 \times T) \text{ m/s} \tag{6}$$

Figure 13 shows that warmer temperatures increase the speed of sound because warmer particles generally move at a faster rate. The linear approximation is nearly equal to the actual value in the range marked by the two black lines, from $T \approx 250$ K to $T \approx 350$ K.

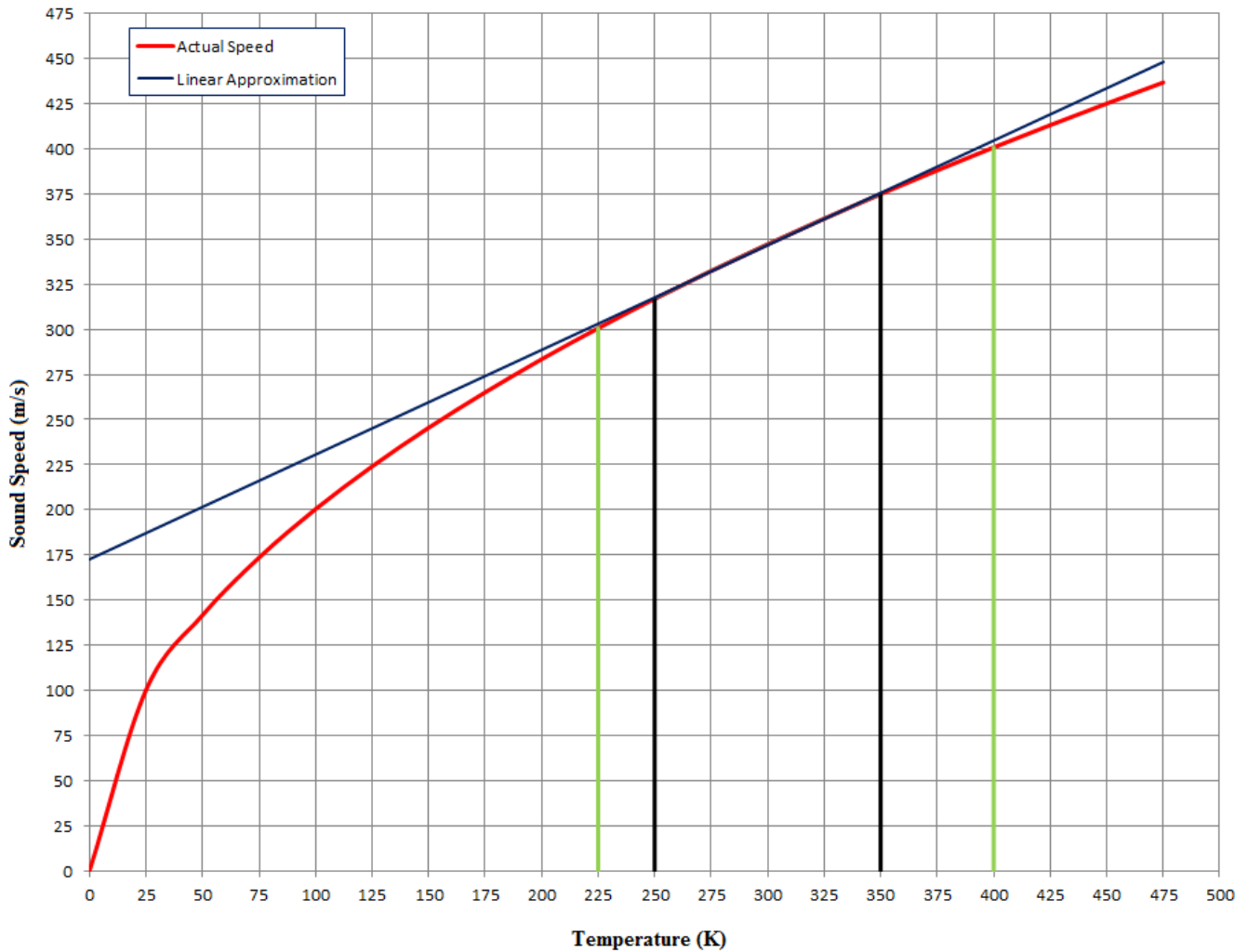

Figure 13. Speed of Sound versus Temperature

If accuracy is not a priority, stretch T from 225 K to 400 K, as the green lines show. The error is:

- $\approx 0.80\%$ at $T = 225$ K
- $\approx 0.93\%$ at $T = 400$ K

Figure 14 shows the percentage error after linear approximation in the temperature range between 150 K and 473 K.

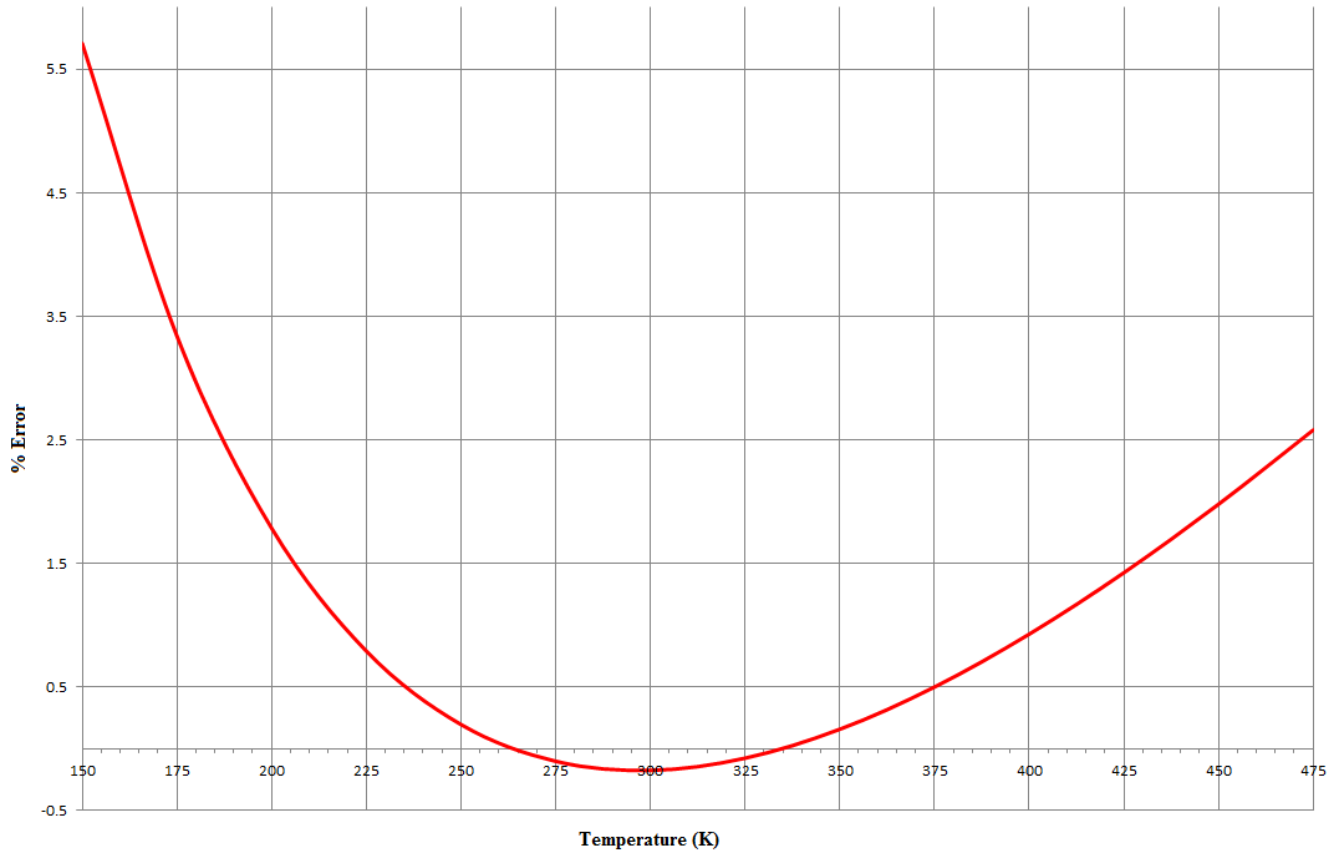

Figure 14. Percentage Error After Linear Approximation

Because the accuracy of ultrasonic technology relies on knowing the speed of sound in the medium, every unforeseen change in that speed directly affects the accuracy of the measurement. At 25°C, the speed of sound is 346.13 m/s and it changes by $\approx 0.167\%$ for each 1°C change in air temperature. As the air temperature increases, air becomes denser and sound waves travel faster. As a result, measured distances appear to shorten unless some form of temperature compensation is applied. To achieve a higher accuracy, measure air temperature with a temperature sensor that corrects for distortion, or add more compensation circuitry that measure other environmental factors (like humidity) that affect the speed of sound. However, discussing various compensation techniques are beyond the scope of this reference design.

2.4.4 Ultrasonic Transducers

An ultrasonic transducer converts AC voltage into ultrasound and ultrasound into AC voltage. In ultrasonic, the term typically refers to piezoelectric transducers. Ultrasonic transducers are distinguished from piezoelectric ceramic audio transducers because ultrasonic transducers produce sound waves above 20 kHz that are inaudible to humans. When voltage is applied to piezoelectric ceramics, mechanical distortion is generated according to the excitation voltage and its frequency. When vibration is applied to piezoelectric ceramics, an electric charge is produced. The piezoelectric ceramic has a natural resonance frequency like a bell, which means it continues to vibrate for some time when struck. If the frequency of the voltage applied to the piezoelectric ceramic is the same as its natural frequency, the crystal settles into steady large-amplitude oscillations that produce high-intensity sound waves. By applying this principle, when a 40-kHz electric signal is added to a vibrator, which has been constructed of two sheets of piezoelectric ceramics or a sheet of piezoelectric ceramics and a metal sheet, the electric signal is radiated by flexible vibration. As a reverse effect, when an ultrasonic vibration is added to the vibrator, an electric signal is produced. These effects encourage the use of piezoelectric ceramics as ultrasonic sensors.

This application uses an open-structure type ultrasonic sensor with a separate transmitter and receiver, as [Figure 15](#) shows. This multiple vibrator is a combination of a resonator and a vibrator, which is composed of a metal sheet and a piezoelectric ceramics sheet. The resonator is conical to efficiently radiate the ultrasonic waves generated by the vibration and to effectively concentrate the ultrasonic waves at the central part of the vibrator. The sensitivity of the transducer is the maximum at the resonant frequency of the piezo element. The directivity of transducer beam pattern allows detection of the object position in space. When the object enters the transducer lobe, the echo is received.

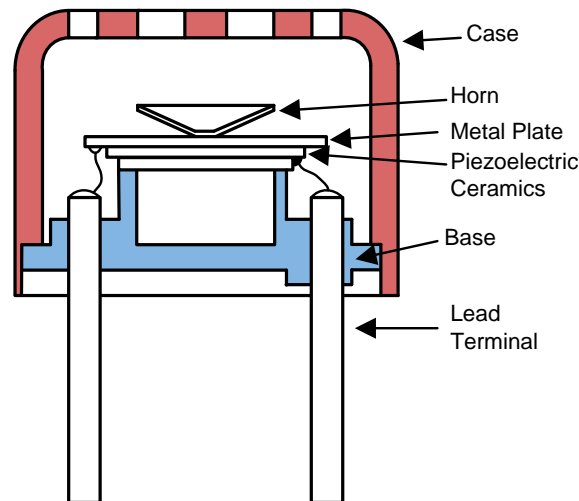

Figure 15. Ultrasonic Transducer Construction

3 Getting Started Hardware

3.1 Hardware

Head transmitters have a standardized footprint defined by the connector sizes: M5, M8, and M12. This design uses the industry standard size M12 connector (J1) and enables the printed-circuit board (PCB) width of 8.9 mm to fit within a pipe of a similar diameter as the connector (see [Figure 16](#)).



Figure 16. TIDA-01386 Dimensions

The right-angle connector, J3, on the right side of the board allows the designer to connect any kind of transducer with a frequency that reaches up to 500 kHz on the board. The designer must select the transformer, T1, according to the chosen transducer to excite it properly.

If the selected transformer is too high, the designer can solder it from the bottom side of the board and direct it through the board cutout, as [Figure 17](#) shows.

In this case, a transformer with a straight-pin EP5 package is ideal. The 750317181 and 750317196, which have the same electrical characteristics as shown in [Table 5](#) and [Table 7](#), can be used for this purpose.

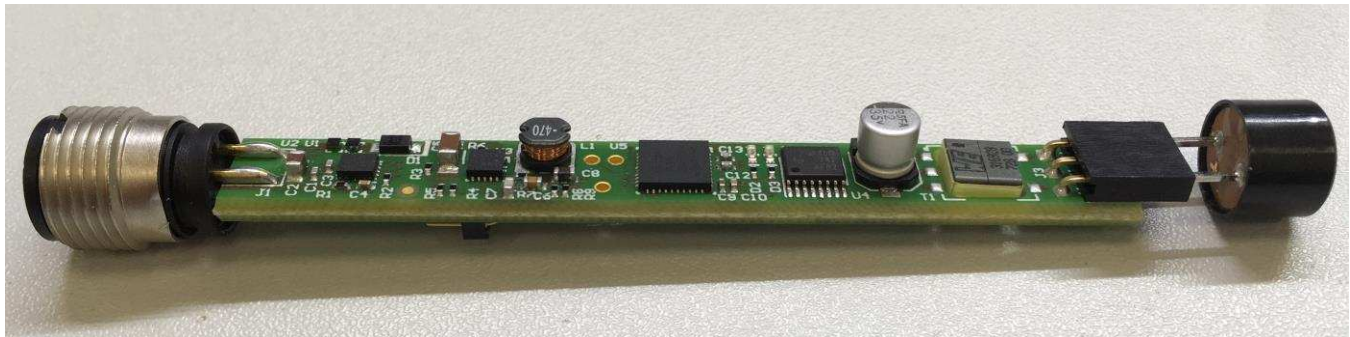

Figure 17. TIDA-01386 Board Image

The right-angle four-pin connector J2 is located on the bottom side of the board and is required to program and debug the MSP430FR5959.

4 Testing and Results

4.1 IO-Link Communication

To test the IO-Link interface, this reference design used an IO-Link master from TEConcept.

After loading the IO-Link stack from TEConcept on the MSP430FR5959 MCU, the TIDA-01386 is connected to the IO-Link master as shown in [Figure 18](#).

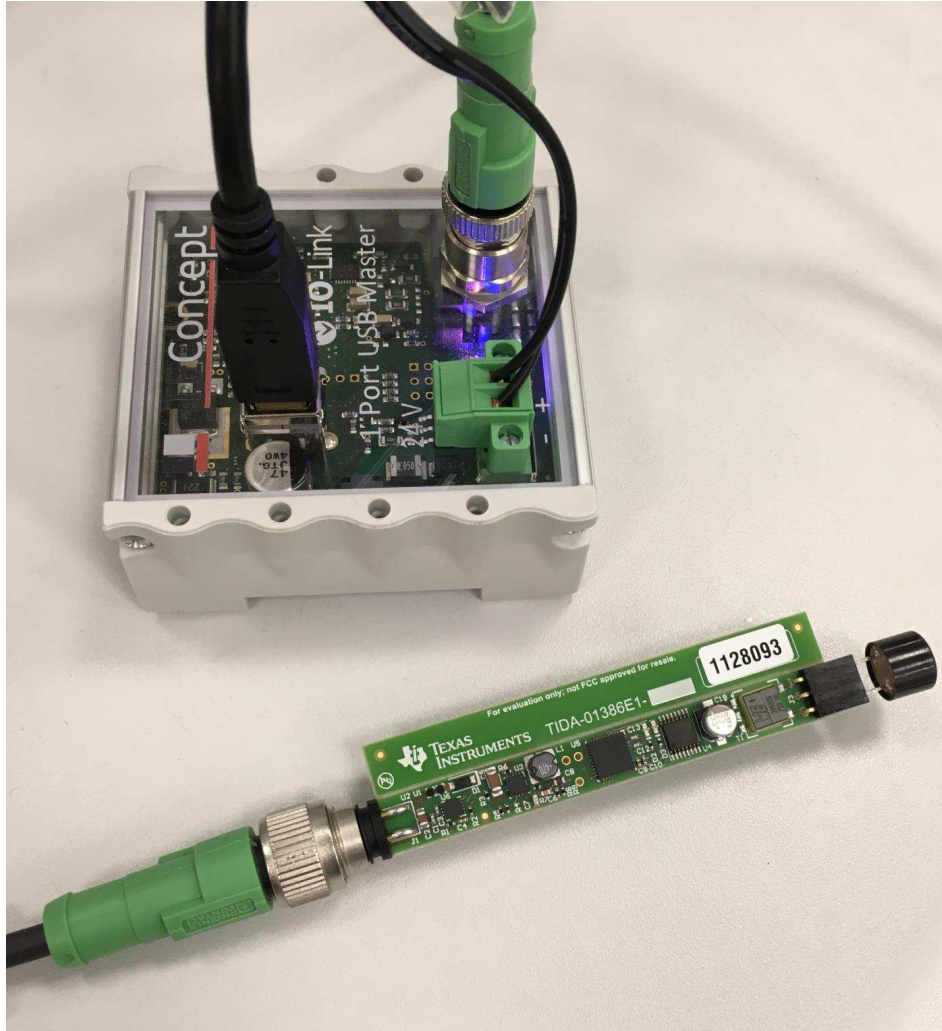

Figure 18. TIDA-01386 Connected to TEConcept Master

The following [Figure 19](#) shows that the TIOL111 transceiver has been recognized, the connection is established, and raw data are being transmitted.

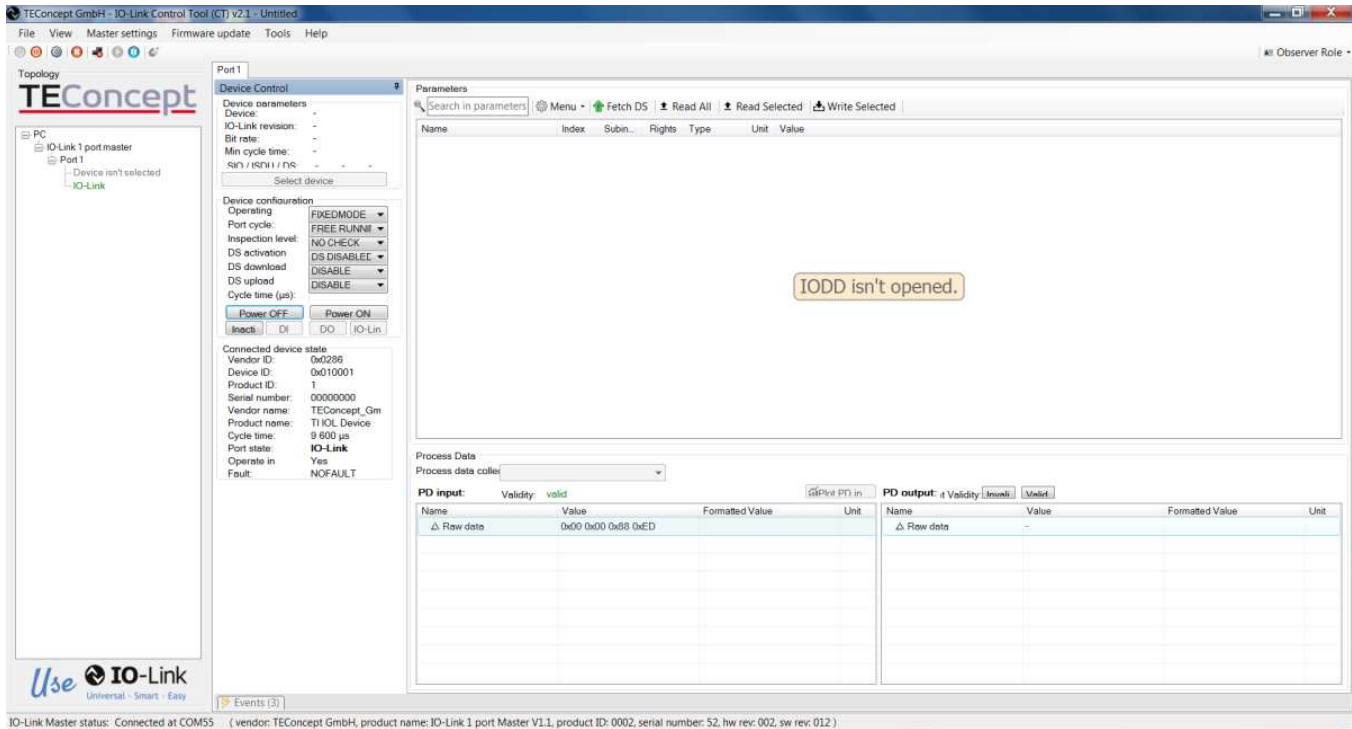

Figure 19. IO-Link Control Tool

4.2 Distance Measurements

The following results have been obtained with an MA58MF14-7N transducer plugged into the TIDA-01386. The output (OUTA, OUTB) signals of the PGA460 and the transducer-driving signal at the output of the transformer have been probed. The blue and green curves in [Figure 20](#) are the OUTA and OUTB of the PGA460 device switching at 58 kHz, as highlighted by the cursor, shifted by 180°, and with a peak voltage of 8 V, which is the power supplied to the PGA460 device. OUTA and OUTB are connected to the transformer primary coil. The rate of change for the current in the primary coil generates a voltage in the secondary coil, which is the red curve. This voltage is nothing more than the voltage supplied to the center-tap transformer, 8 V, which has been multiplied by the turns ratio of the transformer, 8.42.

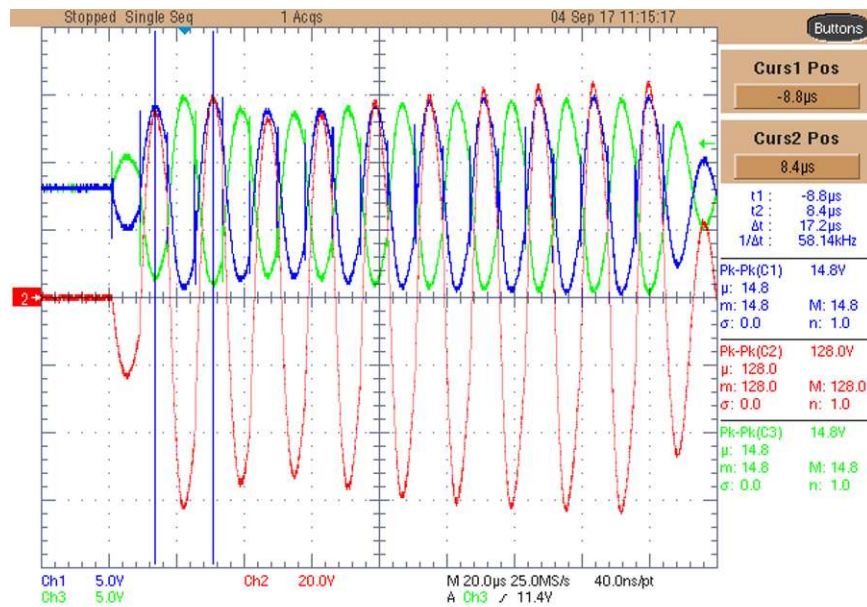

Figure 20. Driver Stage and Resulting Transducer Behavior

During one test phase, a cart was moved back and forward toward the TIDA-01386 while using the PGA460 GUI to calculate the distance from one to the other. The minimum measured distance is 30 cm while the maximum measured distance is 5 m, as Figure 21 and Figure 22 show, and with an approximate 1 cm resolution for the entire measured range. Keep in mind that, at 5 m and in an environment like an electronic lab, taking measurements is likely to be more challenging because of the many objects which reflect ultrasonic waves back to the sensor, as Figure 22 shows at around 3 m and 4 m.

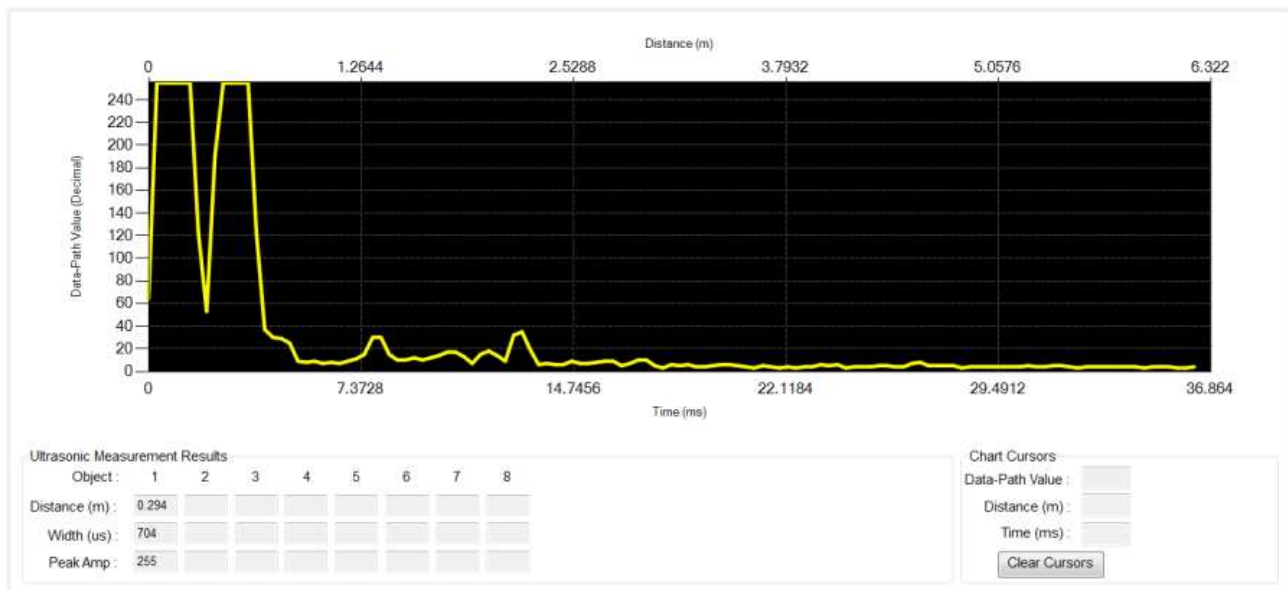

Figure 21. 30-cm Object Detection

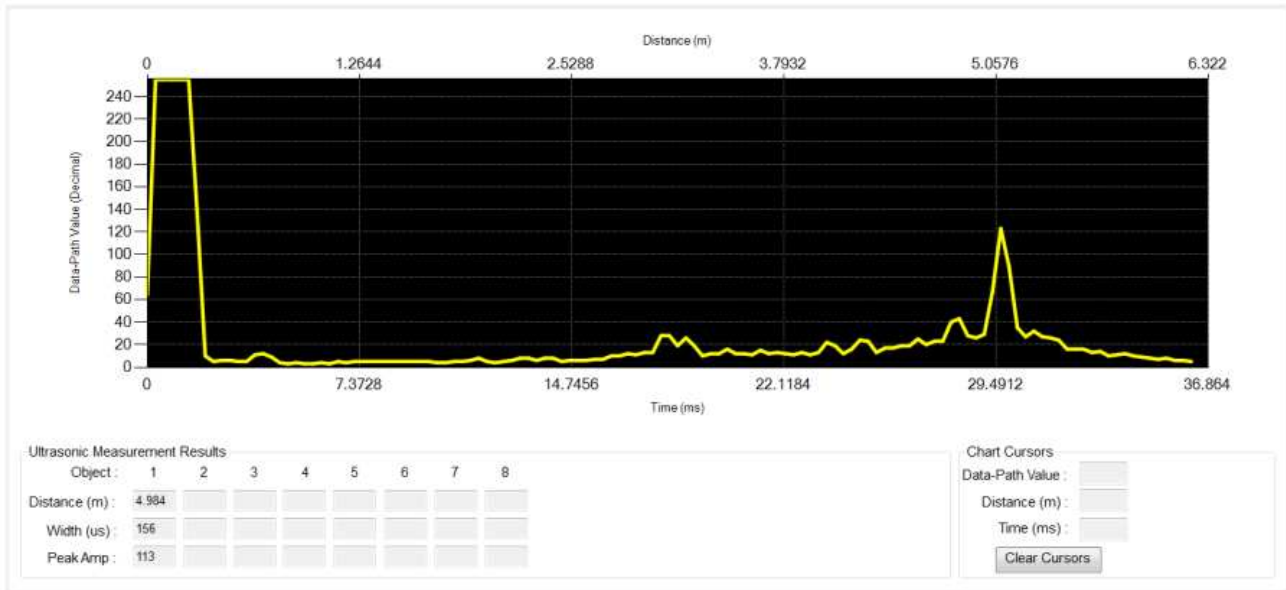

Figure 22. 5-m Object Detection

The MA300D1-1 transducer was then plugged into the TIDA-01386 and the exciting signal was monitored with a probe. Figure 23 and Figure 24 show the results of the B78416A2386A003 transformer and 750316928 transformer, respectively.

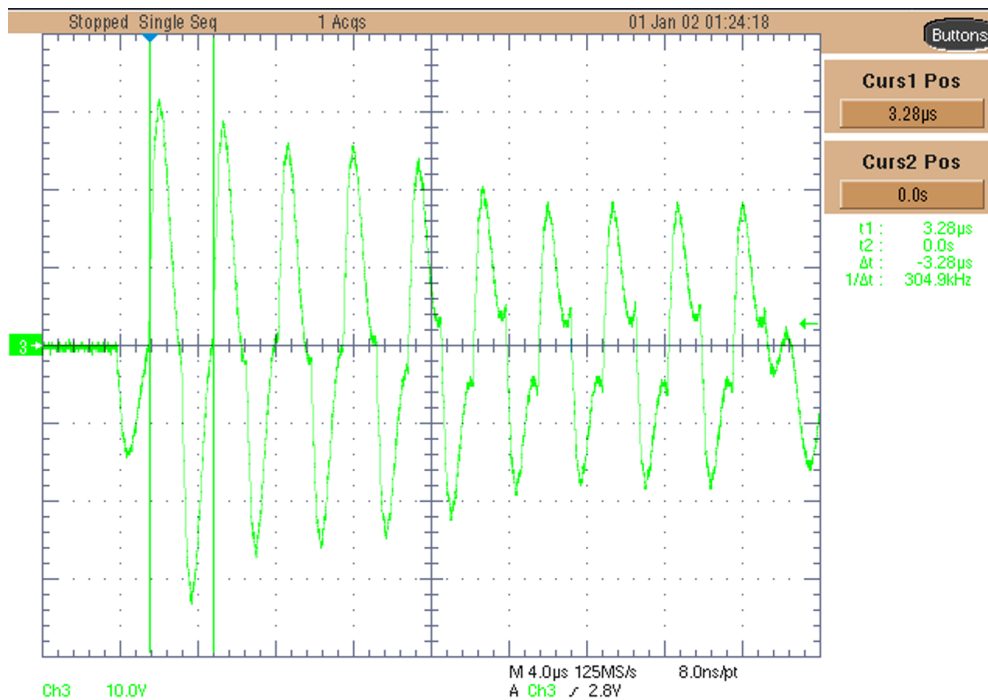

Figure 23. Exciting Signal With B78416A2386A003 Transformer

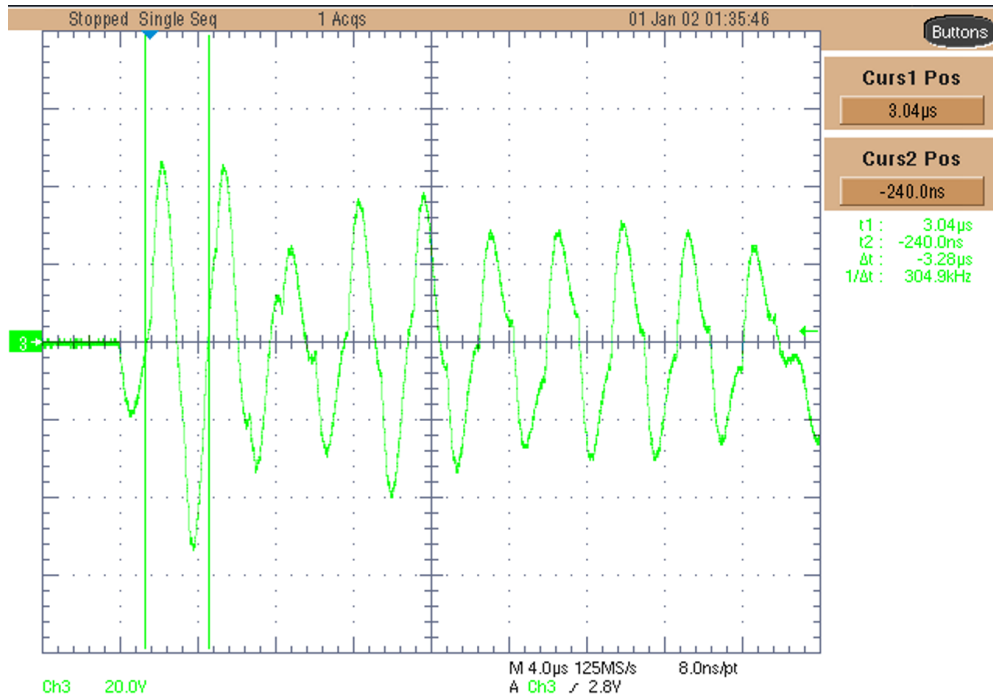

Figure 24. Exciting Signal With 750316928 Transformer

During this test phase, a plastic bottle was moved back and forward toward the TIDA-01386 while using the PGA460 GUI to calculate the distance from one to the other. The minimum measured distance is 10 cm while the maximum measured distance is 30 cm, as [Figure 25](#) and [Figure 26](#) show, and with less than a cm resolution for the entire measured range. [Figure 25](#) and [Figure 26](#) also show the repeatability of the measurements. Ten measurements were acquired for each set distance.

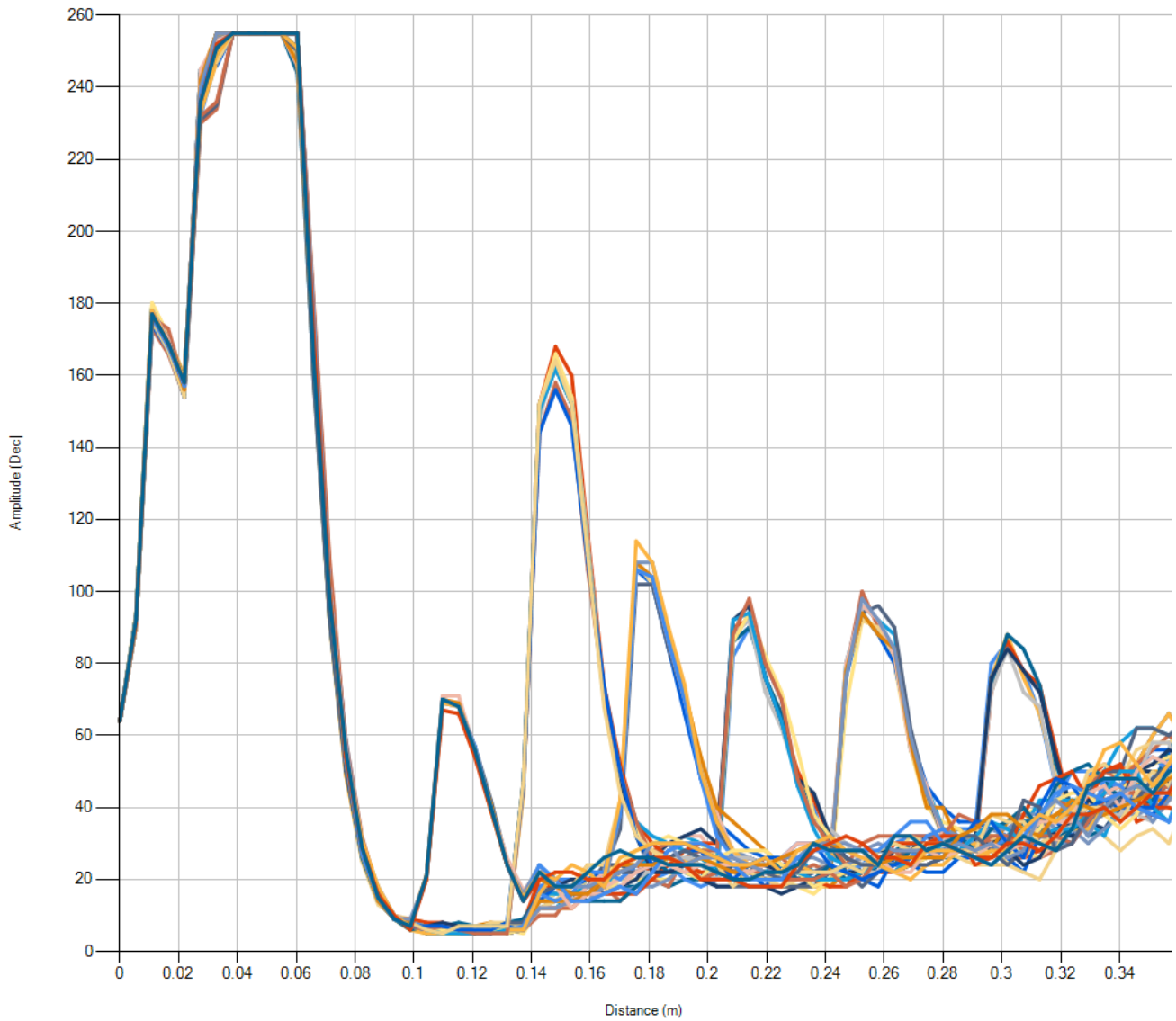

Figure 25. Repeatability Measurements With MA300D1-1 and B78416A2386A003 Transformer

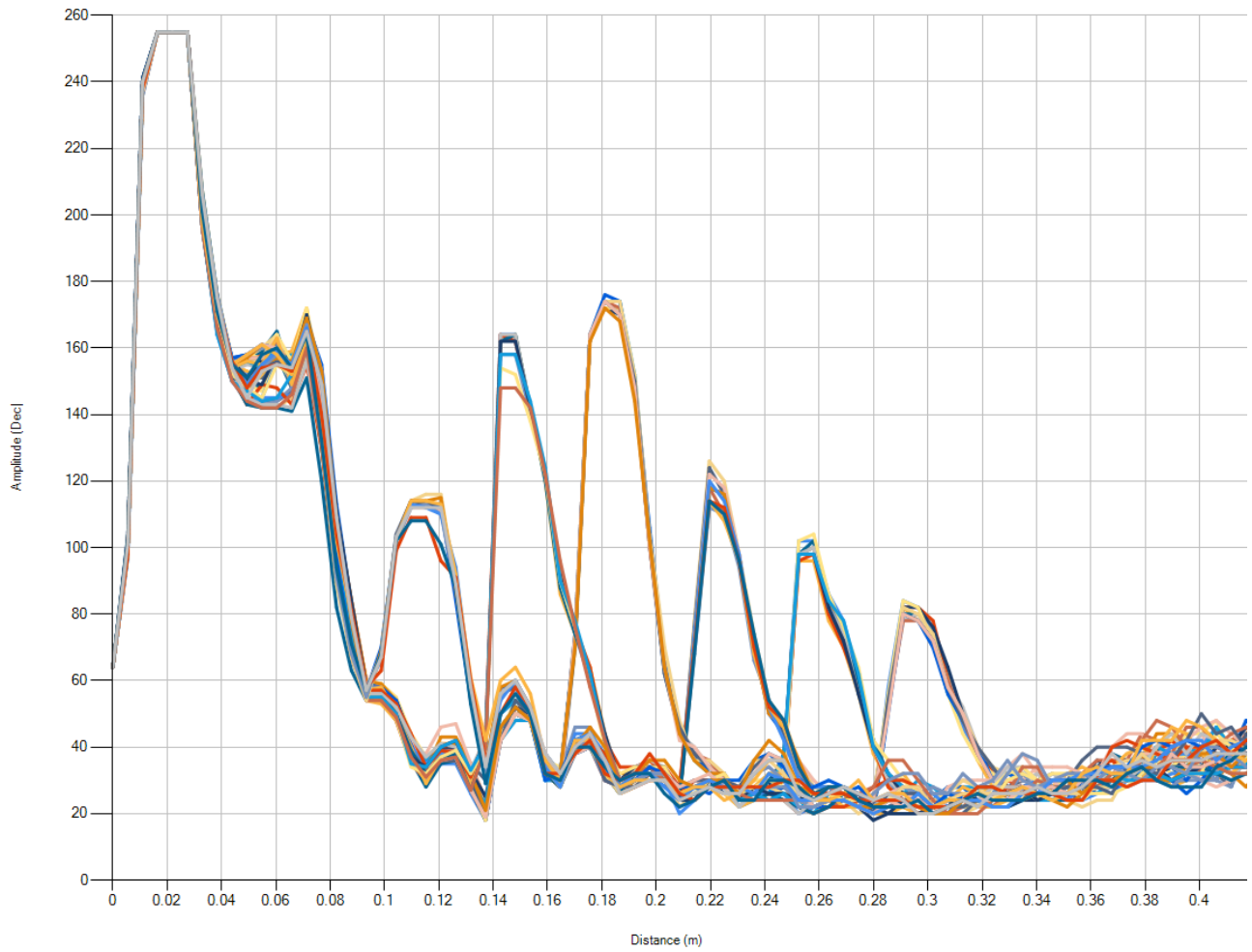

Figure 26. Repeatability Measurements With MA300D1-1 and 750316928 Transformer

5 Design Files

5.1 Schematics

To download the schematics, see the design files at [TIDA-01386](#).

5.2 Bill of Materials

To download the bill of materials (BOM), see the design files at [TIDA-01386](#).

5.3 PCB Layout Recommendations

5.3.1 Layout Prints

To download the layer plots, see the design files at [TIDA-01386](#).

5.4 Altium Project

To download the Altium project files, see the design files at [TIDA-01386](#).

5.5 Gerber Files

To download the Gerber files, see the design files at [TIDA-01386](#).

5.6 Assembly Drawings

To download the assembly drawings, see the design files at [TIDA-01386](#).

6 Software Files

To download the software files, see the design files at [TIDA-01386](#).

7 Acknowledgments

The authors wish to thank Akeem Whitehead for all his help throughout this project and on all key aspects of the PGA460.

8 About the Author

GIOVANNI CAMPANELLA is a systems engineer at Texas Instruments, where he is responsible for defining and developing reference design solutions for the industrial segment. He earned his bachelor's degree in electronic and telecommunication engineering at the University of Bologna and his master's degree in electronic engineering at the Polytechnic of Turin in Italy. He is an expert in sensors and analog signal chain.

IMPORTANT NOTICE FOR TI DESIGN INFORMATION AND RESOURCES

Texas Instruments Incorporated ("TI") technical, application or other design advice, services or information, including, but not limited to, reference designs and materials relating to evaluation modules, (collectively, "TI Resources") are intended to assist designers who are developing applications that incorporate TI products; by downloading, accessing or using any particular TI Resource in any way, you (individually or, if you are acting on behalf of a company, your company) agree to use it solely for this purpose and subject to the terms of this Notice.

TI's provision of TI Resources does not expand or otherwise alter TI's applicable published warranties or warranty disclaimers for TI products, and no additional obligations or liabilities arise from TI providing such TI Resources. TI reserves the right to make corrections, enhancements, improvements and other changes to its TI Resources.

You understand and agree that you remain responsible for using your independent analysis, evaluation and judgment in designing your applications and that you have full and exclusive responsibility to assure the safety of your applications and compliance of your applications (and of all TI products used in or for your applications) with all applicable regulations, laws and other applicable requirements. You represent that, with respect to your applications, you have all the necessary expertise to create and implement safeguards that (1) anticipate dangerous consequences of failures, (2) monitor failures and their consequences, and (3) lessen the likelihood of failures that might cause harm and take appropriate actions. You agree that prior to using or distributing any applications that include TI products, you will thoroughly test such applications and the functionality of such TI products as used in such applications. TI has not conducted any testing other than that specifically described in the published documentation for a particular TI Resource.

You are authorized to use, copy and modify any individual TI Resource only in connection with the development of applications that include the TI product(s) identified in such TI Resource. NO OTHER LICENSE, EXPRESS OR IMPLIED, BY ESTOPPEL OR OTHERWISE TO ANY OTHER TI INTELLECTUAL PROPERTY RIGHT, AND NO LICENSE TO ANY TECHNOLOGY OR INTELLECTUAL PROPERTY RIGHT OF TI OR ANY THIRD PARTY IS GRANTED HEREIN, including but not limited to any patent right, copyright, mask work right, or other intellectual property right relating to any combination, machine, or process in which TI products or services are used. Information regarding or referencing third-party products or services does not constitute a license to use such products or services, or a warranty or endorsement thereof. Use of TI Resources may require a license from a third party under the patents or other intellectual property of the third party, or a license from TI under the patents or other intellectual property of TI.

TI RESOURCES ARE PROVIDED "AS IS" AND WITH ALL FAULTS. TI DISCLAIMS ALL OTHER WARRANTIES OR REPRESENTATIONS, EXPRESS OR IMPLIED, REGARDING TI RESOURCES OR USE THEREOF, INCLUDING BUT NOT LIMITED TO ACCURACY OR COMPLETENESS, TITLE, ANY EPIDEMIC FAILURE WARRANTY AND ANY IMPLIED WARRANTIES OF MERCHANTABILITY, FITNESS FOR A PARTICULAR PURPOSE, AND NON-INFRINGEMENT OF ANY THIRD PARTY INTELLECTUAL PROPERTY RIGHTS.

TI SHALL NOT BE LIABLE FOR AND SHALL NOT DEFEND OR INDEMNIFY YOU AGAINST ANY CLAIM, INCLUDING BUT NOT LIMITED TO ANY INFRINGEMENT CLAIM THAT RELATES TO OR IS BASED ON ANY COMBINATION OF PRODUCTS EVEN IF DESCRIBED IN TI RESOURCES OR OTHERWISE. IN NO EVENT SHALL TI BE LIABLE FOR ANY ACTUAL, DIRECT, SPECIAL, COLLATERAL, INDIRECT, PUNITIVE, INCIDENTAL, CONSEQUENTIAL OR EXEMPLARY DAMAGES IN CONNECTION WITH OR ARISING OUT OF TI RESOURCES OR USE THEREOF, AND REGARDLESS OF WHETHER TI HAS BEEN ADVISED OF THE POSSIBILITY OF SUCH DAMAGES.

You agree to fully indemnify TI and its representatives against any damages, costs, losses, and/or liabilities arising out of your non-compliance with the terms and provisions of this Notice.

This Notice applies to TI Resources. Additional terms apply to the use and purchase of certain types of materials, TI products and services. These include; without limitation, TI's standard terms for semiconductor products (<http://www.ti.com/sc/docs/stdterms.htm>), [evaluation modules](#), and [samples](http://www.ti.com/sc/docs/sampterm.htm) (<http://www.ti.com/sc/docs/sampterm.htm>).

Mailing Address: Texas Instruments, Post Office Box 655303, Dallas, Texas 75265
Copyright © 2017, Texas Instruments Incorporated