

## Maximum Input 36V / 2A / Fixed Output 12V

### DESCRIPTION

The FDSM series of the Magl<sup>3</sup>C power module family is a fixed output voltage, fully integrated DC-DC power supply including the controller IC, inductor and capacitors all in one package.

For optimal performance the module is recommended for use with an external input capacitor and output capacitor, reducing design effort and complexity to a minimum.

The FDSM ensures fast time to market and low development costs.

It is pin compatible with the common 78xx linear regulator series. The high efficiency reduces the power dissipation and in many cases a heatsink and assembly parts are unnecessary.

24V to 12V conversion achieves up to 96% efficiency.

The standard THT (11.5 x 9 x 17.5mm) package allows for easy assembly.

### TYPICAL APPLICATIONS

- Point-of-Load DC-DC applications
- Replacement for linear regulators
- Interface and microcontroller supplies
- General purpose

### TYPICAL CIRCUIT DIAGRAM

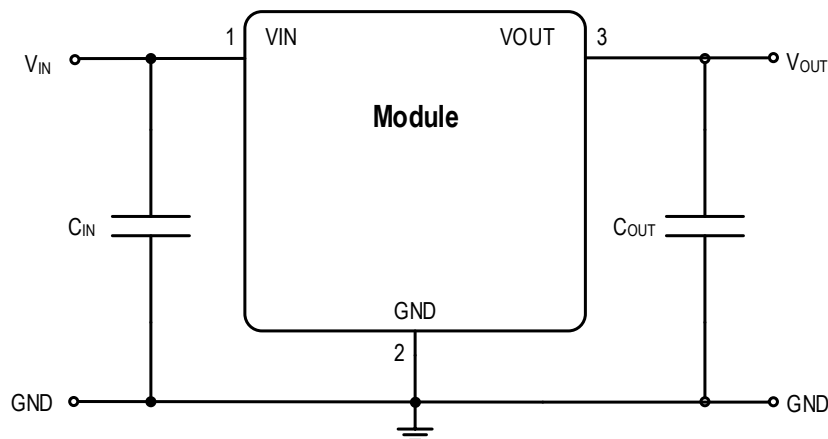

### FEATURES

- Peak efficiency up to 96%
- Current capability up to 2A
- Input voltage range up to 36V
- No minimum load required
- Partially integrated input and output capacitors
- Integrated inductor
- Low output voltage ripple (<60mV<sub>pp</sub>)
- Current mode control
- PFM/PWM mode
- Internal soft-start
- Thermal shutdown
- Short circuit protection
- Cycle by cycle current limit
- Pin compatible with the FDSM power modules series
- Ambient temperature range: -40°C to 85°C
- RoHS & REACH compliant
- Complies with EN55032 (CISPR-32) class B conducted and radiated emissions standard

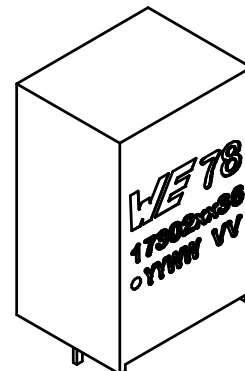

## CONTENTS

<b>1</b>	<b>PINOUT</b>	<b>4</b>
<b>2</b>	<b>ORDERING INFORMATION</b>	<b>5</b>
<b>3</b>	<b>PIN COMPATIBLE FAMILY MEMBERS</b>	<b>5</b>
<b>4</b>	<b>SALES INFORMATION</b>	<b>5</b>
<b>5</b>	<b>ABSOLUTE MAXIMUM RATINGS</b>	<b>6</b>
<b>6</b>	<b>OPERATING CONDITIONS</b>	<b>6</b>
<b>7</b>	<b>ELECTRICAL SPECIFICATIONS</b>	<b>7</b>
<b>8</b>	<b>RoHS, REACH</b>	<b>8</b>
<b>9</b>	<b>RELIABILITY</b>	<b>8</b>
<b>10</b>	<b>PACKAGE SPECIFICATIONS</b>	<b>8</b>
<b>11</b>	<b>NOTES</b>	<b>8</b>
<b>12</b>	<b>TYPICAL PERFORMANCE CURVES</b>	<b>9</b>
12.1	Radiated and Conducted Emissions EN55032 (CISPR-32) Class B Compliance	9
12.1.1	Test Setup	9
12.1.2	Radiated and Conducted Emissions	10
12.2	DC Performance Curves	11
12.2.1	Efficiency	11
12.2.2	Thermal Derating	11
12.2.3	Load Regulation	12
12.2.4	Line Regulation	12
<b>13</b>	<b>BLOCK DIAGRAM</b>	<b>13</b>
<b>14</b>	<b>CIRCUIT DESCRIPTION</b>	<b>13</b>
<b>15</b>	<b>OUTPUT VOLTAGE RIPPLE</b>	<b>14</b>
<b>16</b>	<b>PROTECTION FEATURES</b>	<b>15</b>
16.1	Soft-Start	15
16.2	Over Temperature Protection (OTP)	16
16.3	Short Circuit Protection (SCP)	16
16.4	Over Current Protection (OCP)	17
<b>17</b>	<b>DESIGN EXAMPLE</b>	<b>18</b>
17.1	Layout	18
17.2	Schematic	19
17.3	Bill of Materials	19
<b>18</b>	<b>GENERATING NEGATIVE OUTPUT VOLTAGES</b>	<b>20</b>
<b>19</b>	<b>GENERATING COMPLEMENTARY OUTPUT VOLTAGES</b>	<b>21</b>



---

<b>20 HANDLING RECOMMENDATIONS</b> . . . . .	<b>22</b>
20.1 Solder Profile . . . . .	22
<b>21 PHYSICAL DIMENSIONS</b> . . . . .	<b>23</b>
21.1 Component . . . . .	23
21.2 Recommended Drill Holes . . . . .	24
21.3 Tube . . . . .	24
<b>22 DOCUMENT HISTORY</b> . . . . .	<b>25</b>
<b>23 LIST OF FIGURES</b> . . . . .	<b>26</b>
<b>24 LIST OF TABLES</b> . . . . .	<b>27</b>
<b>25 CAUTIONS AND WARNINGS</b> . . . . .	<b>28</b>
<b>26 IMPORTANT NOTES</b> . . . . .	<b>29</b>

## 1 PINOUT (PACKAGE TYPE B)

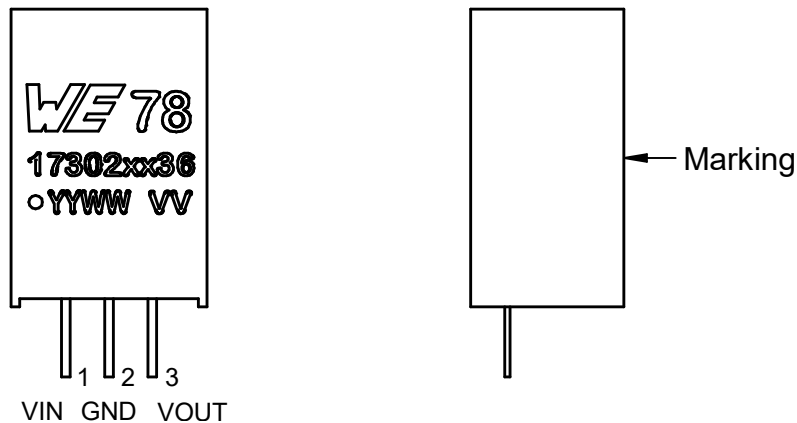

Figure 1: Pinout type B package (pins are located at the back).

Table 1: Marking description.

MARKING	DESCRIPTION
WE	Würth Elektronik eiSos GmbH & Co. KG
78	Indicates compatibility with 78xx linear regulator
173021236	Order code
YY	Year
WW	Calendar week
VV	Output voltage

Table 2: Pin description.

SYMBOL	NUMBER	TYPE	DESCRIPTION
VIN	1	Power	The supply input pin is a terminal for an input voltage source. It is recommended to use 2x10 $\mu$ F/50V input capacitors.
GND	2	Power	Ground pin; reference for $V_{IN}$ and $V_{OUT}$ .
VOUT	3	Power	Regulated output voltage pin. It is recommended to use a 22 $\mu$ F/25V output capacitor.

## 2 ORDERING INFORMATION

ORDER CODE	SPECIFICATIONS	PACKAGE	PACKAGING UNIT
173021236	36V / 2A / 12Vout version	SIP-3 Type B	Tube with 44 pieces

## 3 PIN COMPATIBLE FAMILY MEMBERS

ORDER CODE	SPECIFICATIONS	PACKAGE	PACKAGING UNIT		
173950378	28V / 0.5A / 3.3Vout	SIP-3 Type F	Tube with 42 pieces		
173950578	28V / 0.5A / 5Vout				
173010378	28V / 1A / 3.3Vout				
173010578	28V / 1A / 5Vout				
173010342	42V / 1A / 3.3Vout				
173010542	42V / 1A / 5Vout				
173950336	36V / 0.5A / 3.3Vout		SIP-3 Type F	Tube with 43 pieces	
173950536	36V / 0.5A / 5Vout				
173951236	36V / 0.5A / 12Vout				
173951536	36V / 0.5A / 15Vout				
173010335	36V / 1A / 3.3Vout				
173010535	36V / 1A / 5Vout				
173011235	36V / 1A / 12Vout				
173011535	36V / 1A / 15Vout				
173020336*	36V / 2A / 3.3Vout	SIP-3 Type B			Tube with 44 pieces
173020536*	36V / 2A / 5Vout				
173950375	74.5V / 0.5A / 3.3Vout		SIP-3 Type B	Tube with 42 pieces	
173950575	74.5V / 0.5A / 5Vout				
173951275	74.5V / 0.5A / 12Vout				

\*Please note that the 2A modules have thicker pins and require the appropriate land pattern size.

## 4 SALES INFORMATION

SALES CONTACT
<p>Würth Elektronik eiSos GmbH &amp; Co. KG  EMC and Inductive Solutions  Max-Eyth-Str. 1  74638 Waldenburg  Germany  Tel. +49 (0) 7942 945 0  <a href="http://www.we-online.com/powermodules">www.we-online.com/powermodules</a>  Technical support: <a href="mailto:wpme-support@we-online.com">wpme-support@we-online.com</a></p>

## 5 ABSOLUTE MAXIMUM RATINGS

### Caution:

Exceeding the listed absolute maximum ratings may affect the device negatively and may cause permanent damage.

Table 3: Absolute maximum ratings.

SYMBOL	PARAMETER	LIMIT		UNIT
		MIN <sup>(1)</sup>	MAX <sup>(1)</sup>	
V <sub>IN</sub>	Input pin voltage	-0.3	40	V
V <sub>OUT</sub>	Output pin voltage	-0.3	16	V
T <sub>storage</sub>	Assembled, non-operating storage temperature	-40	125	°C
V <sub>esd</sub>	ESD Voltage (Human Body Model), according to EN61000-4-2 <sup>(4)</sup>	-4	4	kV

## 6 OPERATING CONDITIONS

Operating conditions are conditions under which the device is intended to be functional. All values are referenced to GND.

MIN and MAX limits are valid for the recommended ambient temperature range of -40°C to 85°C. Typical values represent statistically the utmost probable values at the following conditions: V<sub>IN</sub> = 16V to 36V, I<sub>OUT</sub> = 2A, T<sub>A</sub> = 25°C, unless otherwise noted.

Table 4: Operating conditions.

SYMBOL	PARAMETER	MIN <sup>(1)</sup>	TYP <sup>(3)</sup>	MAX <sup>(1)</sup>	UNIT
V <sub>IN</sub>	Input voltage	16	—	36	V
T <sub>a</sub>	Ambient temperature range	-40	—	85 <sup>(2)</sup>	°C
I <sub>OUT</sub>	Nominal output current <sup>(5)</sup>	—	—	2	A
C <sub>OUT MAX</sub>	Maximal output capacitance	—	—	470	µF

## 7 ELECTRICAL SPECIFICATIONS

### Caution:

MIN and MAX limits are valid for the recommended ambient temperature range of -40°C to 85°C. Typical values represent statistically the utmost probable values at the following conditions:  $V_{IN} = 24V$ ,  $I_{OUT} = 2A$ ,  $T_A = 25^\circ C$ ,  $C_{IN} = 2 \times 10\mu F$  (885012209073),  $C_{OUT} = 22\mu F$  (885012209074), unless otherwise noted.

Table 5: Electrical specifications.

SYMBOL	PARAMETER	TEST CONDITIONS	LIMIT			UNIT
			MIN <sup>(1)</sup>	TYP <sup>(3)</sup>	MAX <sup>(1)</sup>	
<b>Output Voltage</b>						
$V_{OUT}$	Regulated output voltage		—	12	—	V
	Line regulation		—	0.4	0.8	%
	Load Regulation	10% to 100% load	—	0.5	1.5	%
	Total output voltage regulation	Full load, full input voltage range	—	2	4	%
	Output voltage ripple		—	55	—	mV <sub>pp</sub>
<b>Switching Frequency</b>						
$f_{SW}$	Switching frequency	Continuous conduction mode (CCM)	—	400	—	kHz
<b>Input Current</b>						
$I_{IN}$	No load input current	Operating, switching	—	0.1	1	mA
<b>Efficiency</b>						
$\eta$	Efficiency		—	96	—	%

## 8 RoHS, REACH

Table 6: RoHS, REACH.

RoHS directive		Directive 2011/65/EU of the European Parliament and the Council of June 8th, 2011 on the restriction of the use of certain hazardous substances in electrical and electronic equipment.
REACH directive		Directive 1907/2006/EU of the European Parliament and the Council of June 1st, 2007 regarding the Registration, Evaluation, Authorization and Restriction of Chemicals (REACH).

## 9 RELIABILITY

Table 7: Reliability.

SYMBOL	PARAMETER	TEST CONDITIONS	TYP <sup>(3)</sup>	UNIT
MTBF	Mean time between failures	MIL-HDBK-217F, 25°C	2000 · 10 <sup>3</sup>	h

## 10 PACKAGE SPECIFICATIONS

Table 8: Package specifications.

ITEM	PARAMETER	TYP <sup>(3)</sup>	UNIT
Case	Black flame-retardant and heat-resistant plastic (UL94 V-0)	—	—
Potting material	Silicone (UL94V-0)	—	—
Weight		3.8	g
Vibration	5g for 20 min	MIL-STD-202, Method 204	

## 11 NOTES

- (1) Min and Max limits are 100% production tested at 25°C. Limits over the operating temperature range are guaranteed through correlation using Statistical Quality Control (SQC) methods.
- (2) Measured without heatsink. Natural convection (0 - 20LFM / 0- 0.1m/s) on a 57 x 35mm two layer test board, with 35µm (1 ounce) copper.
- (3) Typical numbers are valid at 25°C ambient temperature and represent statistically the utmost probable values assuming a Gaussian distribution.
- (4) The human body model is a 100pF capacitor discharged through a 1.5kΩ resistor into each pin. Test method is per JESD-22-114.
- (5) Depending on ambient temperature; see [THERMAL DERATING](#).



## 12 TYPICAL PERFORMANCE CURVES

If not otherwise specified, the following conditions apply:  $V_{IN} = 24V$ ;  $V_{OUT} = 12V$ ;  $I_{OUT} = 2A^{(5)}$ ;  $T_{AMB} = 25^{\circ}C$ .

### 12.1 Radiated and Conducted Emissions EN55032 (CISPR-32) Class B Compliance

The 173021236 power module is tested with a standard EMC configuration (1m wire between the module and the load) to give more realistic information about implementation in the applications. The test setup is based on CISPR-16 with the limit values taken from CISPR-32.

Measured with module on the design example shown in chapter [DESIGN EXAMPLE](#) in a Fully Anechoic Room (FAR) at 3m antenna distance.

#### 12.1.1 TEST SETUP

Input wire length:

- Radiated Emission: 160cm (80cm Horizontal + 80cm Vertical)
- Conducted Emission: 80cm

Output wire length:

- Radiated and Conducted Emissions: 100cm Horizontal

12.1.2 Radiated and Conducted Emissions

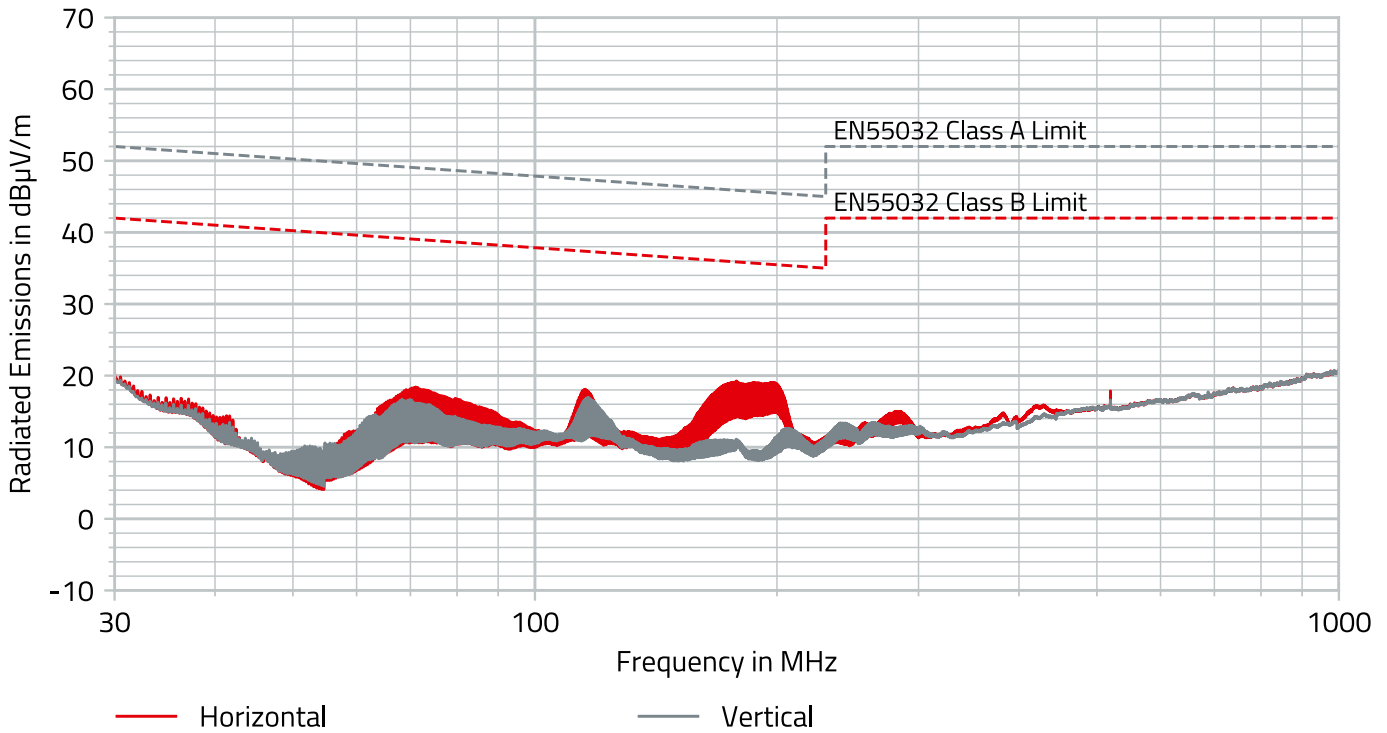

Figure 2: Radiated EMI with input filter.

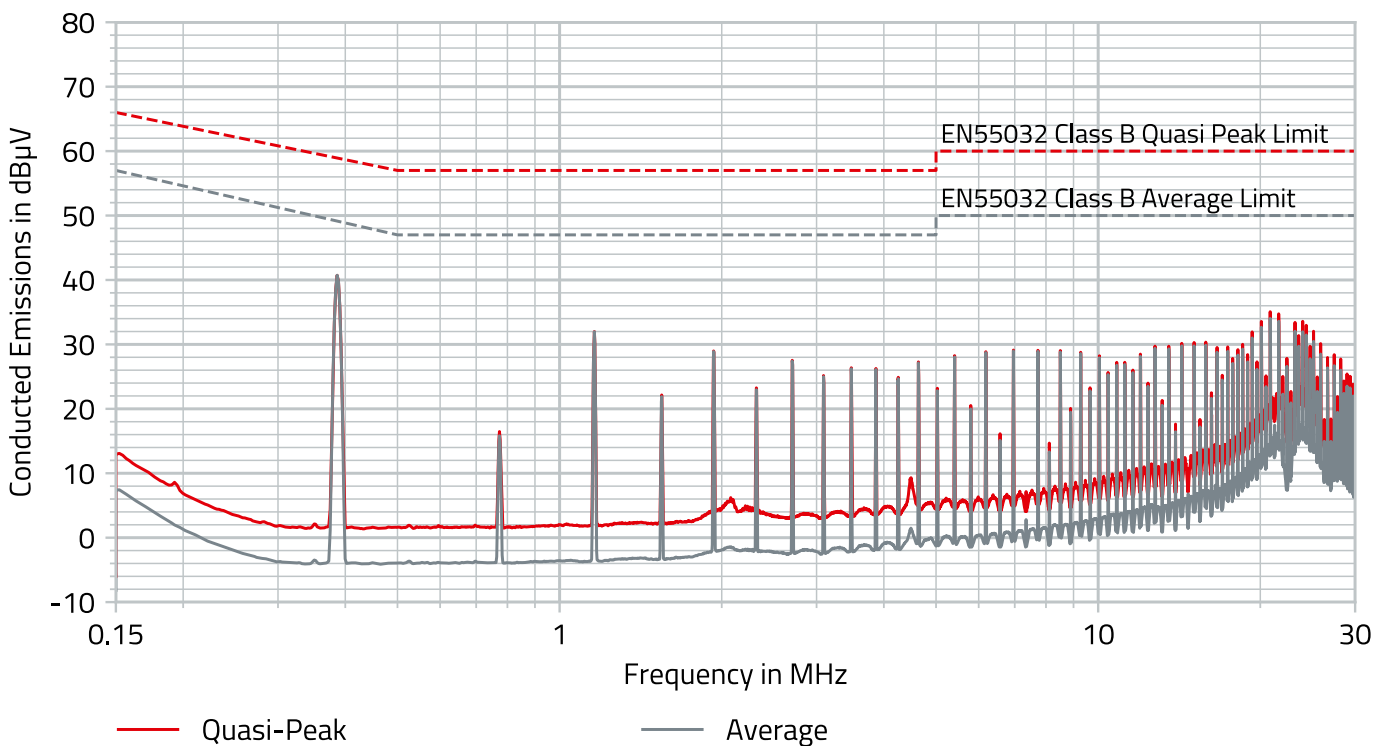

Figure 3: Conducted EMI with input filter.

## 12.2 DC PERFORMANCE CURVES

### 12.2.1 EFFICIENCY

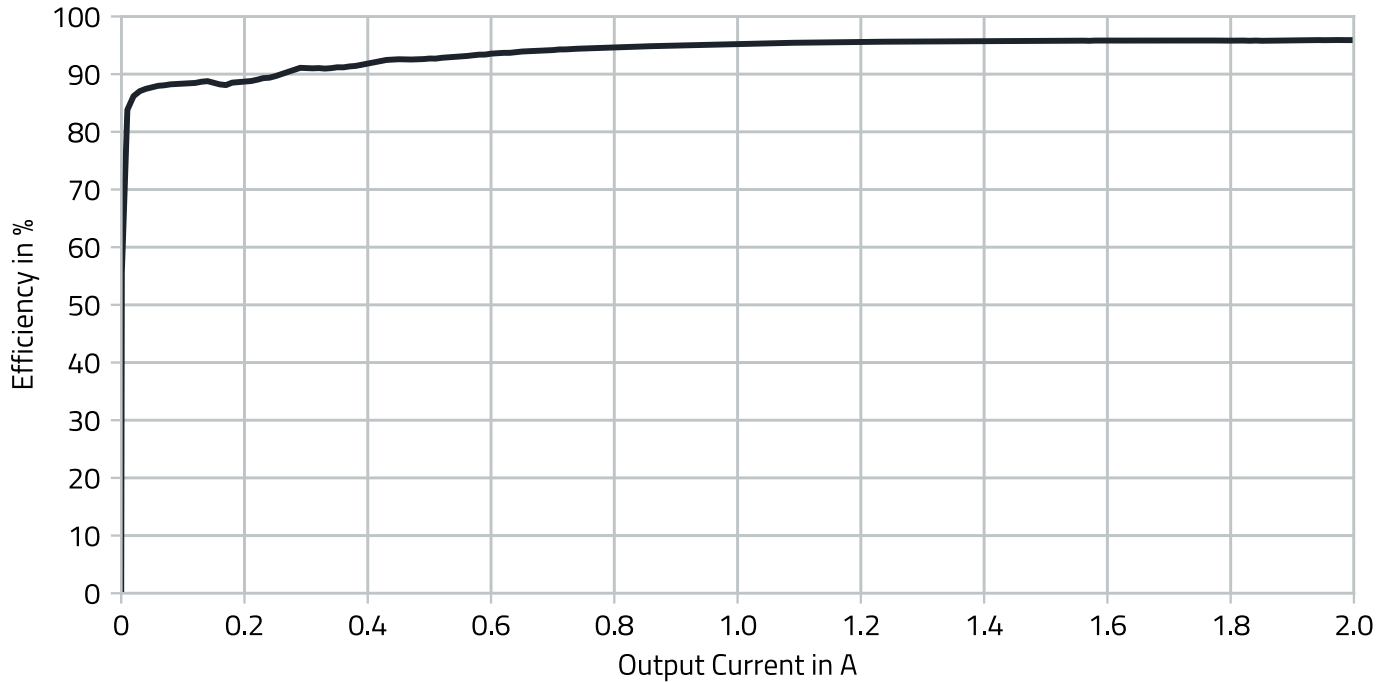

Figure 4: Efficiency.

### 12.2.2 THERMAL DERATING

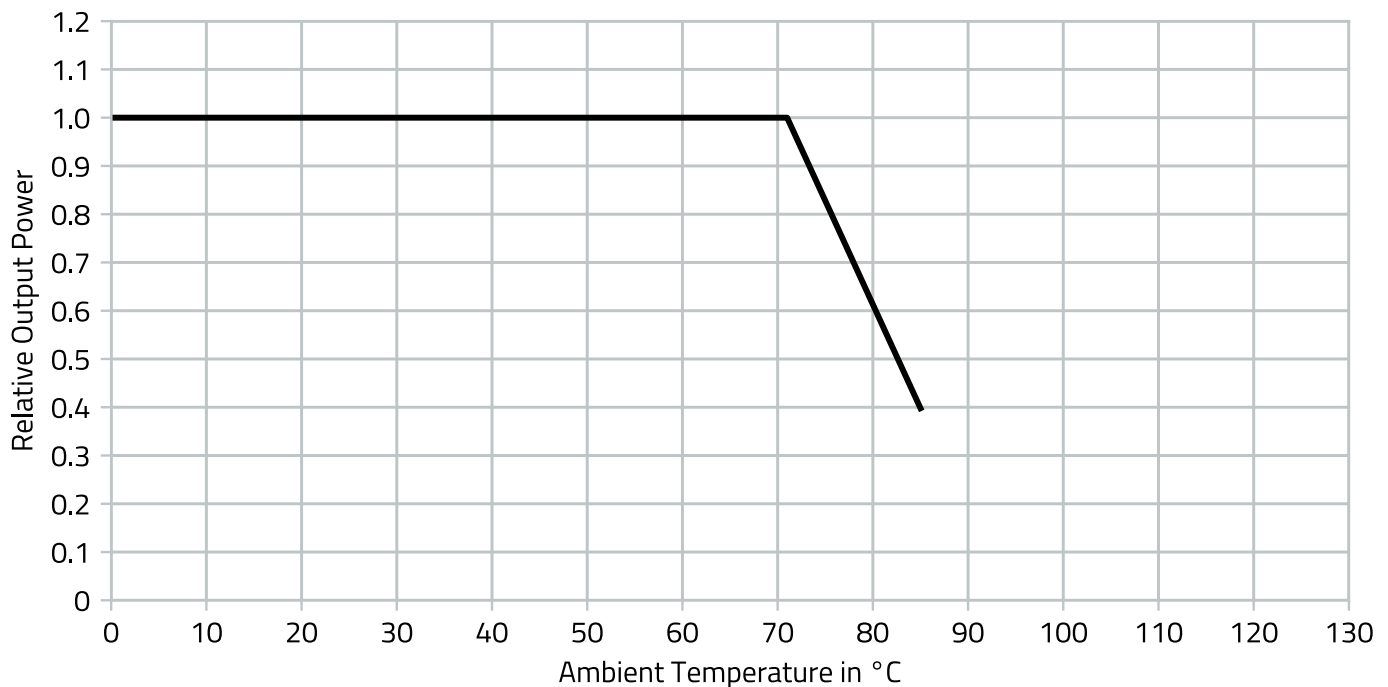

Figure 5: Thermal derating.

### 12.2.3 LOAD REGULATION

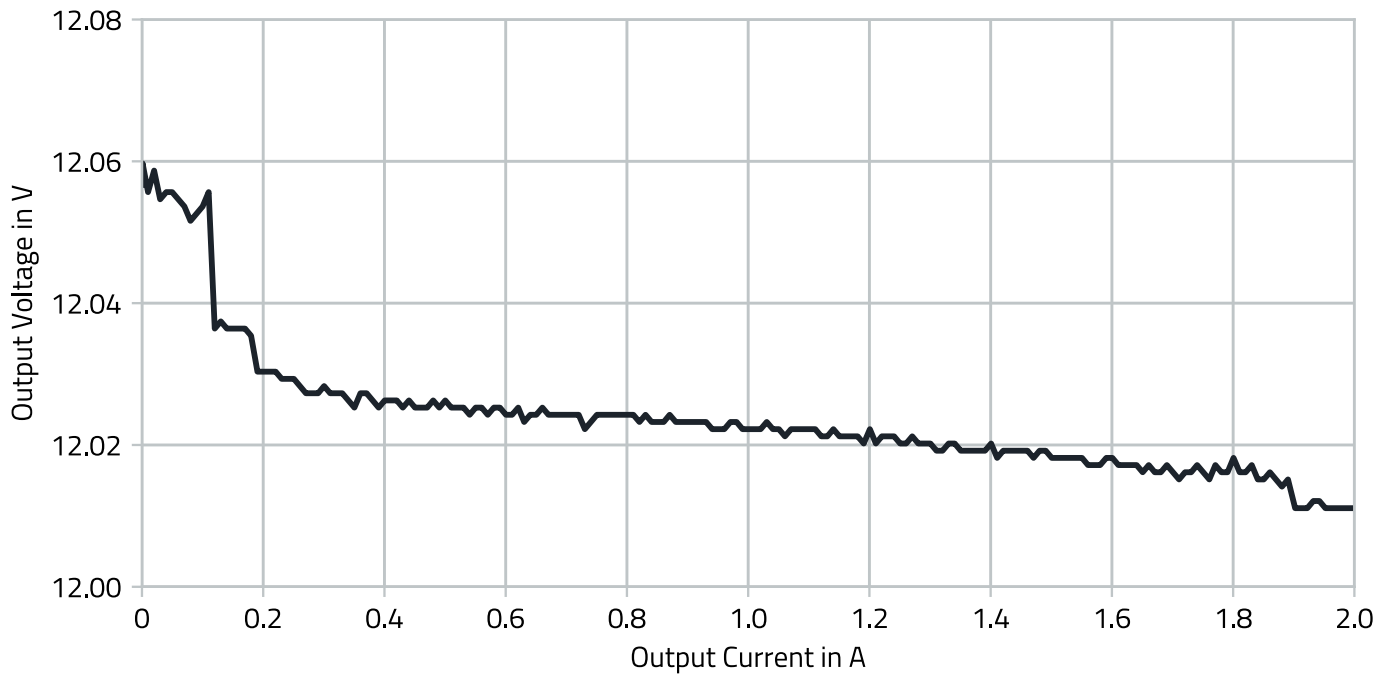

Figure 6: Load regulation.

### 12.2.4 LINE REGULATION

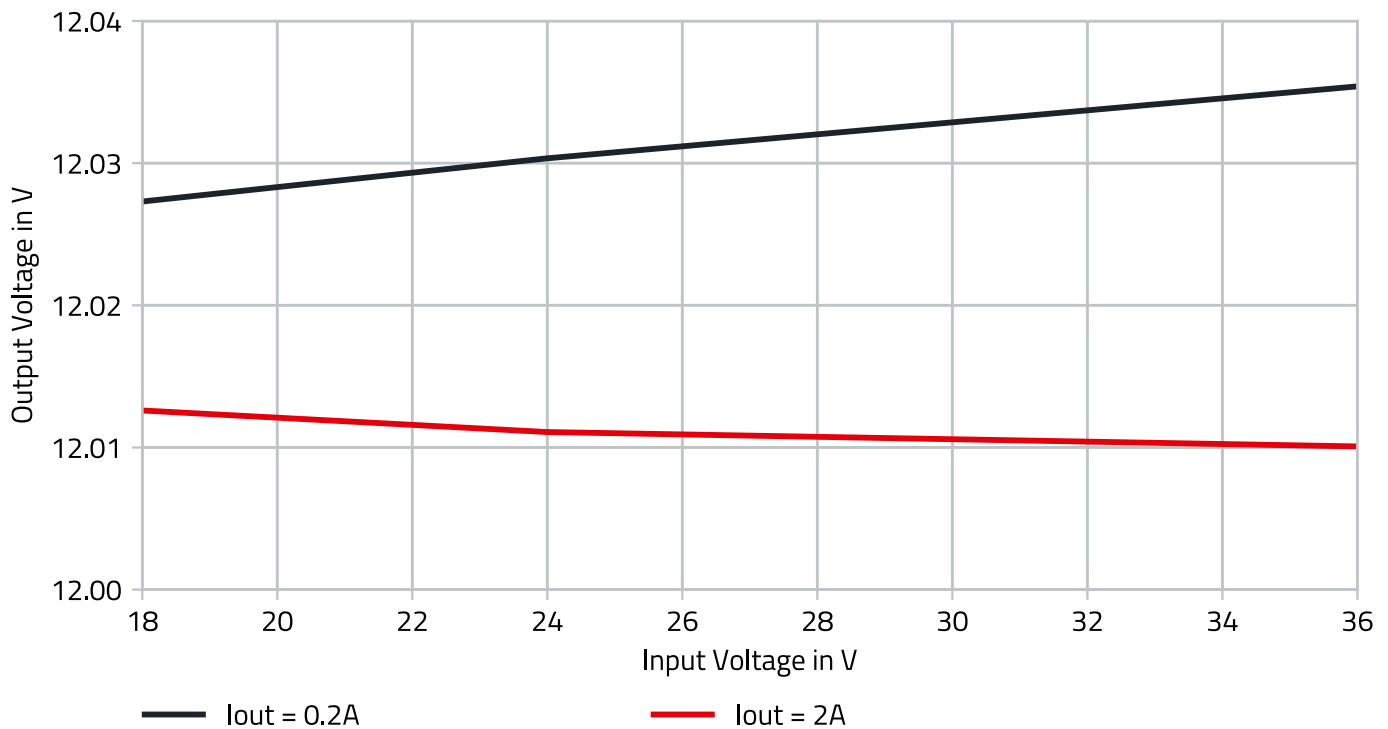

Figure 7: Line regulation.

### 13 BLOCK DIAGRAM

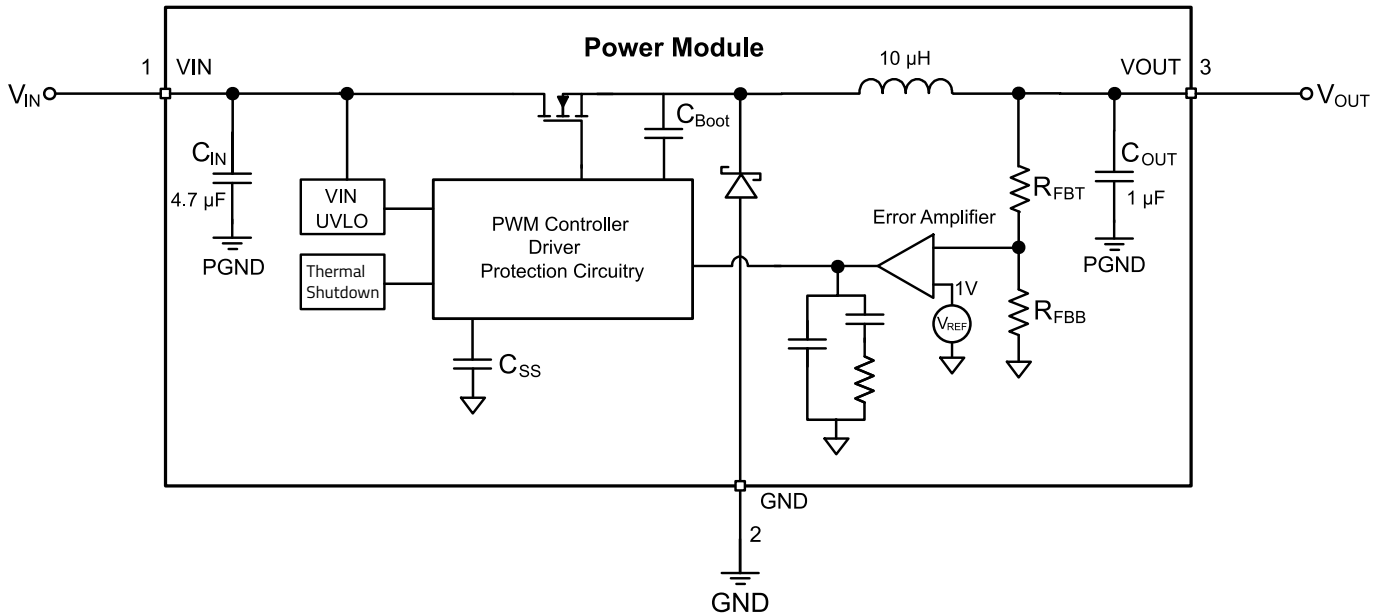

Figure 8: 173021236 block diagram.

### 14 CIRCUIT DESCRIPTION

The MagI<sup>3</sup>C power module 173021236 is a non-synchronous step-down regulator with integrated MOSFET, free-wheeling diode, power inductor, input and output capacitors. The control scheme is based on a current mode (CM) regulation loop.

The  $V_{OUT}$  of the regulator is divided by the internal feedback resistor network and fed into the error amplifier, which compares this signal with the internal 1V reference. The error amplifier controls the on-time of a fixed frequency pulse width generator, which drives the MOSFET.

The current mode architecture features a constant frequency during load steps. Only the on-time is modulated. It is internally compensated and stable with low ESR output capacitors. No external compensation network is required. This architecture supports fast transient response and very small output voltage ripple values (<60mV<sub>pp</sub>) are achieved.

## 15 OUTPUT VOLTAGE RIPPLE

The output voltage ripple depends on several parameters. The figure below shows the  $V_{OUT}$  ripple at full load using a 22 $\mu$ F MLCC output capacitor. An output voltage ripple of less than 60mV<sub>pp</sub> is measured under nominal conditions ( $V_{IN} = 24V$  and  $I_{OUT} = 2A$ ).

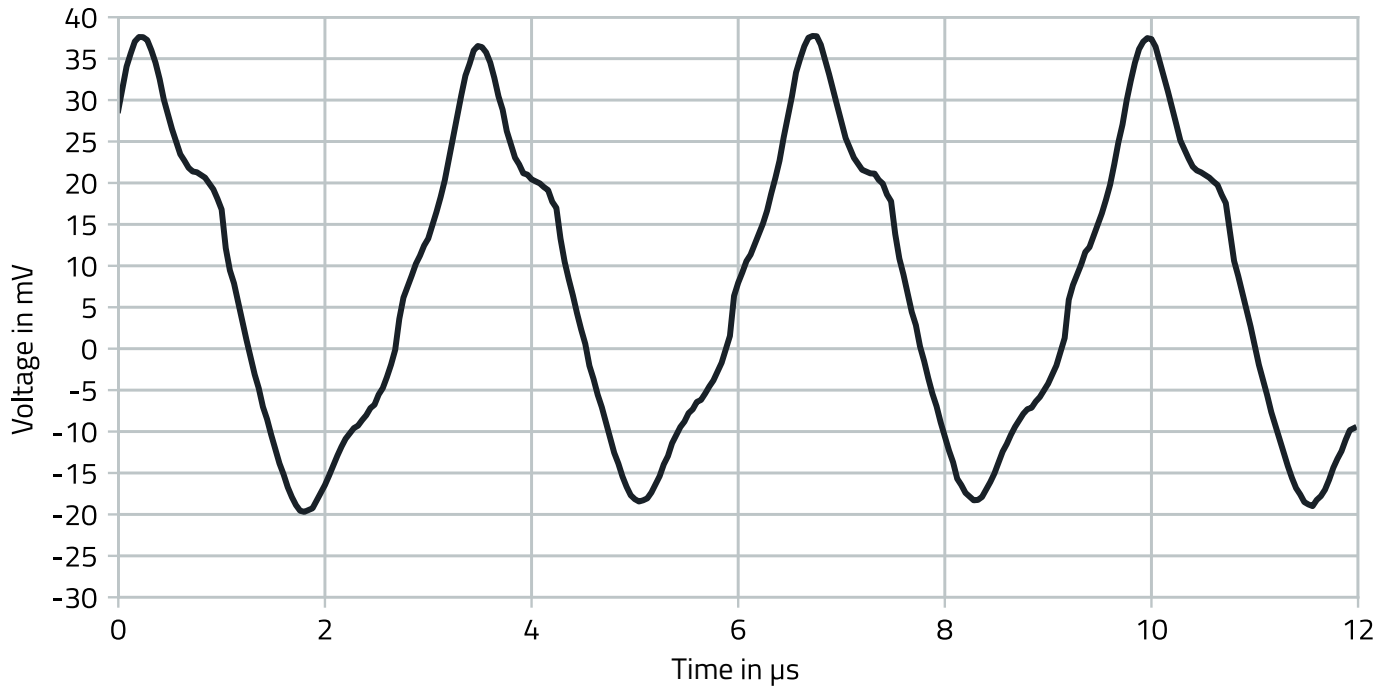

Figure 9: Output voltage ripple.

## 16 PROTECTION FEATURES

### 16.1 Soft-Start

An internal soft-start prevents the output voltage from overshooting during start up. The figures below show the start-up behavior of the power module.

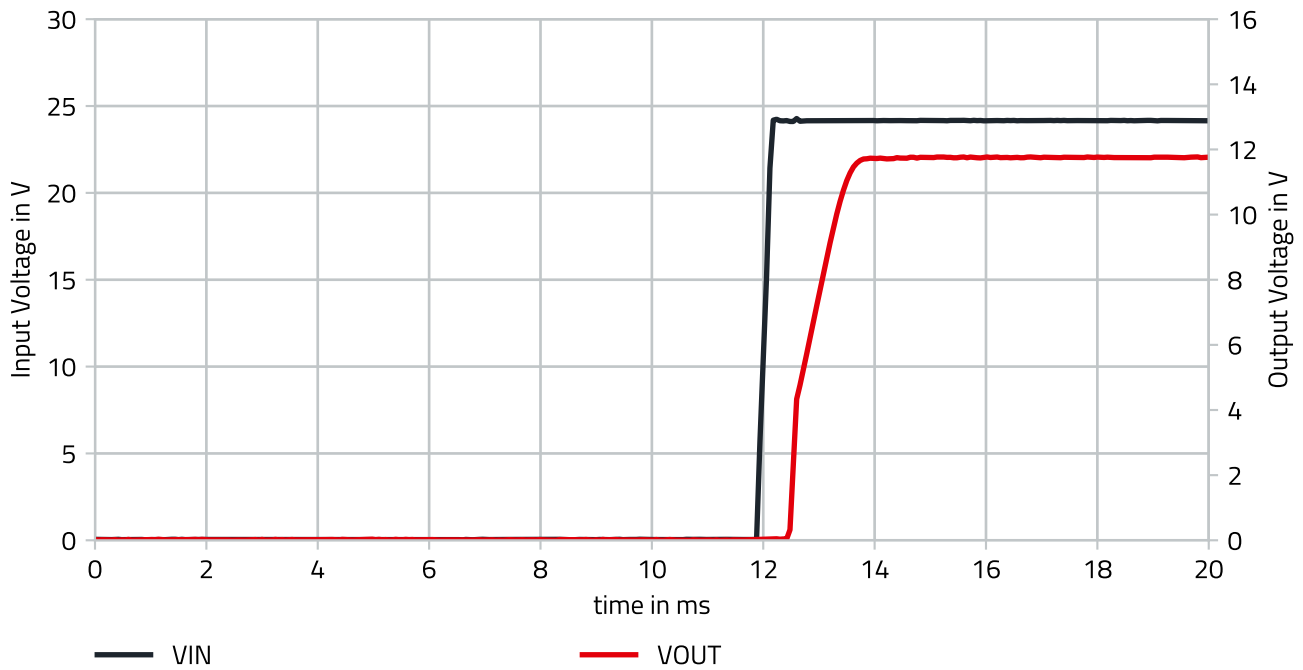

Figure 10: Soft-start,  $V_{IN} = 24V$ ,  $V_{OUT} = 12V$ ,  $I_{OUT} = 2A$ .

## 16.2 Over Temperature Protection (OTP)

Thermal protection helps to prevent catastrophic failures due to accidental device overheating. The junction temperature of the MagI<sup>3</sup>C power module should not be allowed to exceed its maximum ratings. Thermal protection is implemented by an internal thermal shutdown circuit which activates at 170°C (typ.), causing the device to enter a low power standby state. In this state, the MOSFET remains off, causing  $V_{OUT}$  to fall. When the junction temperature falls back below 158°C (typ.) (hysteresis is implemented)  $V_{OUT}$  rises smoothly and normal operation resumes.

## 16.3 Short Circuit Protection (SCP)

The short circuit protection is realized by hiccup mode. If the output voltage drops below a certain value the power module enters hiccup mode where the peak current of the high side switch is limited for 20ms. If the short circuit is not removed for 20ms, the power module turns off the high side switch for 94ms. If the short circuit maintains the power module runs under current limitation again for 20ms and the cycle repeats again. If the short circuit is removed, the power module soft starts and normal operation continues.

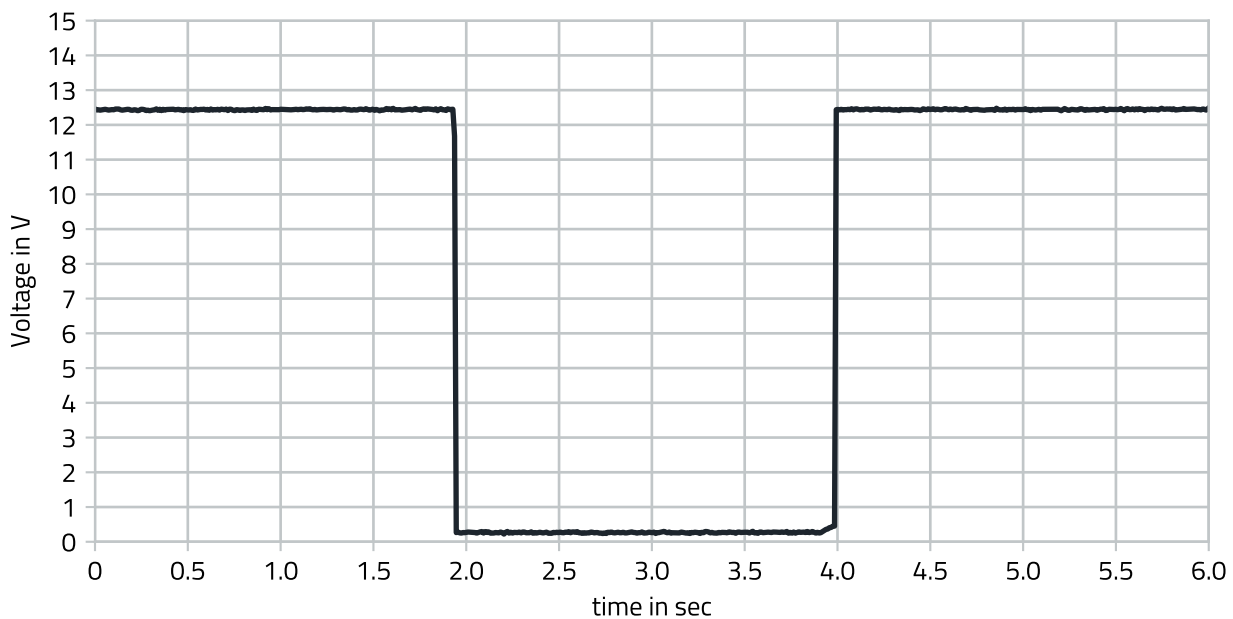

Figure 11: Short circuit protection.



#### 16.4 Over Current Protection (OCP)

For protection against load faults, the power module incorporates cycle by cycle current monitoring. During an overcurrent condition the output current is limited and the output voltage drops. When the overcurrent condition is removed, the output voltage returns to the nominal voltage.

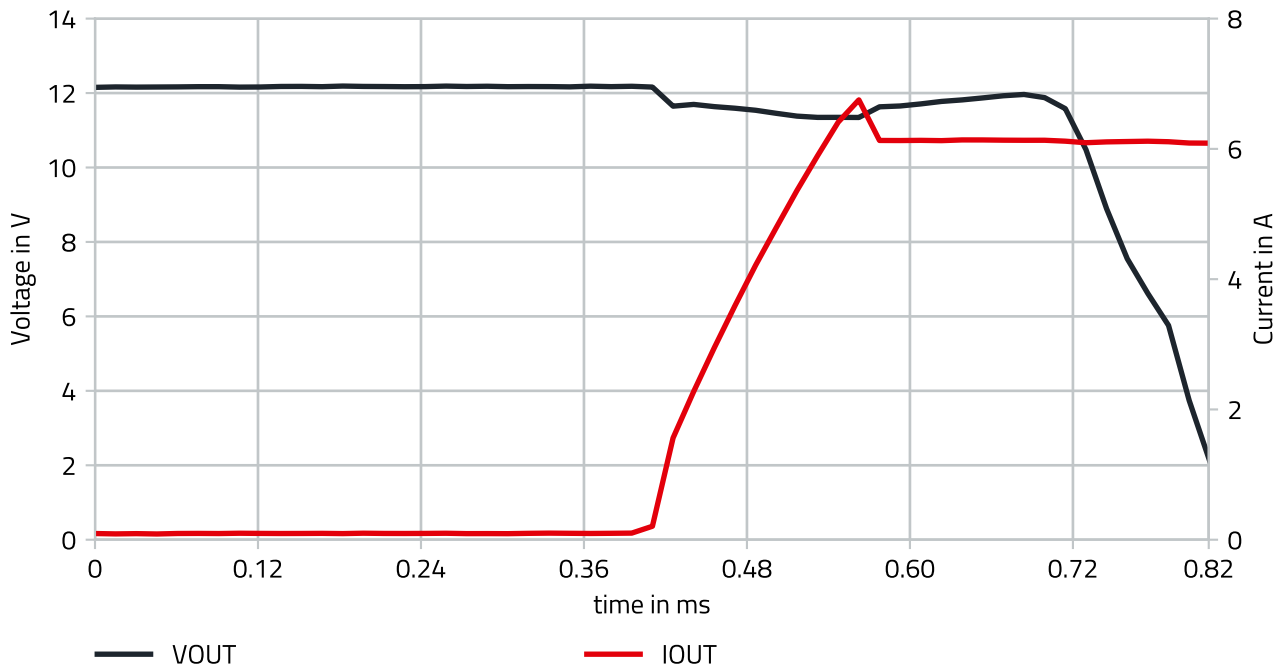

Figure 12: Over current protection,  $V_{IN} = 24V$ ,  $V_{OUT} = 12V$ ,  $I_{OUT} = 2A$ .

## 17 DESIGN EXAMPLE

The design example shows a possible solution for 24V to 12V with a maximum output current of 2A. All of the necessary components to fulfill the requirements of the CISPR-32 EMI conducted and radiated emissions tests are included in the design example. It passes the conducted emissions class B with 0.8m input and 1m output lines and passes the radiated emissions class B in a FAR at 3m measurement distance with 0.8m horizontal, 0.8m vertical input and 1m horizontal output lines. Filter components may be omitted depending on the requirements of the final application.

### 17.1 Layout

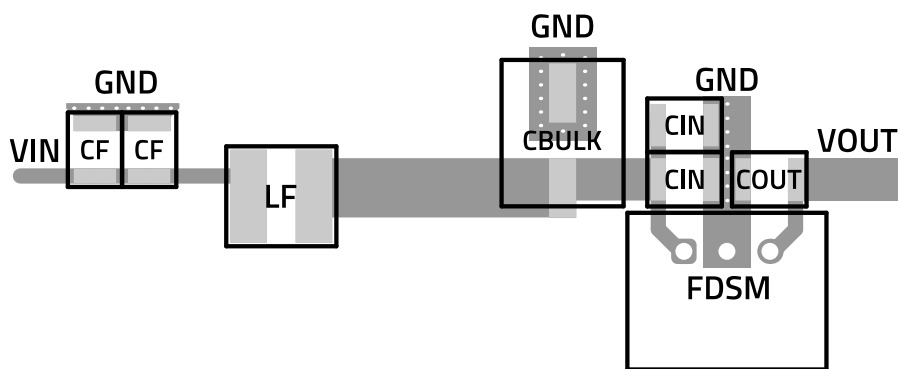

Figure 13: Layout recommendation.

The layout above has been evaluated to provide the optimal performance in terms of transient response, efficiency, ripple and EMI. The design footprint can be reduced at the expense of performance in these parameters.

The following recommendation should be followed when designing the layout:

1. The input and output capacitors should be placed as close as possible to the module pins.
2. The bulk capacitor should be placed close to the input capacitors of the module.
3. To avoid direct coupling of the DC/DC converter's E- and H-fields into connectors, the susceptible components and traces must be placed as far away from the module as possible.

## 17.2 Schematic

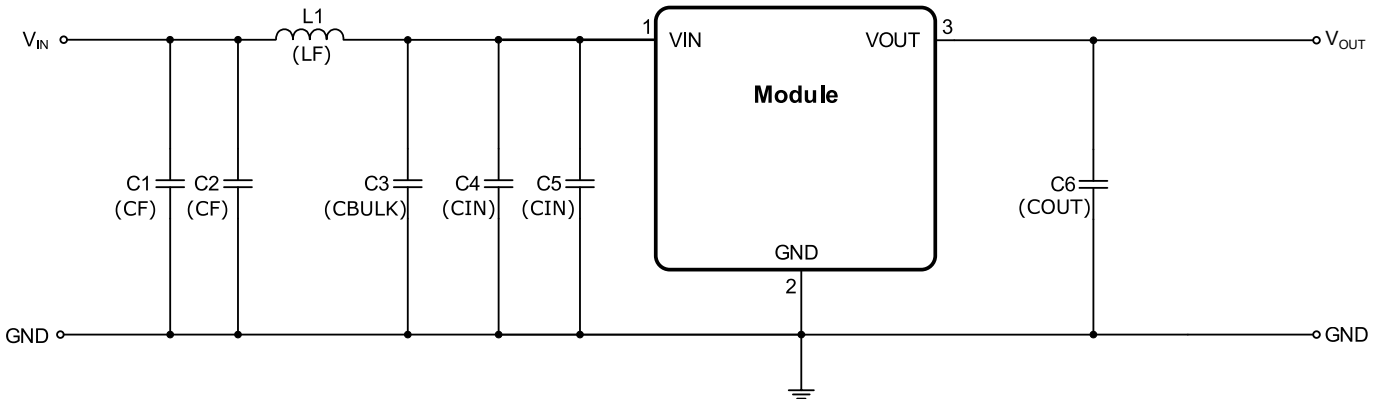

Figure 14: Design example schematic.

For optimal EMI performance, two filter capacitors, C1 and C2, one filter inductor, L1, two input capacitors, C4 and C5, and one output capacitor, C6 are recommended. For optimal electrical performance, two input capacitors, C4 and C5, and one output capacitor C6 are recommended. To damp possible input line oscillations the bulk capacitor, C3, is recommended.

## 17.3 Bill of Materials

Table 9: 173021236 design example bill of materials.

DESIGNATOR	DESCRIPTION	FUNCTION	QUANTITY	ORDER CODE	MANUFACTURER
U1	MagI <sup>3</sup> C Power Module	Power supply	1	173021236	WE
L1	Filter inductor, 4.7μH, PD2 family, I <sub>SAT</sub> = 5.5A, I <sub>R</sub> = 3A	Input Filter	1	744774047	WE
C1, C2	Ceramic chip capacitor 10μF/50V X7R, 1210	Input Filter	2	885012209073	WE
C3	Aluminum electrolytic capacitor 47μF/50V	Input Filter	1	865080645012	WE
C4, C5	Ceramic chip capacitor 10μF/50V X7R, 1210	Input Filter / Electrical Performance	2	885012209073	WE
C6	Ceramic chip capacitor 22μF/25V X7R, 1210	Output Filter / Electrical Performance	1	885012209074	WE

## 18 GENERATING NEGATIVE OUTPUT VOLTAGES

Many industrial applications require negative voltages. The 173021236 power module can easily provide a negative voltage using the circuit shown below. The module's VOUT pin is attached to the application ground and the module's GND pin is used to provide the output voltage. For low output voltage ripple, it is recommended to use an additional 22µF external capacitor at the output of the module.

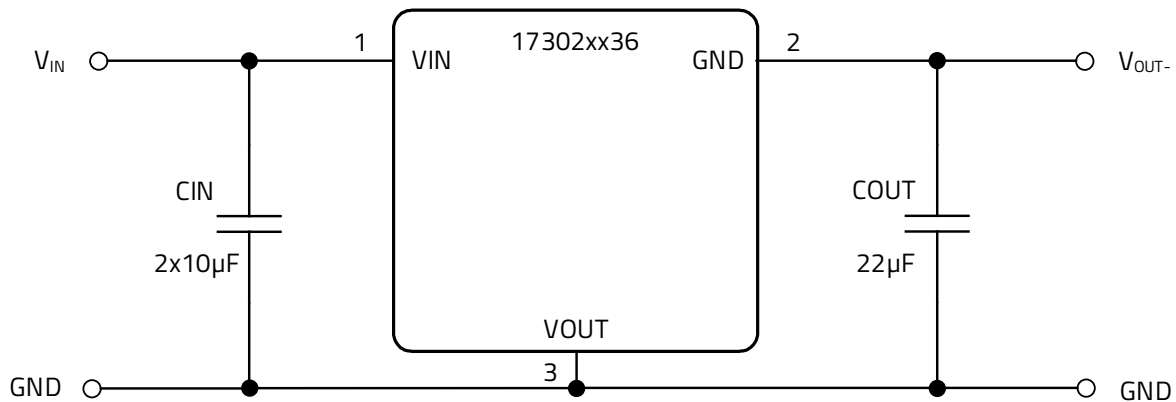

Figure 15: Negative output voltage schematic.

For additional information, please refer to the Application Note [ANS007b](#).

Table 10: Negative output voltage operating conditions.

Part Number	Minimum Vin (V)	Maximum Vin (V)	Maximum Iout (-mA)	Maximum Cout (µF)
173021236	8	23	600	220

## 19 GENERATING COMPLEMENTARY OUTPUT VOLTAGES

Another common requirement in industrial applications is to provide a complementary voltage (e.g.  $\pm 12V$ ). The circuit below shows how this target can be achieved by combining one of the 173021236 power modules used in a standard configuration (delivering a positive output voltage) with the above mentioned configuration for a negative output voltage. For low output voltage ripple, it is recommended to use an additional  $22\mu F$  external capacitor at the output of each module.

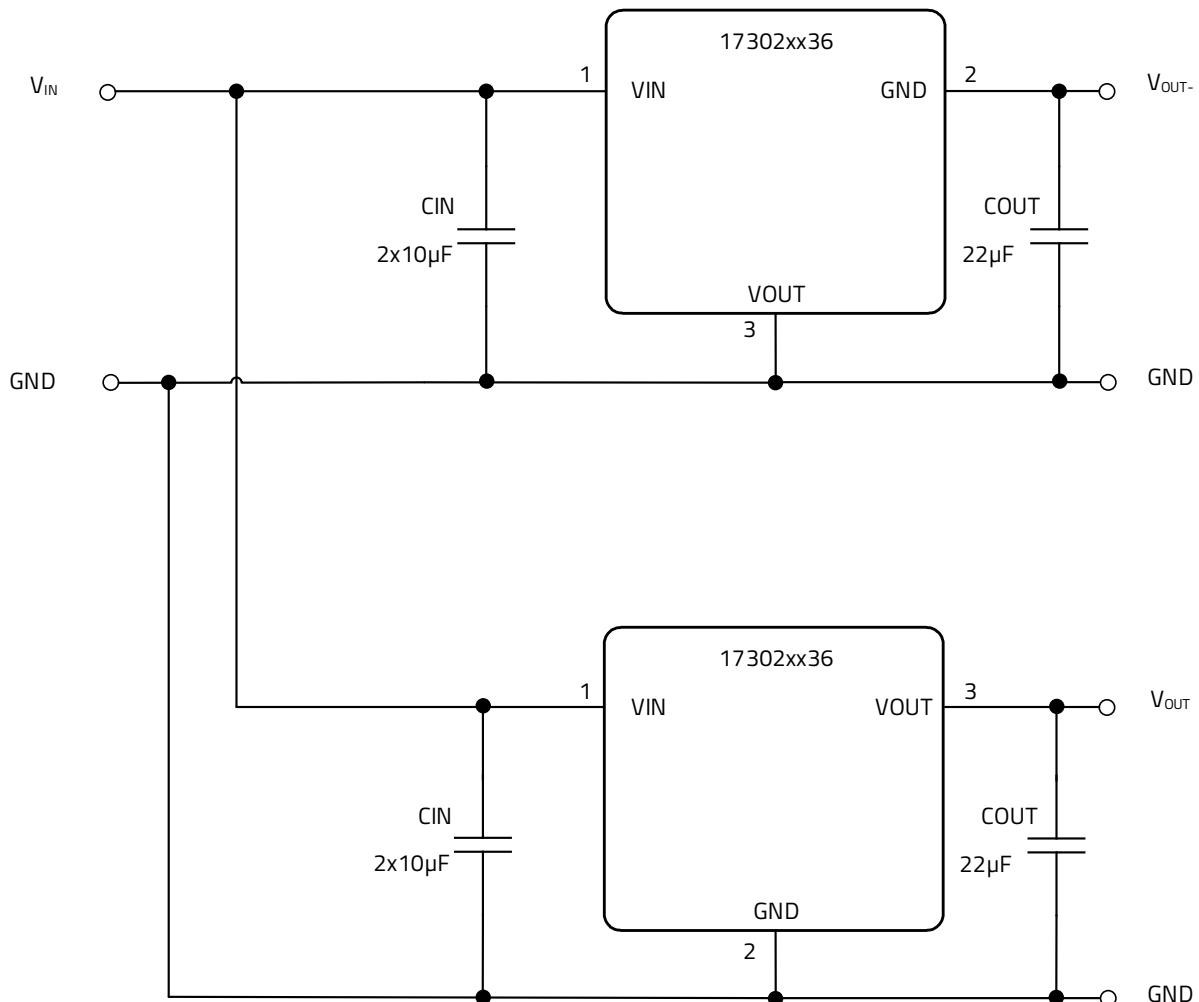

Figure 16: Complementary output voltage schematic.

## 20 HANDLING RECOMMENDATIONS

### 20.1 Solder Profile

Table 11: Wave solder profile.

Profile Feature	Old standard (Pb)	New (Pb-free)
Time within peak temperature $t_p$	max. 10s max. 5s each wave	max. 10s max. 5s each wave
Average ramp-up rate between $T_s$ and $T_p$	200°C/s	200°C/s
Final preheat temperature $T_s$	130°C/s	130°C/s
Peak temperature $T_p$	+235°C/s	+260°C/s
Ramp-down rate	-5°C/s	-5°C/s
Heating rate during preheat	4°C/s	4°C/s

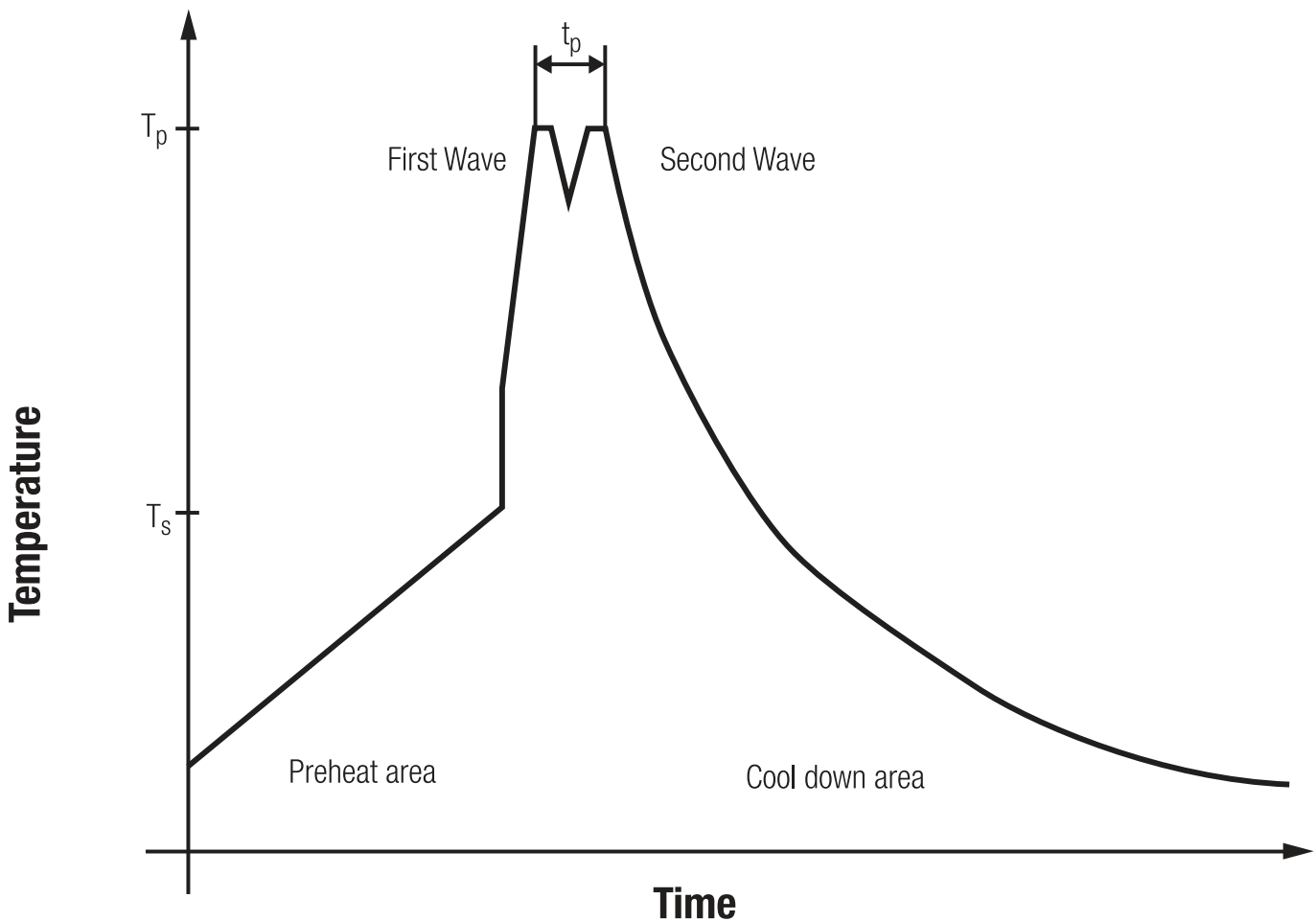

Figure 17: Solder profile.

## 21 PHYSICAL DIMENSIONS

### 21.1 Component

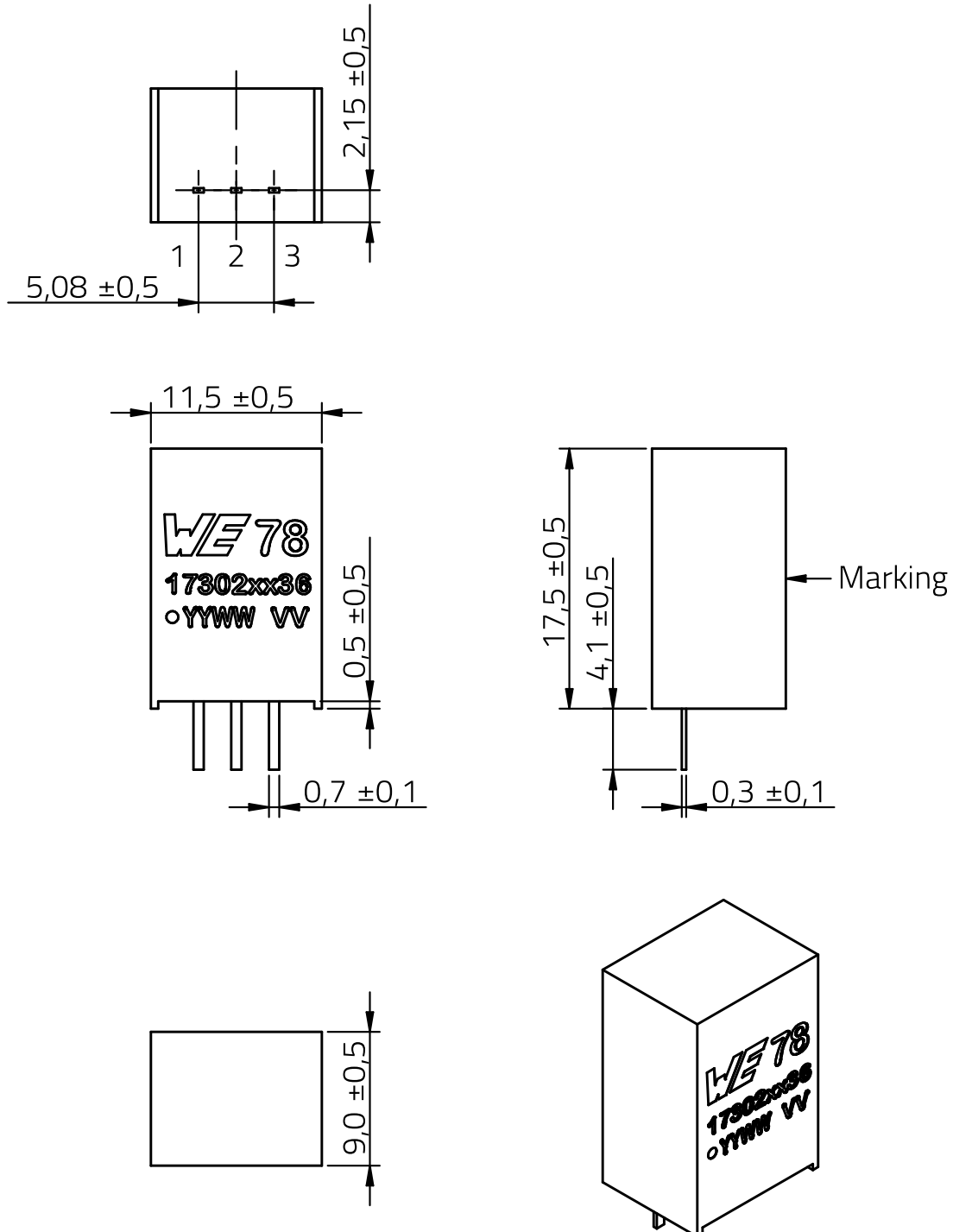

Figure 18: Physical dimensions.

All dimensions in mm

21.2 Recommended Drill Holes

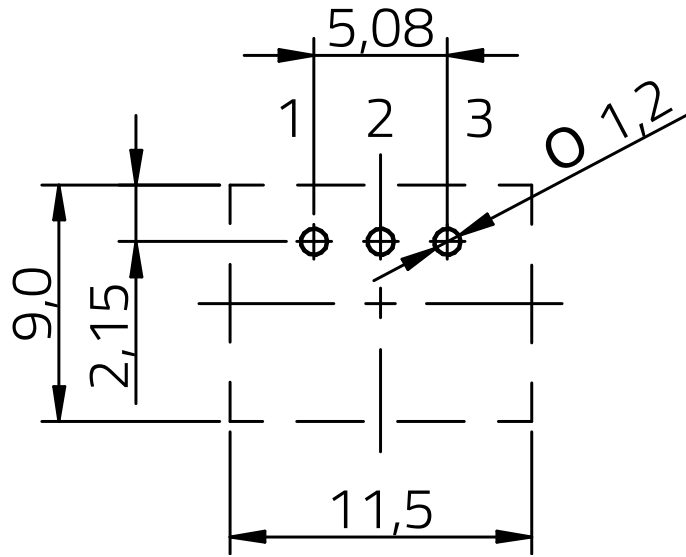

Figure 19: Recommended drill holes.

All dimensions in mm Tolerances  $\pm 0,1$ mm unless otherwise specified

21.3 Tube

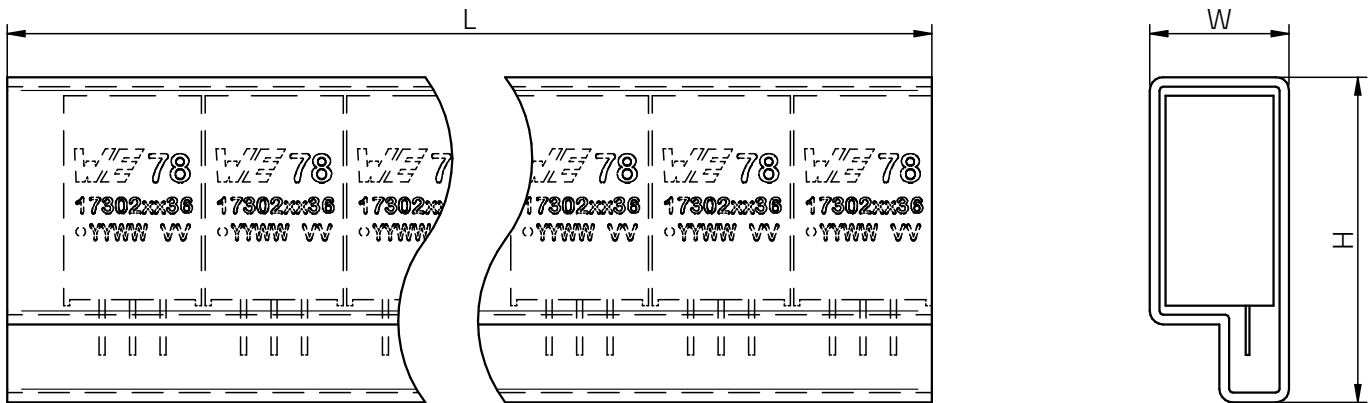

Figure 20: Tube.

Table 12: Packaging dimensions.

Dimension	L	W	H
Tolerance	typ.	typ.	typ.
Value	530mm	12mm	27.5mm



## 22 DOCUMENT HISTORY

Table 13: Document history.

<b>Revision</b>	<b>Date</b>	<b>Description</b>	<b>Comment</b>
1.0	October 2024	Initial data sheet release	

**23 LIST OF FIGURES**

1	Pinout. . . . .	4
2	Radiated EMI with input filter. . . . .	10
3	Conducted EMI with input filter. . . . .	10
4	Efficiency. . . . .	11
5	Thermal derating. . . . .	11
6	Load regulation. . . . .	12
7	Line regulation. . . . .	12
8	Block diagram. . . . .	13
9	Output voltage ripple. . . . .	14
10	Soft-start. . . . .	15
11	Short circuit protection. . . . .	16
12	Over current protection. . . . .	17
13	Layout recommendation. . . . .	18
14	Design example schematic. . . . .	19
15	Negative output voltage schematic. . . . .	20
16	Complementary output voltage schematic. . . . .	21
17	Solder profile. . . . .	22
18	Physical dimensions. . . . .	23
19	Recommended drill holes. . . . .	24
20	Tube. . . . .	24



24 LIST OF TABLES

1	Marking description. . . . .	4
2	Pin description. . . . .	4
3	Absolute maximum ratings. . . . .	6
4	Operating conditions. . . . .	6
5	Electrical specifications. . . . .	7
6	RoHS, REACH. . . . .	8
7	Reliability. . . . .	8
8	Package specifications. . . . .	8
9	Design example bill of materials. . . . .	19
10	Negative output voltage operating conditions. . . . .	20
11	Wave solder profile. . . . .	22
12	Packaging dimensions. . . . .	24
13	Document history. . . . .	25

## 25 CAUTIONS AND WARNINGS

The following conditions apply to all goods within the product series of MagI<sup>3</sup>C of Würth Elektronik eiSos GmbH & Co. KG:

### General:

- All recommendations according to the general technical specifications of the data-sheet have to be complied with.
- The usage and operation of the product within ambient conditions which probably alloy or harm the component surface has to be avoided.
- The responsibility for the applicability of customer specific products and use in a particular customer design is always within the authority of the customer. All technical specifications for standard products do also apply for customer specific products
- Residual washing varnish agent that is used during the production to clean the application might change the characteristics of the body, pins or termination. The washing varnish agent could have a negative effect on the long term function of the product. Direct mechanical impact to the product shall be prevented as the material of the body, pins or termination could flake or in the worst case it could break. As these devices are sensitive to electrostatic discharge customer shall follow proper IC Handling Procedures.
- Customer acknowledges and agrees that it is solely responsible for compliance with all legal, regulatory and safety-related requirements concerning its products, and any use of Würth Elektronik eiSos GmbH & Co. KG components in its applications, notwithstanding any applications-related information or support that may be provided by Würth Elektronik eiSos GmbH & Co. KG.
- Customer represents and agrees that it has all the necessary expertise to create and implement safeguards which anticipate dangerous consequences of failures, monitor failures and their consequences lessen the likelihood of failures that might cause harm and take appropriate remedial actions
- Customer will fully indemnify Würth Elektronik eiSos and its representatives against any damages arising out of the use of any Würth Elektronik eiSos GmbH & Co. KG components in safety-critical applications

### Product specific:

Follow all instructions mentioned in the datasheet, especially:

- The solder profile has to comply with the technical reflow or wave soldering specification, otherwise this will void the warranty.
- All products are supposed to be used before the end of the period of 12 months based on the product date-code.
- Violation of the technical product specifications such as exceeding the absolute maximum ratings will void the warranty.
- It is also recommended to return the body to the original moisture proof bag and reseal the moisture proof bag again.
- ESD prevention methods need to be followed for manual handling and processing by machinery.

### Disclaimer:

This electronic component has been designed and developed for usage in general electronic equipment only. This product is not authorized for use in equipment where a higher safety standard and reliability standard is especially required or where a failure of the product is reasonably expected to cause severe personal injury or death, unless the parties have executed an agreement specifically governing such use. Moreover Würth Elektronik eiSos GmbH & Co. KG products are neither designed nor intended for use in areas such as military, aerospace, aviation, nuclear control, submarine, transportation (automotive control, train control, ship control), transportation signal, disaster prevention, medical, public information network etc. Würth Elektronik eiSos GmbH & Co. KG must be informed about the intent of such usage before the design-in stage. In addition, sufficient reliability evaluation checks for safety must be performed on every electronic component which is used in electrical circuits that require high safety and reliability functions or performance. These cautions and warnings comply with the state of the scientific and technical knowledge and are believed to be accurate and reliable. However, no responsibility is assumed for inaccuracies or incompleteness.

## 26 IMPORTANT NOTES

### General Customer Responsibility

Some goods within the product range of Würth Elektronik eiSos GmbH & Co. KG contain statements regarding general suitability for certain application areas. These statements about suitability are based on our knowledge and experience of typical requirements concerning the areas, serve as general guidance and cannot be estimated as binding statements about the suitability for a customer application. The responsibility for the applicability and use in a particular customer design is always solely within the authority of the customer. Due to this fact it is up to the customer to evaluate, where appropriate to investigate and decide whether the device with the specific product characteristics described in the product specification is valid and suitable for the respective customer application or not. Accordingly, the customer is cautioned to verify that the datasheet is current before placing orders.

### Customer Responsibility Related to Specific, in Particular Safety-Relevant, Applications

It has to be clearly pointed out that the possibility of a malfunction of electronic components or failure before the end of the usual lifetime cannot be completely eliminated in the current state of the art, even if the products are operated within the range of the specifications. In certain customer applications requiring a very high level of safety and especially in customer applications in which the malfunction or failure of an electronic component could endanger human life or health it must be ensured by most advanced technological aid of suitable design of the customer application that no injury or damage is caused to third parties in the event of malfunction or failure of an electronic component.

### Best Care and Attention

Any product-specific notes, warnings and cautions must be strictly observed. Any disregard will result in the loss of warranty.

### Customer Support for Product Specifications

Some products within the product range may contain substances which are subject to restrictions in certain jurisdictions in order to serve specific technical requirements. Necessary information is available on request. In this case the field sales engineer or the internal sales person in charge should be contacted who will be happy to support in this matter.

### Product R&D

Due to constant product improvement product specifications may change from time to time. As a standard reporting procedure of the Product Change Notification (PCN) according to the JEDEC-Standard we inform about minor and major changes. In case of further queries regarding the PCN, the field sales engineer or the internal sales person in charge should be contacted. The basic responsibility of the customer as per Section 1 and 2 remains unaffected.

### Product Life Cycle

Due to technical progress and economical evaluation we also reserve the right to discontinue production and delivery of products. As a standard reporting procedure of the Product Termination Notification (PTN) according to the JEDEC Standard we will inform at an early stage about inevitable product discontinuance. According to this we cannot guarantee that all products within our product range will always be available. Therefore it needs to be verified with the field sales engineer or the internal sales person in charge about the current product availability expectancy before or when the product for application design-in disposal is considered. The approach named above does not apply in the case of individual agreements deviating from the foregoing for customer-specific products.

### Property Rights

All the rights for contractual products produced by Würth Elektronik eiSos GmbH & Co. KG on the basis of ideas, development contracts as well as models or templates that are subject to copyright, patent or commercial protection supplied to the customer will remain with Würth Elektronik eiSos GmbH & Co. KG. Würth Elektronik eiSos GmbH & Co. KG does not warrant or represent that any license, either expressed or implied, is granted under any patent right, copyright, mask work right, or other intellectual property right relating to any combination, application, or process in which Würth Elektronik eiSos GmbH & Co. KG components or services are used.

### General Terms and Conditions

Unless otherwise agreed in individual contracts, all orders are subject to the current version of the "General Terms and Conditions of Würth Elektronik eiSos Group", last version available at [www.we-online.com](http://www.we-online.com).