

Maximum Input 74.5V / 0.5A / Fixed Output 12V

DESCRIPTION

The FDSM series of the MagI³C Power Module family is a fixed output voltage, fully integrated DC-DC power supply including the controller IC, inductor and capacitors all in one package.

For optimal performance the module is recommended for use with an external input capacitor, reducing design effort and complexity to a minimum.

The FDSM ensures fast time to market and low development costs.

The module is specially suited for high transient 48V bus applications such as industrial motor drive control systems.

The 173951275 module achieves an efficiency up to 90%.

The standard THT (11.5 x 8.5 x 17.5mm) package allows for easy assembly.

TYPICAL APPLICATIONS

- Point-of-Load DC-DC applications
- Replacement for linear regulators
- Interface and microcontroller supplies
- General purpose
- 48V rail logistics & automation applications

FEATURES

- Peak efficiency up to 90%
- Current capability up to 0.5A
- Input voltage up to 74.5V
- No minimum load required
- Partially integrated input and output capacitors
- Integrated inductor
- Low output voltage ripple (<50mV_{pp})
- PFM/PWM mode
- Internal soft-start
- Thermal shutdown
- Short circuit protection
- Cycle by cycle current limit
- Pin compatible with the FDSM power modules series
- Ambient temperature range: -40°C to 85°C
- RoHS & REACH compliant
- Complies with EN55032 (CISPR-32) class B conducted and radiated emissions standard



TYPICAL CIRCUIT DIAGRAM

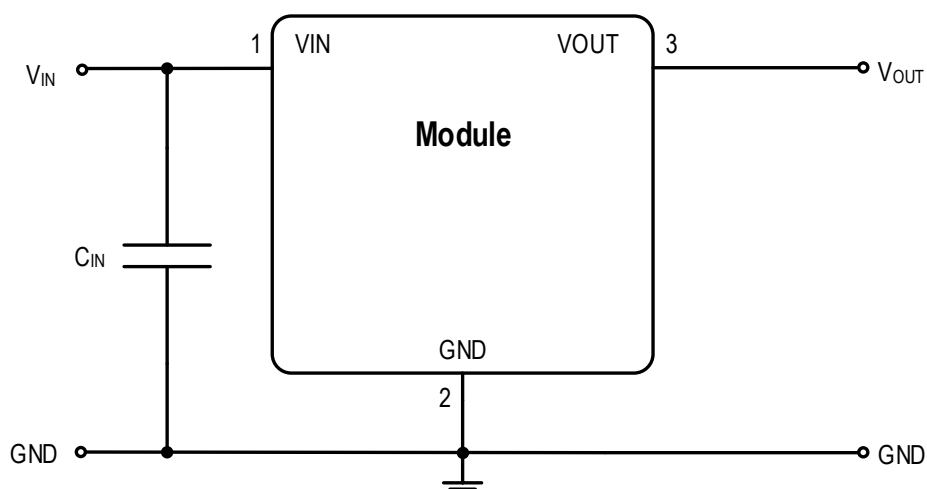

CONTENTS

1	PINOUT	4
2	ORDERING INFORMATION	5
3	PINOUT COMPATIBLE FAMILY MEMBERS	5
4	SALES INFORMATION	5
5	ABSOLUTE MAXIMUM RATINGS	6
6	OPERATING CONDITIONS	6
7	ELECTRICAL SPECIFICATIONS	7
8	RoHS, REACH	8
9	RELIABILITY	8
10	PACKAGE SPECIFICATIONS	8
11	NOTES	8
12	TYPICAL PERFORMANCE CURVES	9
12.1	Radiated and Conducted Emissions EN55032 (CISPR-32) Class B Compliance	9
12.1.1	Radiated Emissions EN55032 (CISPR-32) Class B Compliant Test Setup	9
12.1.2	Conducted Emissions EN55032 (CISPR-32) Class B Compliant Test Setup	9
12.1.3	Radiated and Conducted Emissions	10
12.2	DC Performance Curves	11
12.2.1	Efficiency	11
12.2.2	Thermal Derating	11
12.2.3	Load Regulation	12
12.2.4	Line Regulation	12
13	BLOCK DIAGRAM	13
14	CIRCUIT DESCRIPTION	13
15	OUTPUT VOLTAGE RIPPLE	14
16	PROTECTION FEATURES	15
16.1	Soft-Start	15
16.2	Over Temperature Protection (OTP)	16
16.3	Short Circuit Protection (SCP)	16
16.4	Over Current Protection (OCP)	17
17	DESIGN EXAMPLE	18
17.1	Layout	18
17.2	Schematic	19
17.3	Bill of Materials	19
18	OUTPUT VOLTAGE FEATURES	20
19	HANDLING RECOMMENDATIONS	21
19.1	Soldering Profile	21
20	PHYSICAL DIMENSIONS	22
20.1	Component	22
20.2	Recommended Drill Holes	23
20.3	Tube	23

173951275

MagI³C Power Module

WPME-FDSM - Fixed Step Down Regulator Module



**WÜRTH
ELEKTRONIK**
MORE THAN
YOU EXPECT

21 DOCUMENT HISTORY	24
22 LIST OF FIGURES	25
23 LIST OF TABLES	26
24 CAUTIONS AND WARNINGS	27
25 IMPORTANT NOTES	28

1 PINOUT (PACKAGE TYPE B)

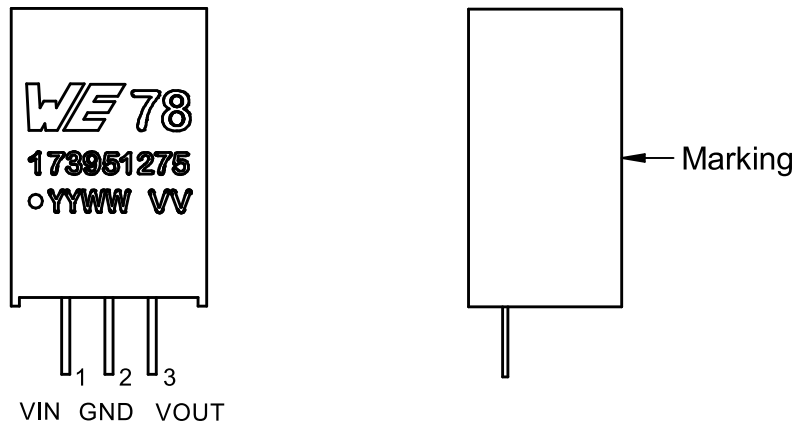

Figure 1: Pinout type B package (pins are located at the back).

Table 1: Marking description.

MARKING	DESCRIPTION
WE	Würth Elektronik eiSos GmbH & Co. KG
78	Indicates compatibility with 78xx linear regulator
173951275	Order code
YY	Year
WW	Calendar week
VV	Output voltage

Table 2: Pin description.

SYMBOL	NUMBER	TYPE	DESCRIPTION
VIN	1	Power	The supply input pin is a terminal for an input voltage source. It is recommended to use 2x10 μ F/100V input capacitors.
GND	2	Power	Ground pin; reference for V_{IN} and V_{OUT} .
VOUT	3	Power	Regulated output voltage pin. There is no need for an external output capacitor.

2 ORDERING INFORMATION

ORDER CODE	SPECIFICATIONS	PACKAGE	PACKAGING UNIT
173951275	74.5V / 0.5A / 12V Vout	SIP-3 Type B	Tube with 42 pieces

3 PINOUT COMPATIBLE FAMILY MEMBERS

Table 3: Pinout compatible family members.

ORDER CODE	SPECIFICATIONS	PACKAGE	PACKAGING UNIT	
173950378	28V / 0.5A / 3.3V Vout	SIP-3 Type F	Tube with 42 pieces	
173950578	28V / 0.5A / 5V Vout			
173010378	28V / 1A / 3.3V Vout			
173010578	28V / 1A / 5V Vout			
173010342	42V / 1A / 3.3V Vout			
173010542	42V / 1A / 5V Vout			
173950336	36V / 0.5A / 3.3V Vout		SIP-3 Type B	Tube with 43 pieces
173950536	36V / 0.5A / 5V Vout			
173951236	36V / 0.5A / 12V Vout			
173951536	36V / 0.5A / 15V Vout			
173010335	36V / 1A / 3.3V Vout			
173010535	36V / 1A / 5V Vout			
173011235	36V / 1A / 12V Vout	SIP-3 Type B		Tube with 44 pieces
173011535	36V / 1A / 15V Vout			
173020336	36V / 2A / 3.3V Vout			
173020536	36V / 2A / 5V Vout			
173021236	36V / 2A / 12V Vout			Tube with 42 pieces
173950575	74.5V / 0.5A / 5V Vout			
173951275	74.5V / 0.5A / 12V Vout			

4 SALES INFORMATION

Table 4: Sales information.

SALES CONTACT
<p>Würth Elektronik eiSos GmbH & Co. KG EMC and Inductive Solutions Max-Eyth-Str. 1 74638 Waldenburg Germany Tel. +49 (0) 7942 945 0 www.we-online.com/powermodules Technical support: wpme-support@we-online.com</p>

5 ABSOLUTE MAXIMUM RATINGS

Caution:

Exceeding the listed absolute maximum ratings may affect the device negatively and may cause permanent damage.

Table 5: Absolute maximum ratings.

SYMBOL	PARAMETER	LIMIT		UNIT
		MIN ⁽¹⁾	MAX ⁽¹⁾	
V _{IN}	Input pin voltage	-0.3	100	V
V _{OUT}	Output pin voltage	-0.3	16	V
T _{storage}	Assembled, non-operating storage temperature	-40	125	°C
V _{esd}	ESD Voltage (Human Body Model), according to EN61000-4-2 ⁽⁴⁾	-4	4	kV

6 OPERATING CONDITIONS

Operating conditions are conditions under which the device is intended to be functional. All values are referenced to GND.

MIN and MAX limits are valid for the recommended ambient temperature range of -40°C to 85°C. Typical values represent statistically the utmost probable values at the following conditions: V_{IN}= 18V to 74.5V, I_{OUT}= 0.5A, T_A = 25°C, unless otherwise noted.

Table 6: Operating conditions.

SYMBOL	PARAMETER	MIN ⁽¹⁾	TYP ⁽³⁾	MAX ⁽¹⁾	UNIT
V _{IN}	Input Voltage	18	-	74.5	V
T _a	Ambient temperature range	-40	-	85 ⁽²⁾	°C
I _{OUT}	Nominal output current ⁽⁵⁾	-	-	0.5	A
C _{OUT MAX}	Maximal output capacitance	-	-	100	μF

7 ELECTRICAL SPECIFICATIONS

Caution:

MIN and MAX limits are valid for the recommended ambient temperature range of -40°C to 85°C. Typical values represent statistically the utmost probable values at the following conditions: $V_{IN} = 48V$, $V_{OUT} = 12V$, $I_{OUT} = 0.5A$, $T_A = 25^\circ C$, unless otherwise noted.

Table 7: Electrical specifications.

SYMBOL	PARAMETER	TEST CONDITIONS	LIMIT			UNIT
			MIN ⁽¹⁾	TYP ⁽³⁾	MAX ⁽¹⁾	
Output Current						
I_{CL}	Current limit threshold		—	1.2	—	A
Output Voltage						
V_{OUT}	Regulated output voltage		—	12	—	V
	Line regulation		—	—	2.5	%
	Load Regulation	10% to 100% load	—	—	2.0	%
	Total output voltage regulation		—	—	3	%
	Output voltage ripple			—	75	—
Switching Frequency						
f_{SW}	Switching frequency		—	350	—	kHz
Input Current						
I_{IN}	No load input current	Operating, switching	—	0.2	—	mA
Efficiency						
η	Efficiency		—	90	—	%

8 RoHS, REACH

Table 8: RoHS, REACH.

RoHS directive		Directive 2011/65/EU of the European Parliament and the Council of June 8th, 2011 on the restriction of the use of certain hazardous substances in electrical and electronic equipment.
REACH directive		Directive 1907/2006/EU of the European Parliament and the Council of June 1st, 2007 regarding the Registration, Evaluation, Authorization and Restriction of Chemicals (REACH).

9 RELIABILITY

Table 9: Reliability.

SYMBOL	PARAMETER	TEST CONDITIONS	TYP ⁽³⁾	UNIT
MTBF ⁽⁶⁾	Mean Time Between Failures	MIL-HDBK-217F, 25 °C	6849 · 10 ³	h
		MIL-HDBK-217F, 85 °C	1337 · 10 ³	h

10 PACKAGE SPECIFICATIONS

Table 10: Package specifications.

ITEM	PARAMETER	TYP ⁽³⁾	UNIT
Case	Black flame-retardant and heat-resistant plastic (UL94 V-0)	-	-
Potting material	Silicone, UL94V-0	-	-
Weight		4	g
Vibration	5g for 20 min	MIL-STD-202, Method 204	

11 NOTES

- (1) Min and Max limits are 100% production tested at 25 °C. Limits over the operating temperature range are guaranteed through correlation using Statistical Quality Control (SQC) methods.
- (2) Measured without heatsink. Natural convection (0 - 20LFM / 0- 0.1m/s) on a 57 x 35mm two layer test board, with 35µm (1 ounce) copper.
- (3) Typical numbers are valid at 25 °C ambient temperature and represent statistically the utmost probable values assuming a Gaussian distribution.
- (4) The human body model is a 100pF capacitor discharged through a 1.5kΩ resistor into each pin. Test method is per JESD-22-114.
- (5) Depending on ambient temperature; see [THERMAL DERATING](#).
- (6) MIL-HDBK-217F; GB Ground, Benign: Non mobile, temperature and humidity controlled environments readily accessible to maintenance; includes laboratory instruments and test equipment, medical electronic equipment, business and scientific computer complexes, and missiles and support equipment in ground silos; MTBF value is referring to 173951275.

12 TYPICAL PERFORMANCE CURVES

If not otherwise specified, the following conditions apply: $V_{IN} = 48V$; $V_{OUT} = 12V$; $I_{OUT} = 0.5A^{(5)}$; $T_{AMB} = 25^{\circ}C$.

12.1 Radiated and Conducted Emissions EN55032 (CISPR-32) Class B Compliance

The 173951275 power module is tested with a standard EMC configuration (1m wire between the module and the load) to give more realistic information about implementation in the applications. The test setup is based on CISPR-16 with the limit values taken from CISPR-32.

Measured with module on the design example shown in chapter [DESIGN EXAMPLE](#) in a Fully Anechoic Room (FAR) at 3m antenna distance.

12.1.1 Radiated Emissions EN55032 (CISPR-32) Class B Compliant Test Setup

- Measured in a Fully Anechoic Room (FAR) at 3m antenna distance
- Input wire length: 160cm (80cm horizontal + 80cm vertical)
- Output wire length: 1m

12.1.2 Conducted Emissions EN55032 (CISPR-32) Class B Compliant Test Setup

- Measurement input wire length: 80cm
- Output wire length: 1m

12.1.3 Radiated and Conducted Emissions

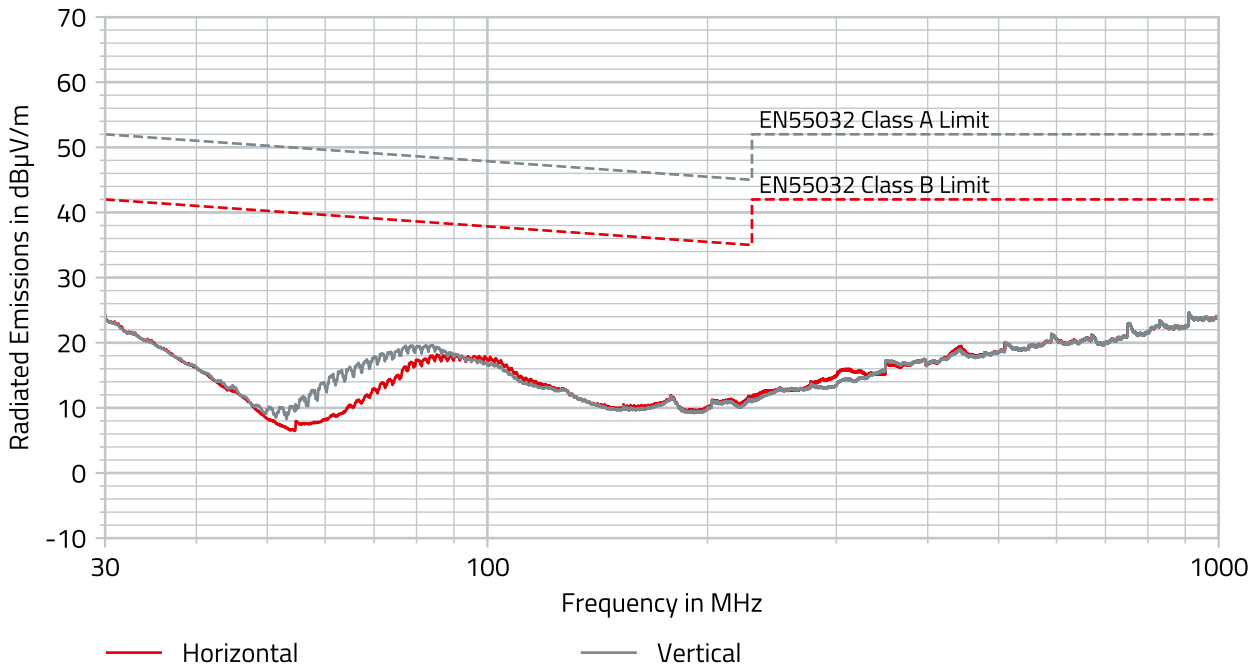

Figure 2: Radiated EMI with input filter.

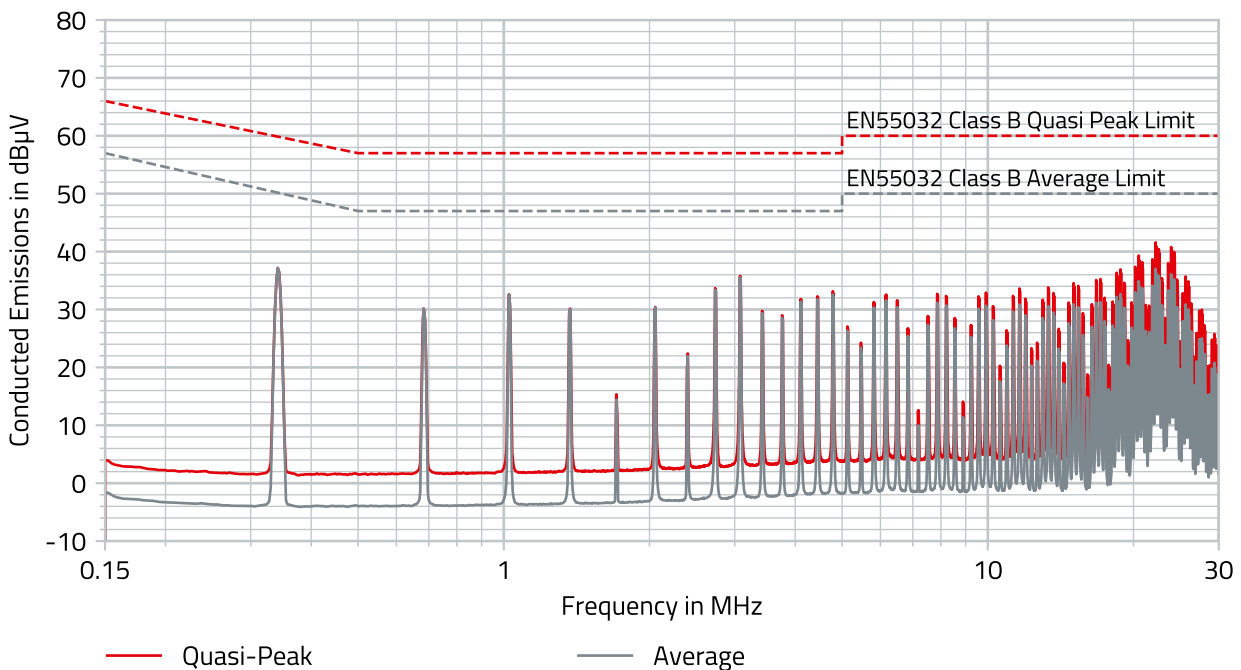

Figure 3: Conducted EMI with input filter.

12.2 DC PERFORMANCE CURVES

12.2.1 EFFICIENCY

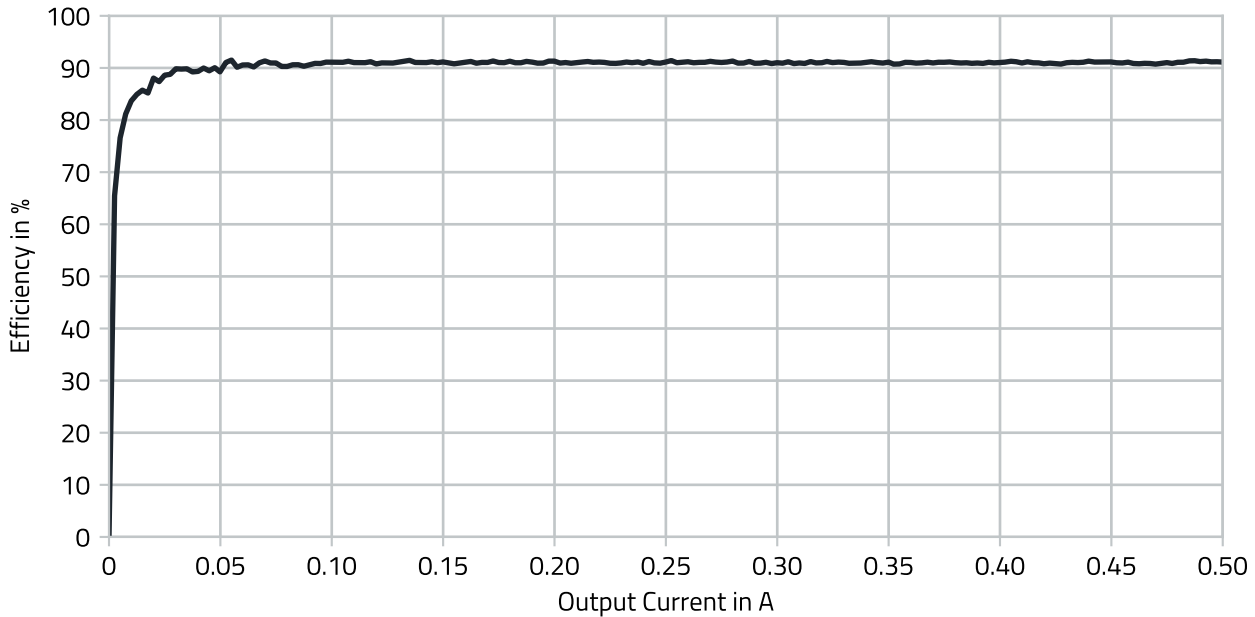

Figure 4: Efficiency.

12.2.2 THERMAL DERATING

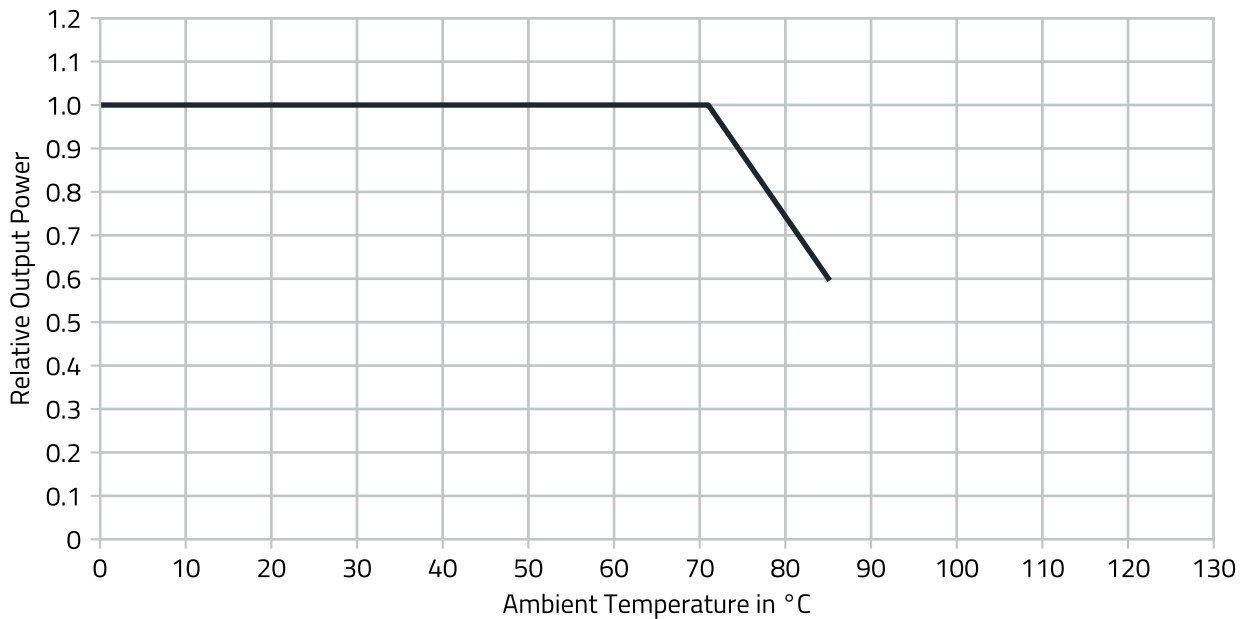

Figure 5: Thermal derating.

12.2.3 LOAD REGULATION

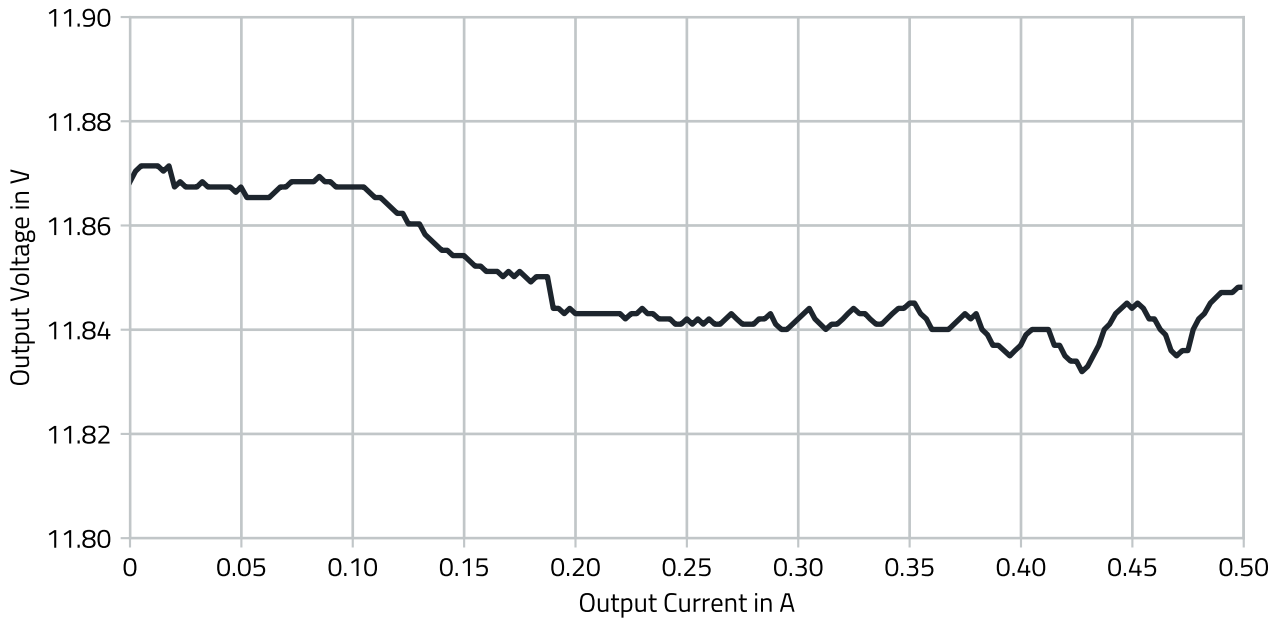

Figure 6: Load regulation.

12.2.4 LINE REGULATION

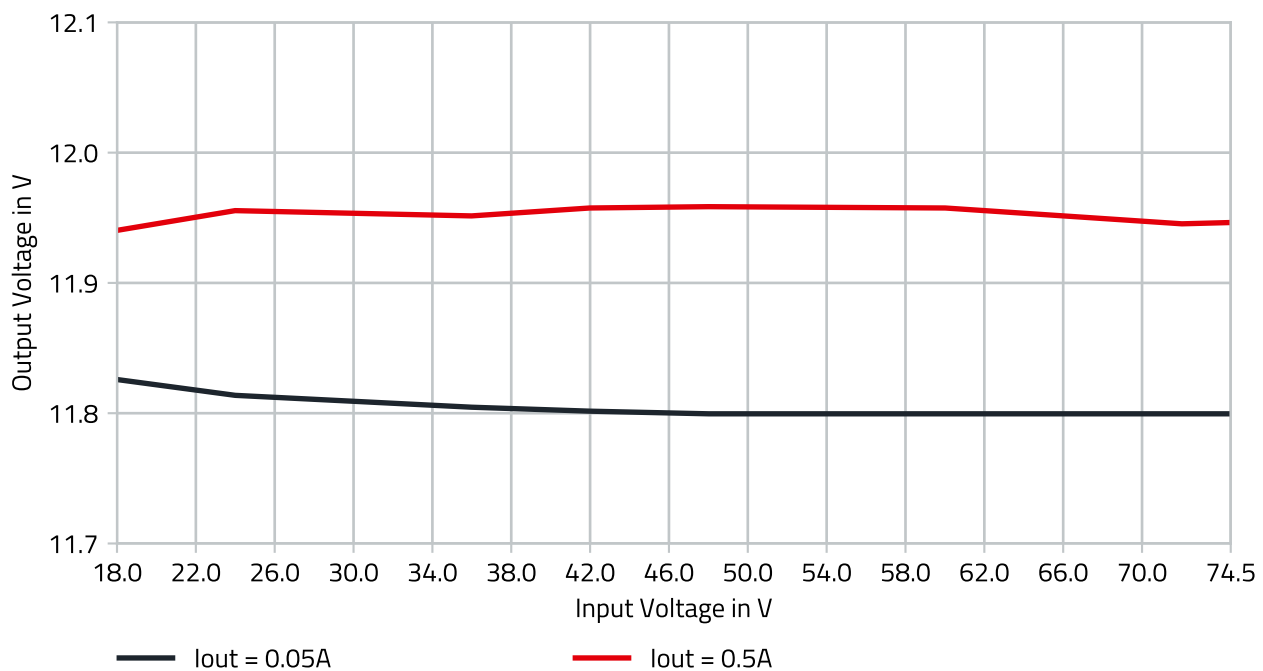

Figure 7: Line regulation.

13 BLOCK DIAGRAM

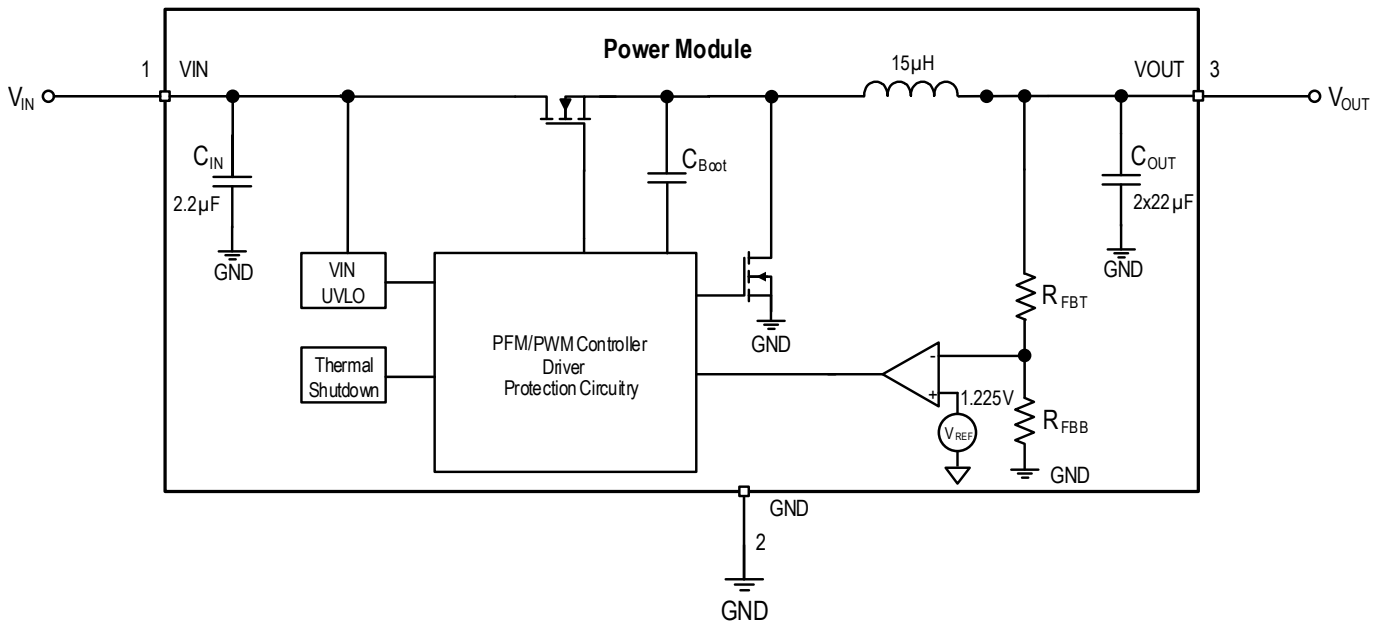

Figure 8: Block diagram.

14 CIRCUIT DESCRIPTION

The MagI³C power module 173951275 is based on a synchronous step-down regulator with integrated IC, power inductor, input and output capacitors. The control scheme is based on a constant on-time (COT) regulation loop.

The V_{OUT} of the regulator is divided by the internal feedback resistor network and fed into the error amplifier, which compares this signal with the internal 1.225V reference. The error amplifier controls the on-time of a fixed frequency pulse width generator, which drives the MOSFET.

To achieve a regulated output voltage the off-time is modulated. It is stable with low ESR output capacitors. No external compensation network is required. This architecture supports fast transient response and very small output voltage ripple values (<50mV_{pp}) are achieved.

15 OUTPUT VOLTAGE RIPPLE

The output voltage ripple depends on several parameters. The figure below shows the V_{OUT} ripple at full load using no external output capacitor. An output voltage ripple of less than 80mV_{pp} is measured under the conditions indicated. To reduce the output ripple further it is recommended to add two $22\mu\text{F}$ MLCC output capacitors.

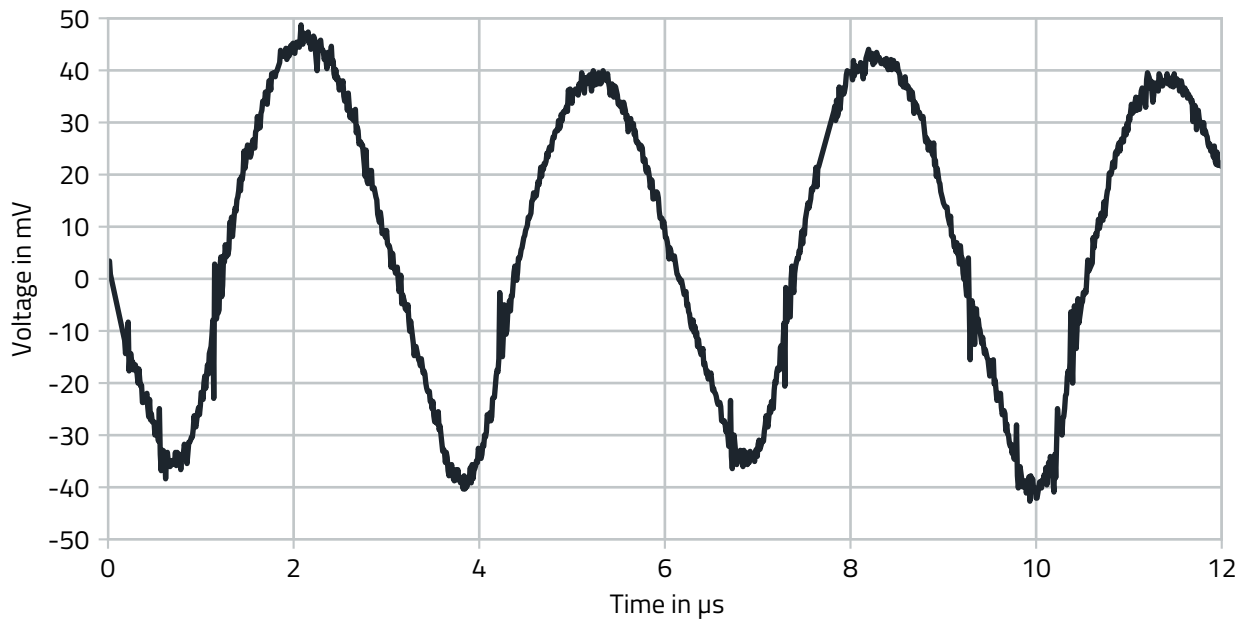

Figure 9: Output voltage ripple.

16 PROTECTION FEATURES

16.1 Soft-Start

An approximately 2ms internal soft-start prevents the output voltage from overshooting during start up.

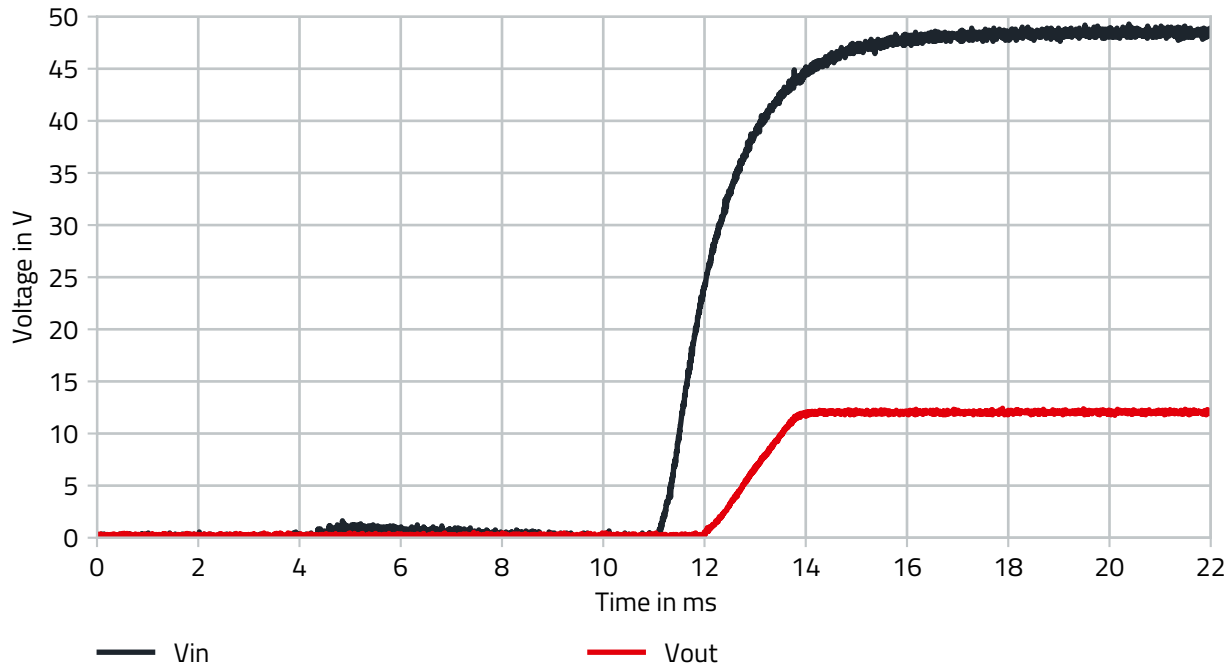

Figure 10: Soft-start.

16.2 Over Temperature Protection (OTP)

Thermal protection helps to prevent catastrophic failures due to accidental device overheating. The junction temperature of the MagI³C power module should not be allowed to exceed its maximum ratings. Thermal protection is implemented by an internal thermal shutdown circuit, which activates when the junction temperature reaches 165°C (typ.), causing the device to enter a low power standby state. Under the thermal shutdown condition both MOSFETs remain off, causing the output voltage to drop. When the junction temperature falls below 145°C (typ.) the internal soft-start is released, V_{OUT} rises smoothly, and normal operation resumes.

16.3 Short Circuit Protection (SCP)

The short circuit protection is realized via cycle-by-cycle "valley" mechanism, measuring the inductor current through the synchronous rectifier during the off-time while the inductor current ramps down. If the current exceeds the current limit, the turn-on signal of top MOSFET is inhibited and the output voltage drops until the inductor current ramps down below the current limit. If the short condition is still present after a few hundred microseconds, the regulator enters hiccup mode. This process of start-up and hiccup iterate itself until the short condition is removed.

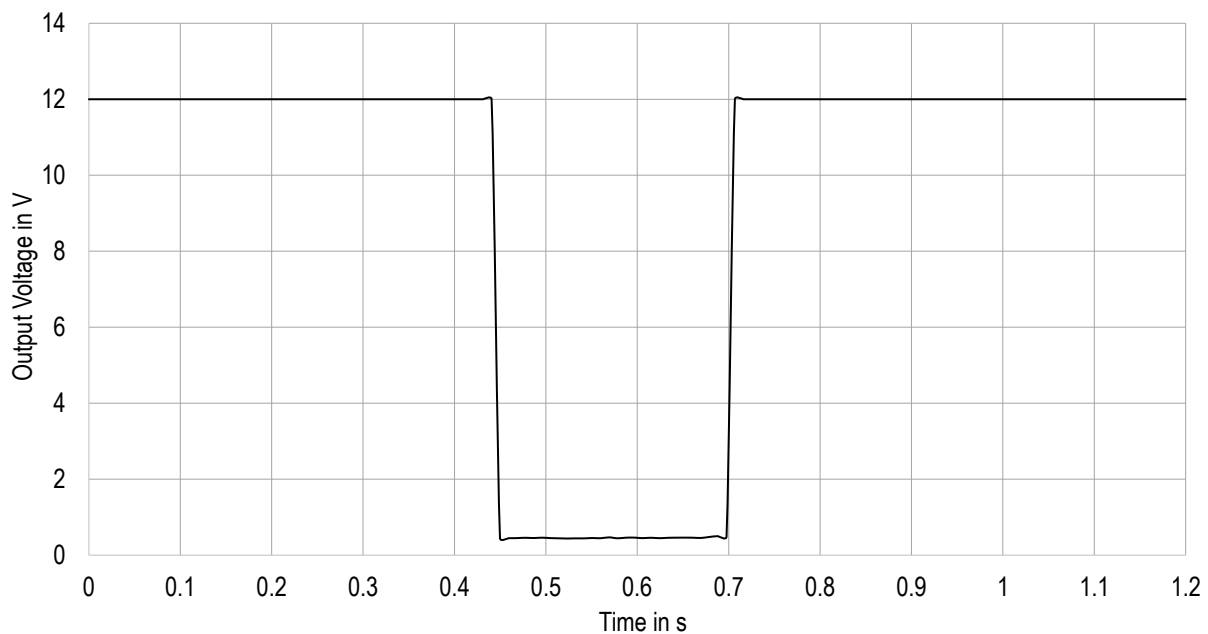

Figure 11: Short circuit protection.

16.4 Over Current Protection (OCP)

For protection against load faults, the power module incorporates cycle by cycle current monitoring. During an over current condition the output current is limited and the output voltage drops. When the overcurrent condition is removed, the output voltage returns to the nominal voltage.

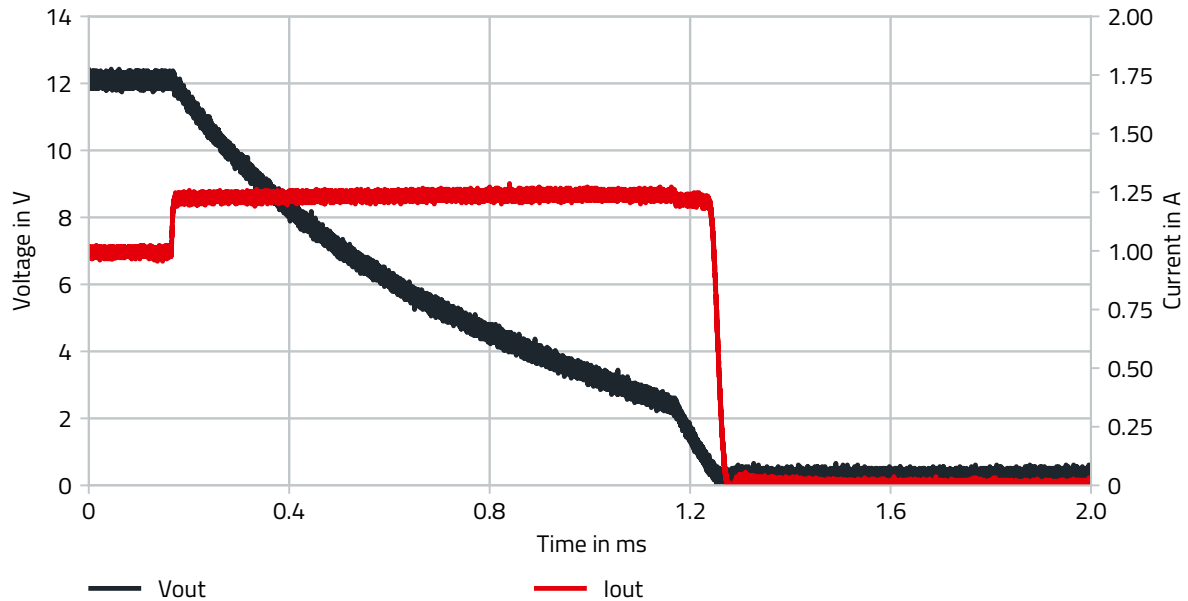

Figure 12: Over current protection.

17 DESIGN EXAMPLE

The design example shows a possible solution for 48V to 12V with a max lout of 0.5A. All of the necessary components to fulfill the requirements of the CISPR-32 EMI conducted and radiated emissions tests are included in the design example. It passes the conducted emissions class B with 0.8m input and 1m output lines and passes the radiated emissions class B in a FAR at 3m measurement distance with 0.8m horizontal, 0.8m vertical input and 1m horizontal output lines. Filter components may be omitted depending on the requirements of the final application.

17.1 Layout

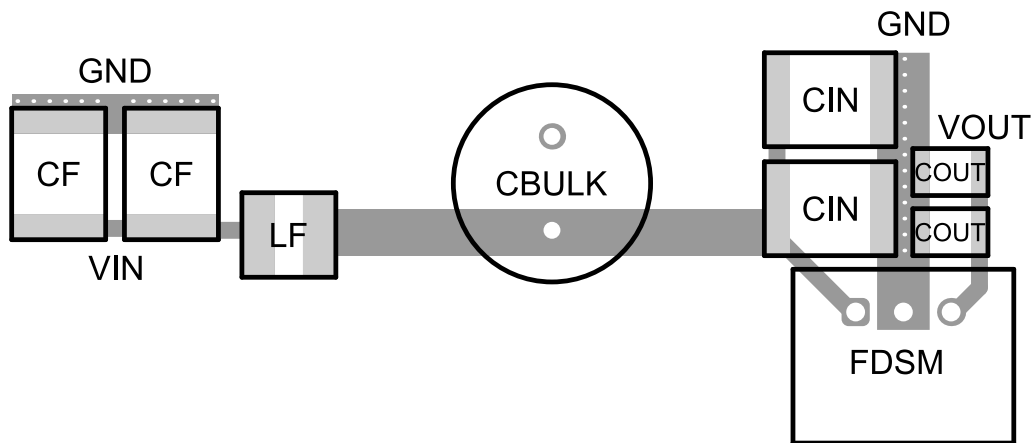

Figure 13: Layout recommendation.

The layout above has been evaluated to provide the optimal performance in terms of transient response, efficiency, ripple and EMI. The design footprint can be reduced at the expense of performance in these parameters.

The following recommendation should be followed when designing the layout:

1. The input and output capacitors should be placed as close as possible to the module pins.
2. The bulk capacitor should be placed close to the input capacitors of the module.
3. To avoid direct coupling of the DC-DC converter's E- and H-fields into connectors, filter components and cables, the module must be placed as far away from these components as possible.

17.2 Schematic

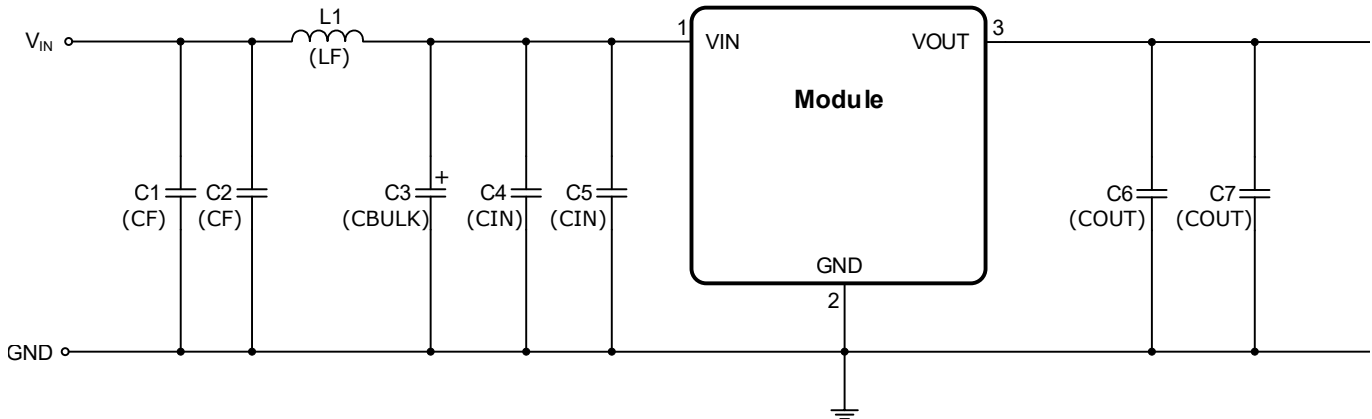

Figure 14: Design example schematic.

17.3 Bill of Materials

Table 11: Design example bill of materials.

DESIGNATOR	DESCRIPTION	FUNCTION	QUANTITY	ORDER CODE	MANUFACTURER
U1	Magi ³ C Power Module	Power supply	1	173951275	WE
L1	Filter inductor, 4.7μH, PD2 family, I _{SAT} = 2.46A, I _R = 1.82A	Input Filter	1	744773047	WE
C1, C2	Ceramic chip capacitor 10μF/100V X7R, 2220	Input Filter	2	885012214006	WE
C3	Aluminum electrolytic capacitor 100μF/100V	Input Filter	1	860040875005	WE
C4, C5	Ceramic chip capacitor 10μF/100V X7R, 2220	Input Filter / Electrical Performance	2	885012214006	WE
C6, C7	Ceramic chip capacitor 22μF/25V X7R, 1210	Output Filter / Electrical Performance	2	885012209074	WE

18 OUTPUT VOLTAGE FEATURES

A common requirement in industrial applications is to provide multiple supply voltages (e.g. 3.3V / 5V / 12V). The circuit below shows how this can be achieved by connecting the required members of the FDSM family in parallel, all with the same source. The use of two 22 μ F MLCCs at the output of each module is recommended to keep the output voltage ripple low. When using multiple modules connected to a single DC bus voltage it is recommended to decouple the individual module inputs by using LC filters. An LC filter at the input reduces the likelihood of oscillations due to parasitics of the layout as well as to prevent the input ripple of the modules from affecting each other. The recommended EMI filter (see [DESIGN EXAMPLE](#)) offers a starting point for the decoupling filter design. Further evaluation of the filter and module within the application system is necessary to determine the best component values for optimal performance.

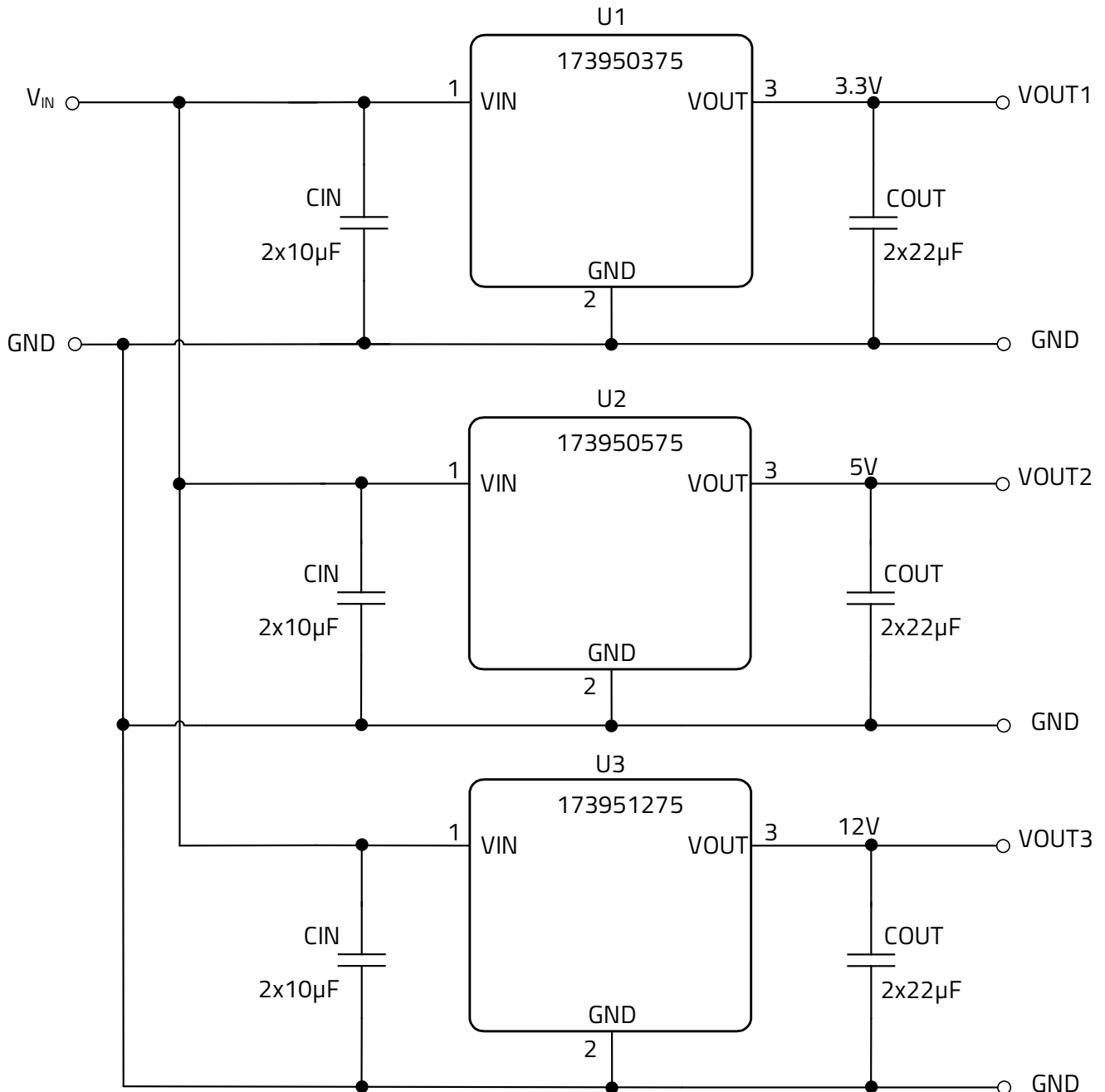

Figure 15: Multiple output voltage schematic.

19 HANDLING RECOMMENDATIONS

1. According to JEDEC J-STD033 an MSL classification is not applicable for THT components. Therefore the power module does not require special handling or storage to protect it from ambient moisture.
2. The profile below is valid for wave soldering only.

19.1 Soldering Profile

Table 12: Wave solder profile.

Profile Feature	Old standard (Pb)	New (Pb-free)
Time within peak temperature t_p	max. 10s max. 5s each wave	max. 10s max. 5s each wave
Average ramp-up rate	200°C/s	200°C/s
Final preheat temperature T_s	130°C/s	130°C/s
Peak temperature T_p	+235°C/s	+260°C/s
Ramp-down rate	-5°C/s	-5°C/s
Heating rate during preheat	4°C/s	4°C/s

Wave Solder Diagram:

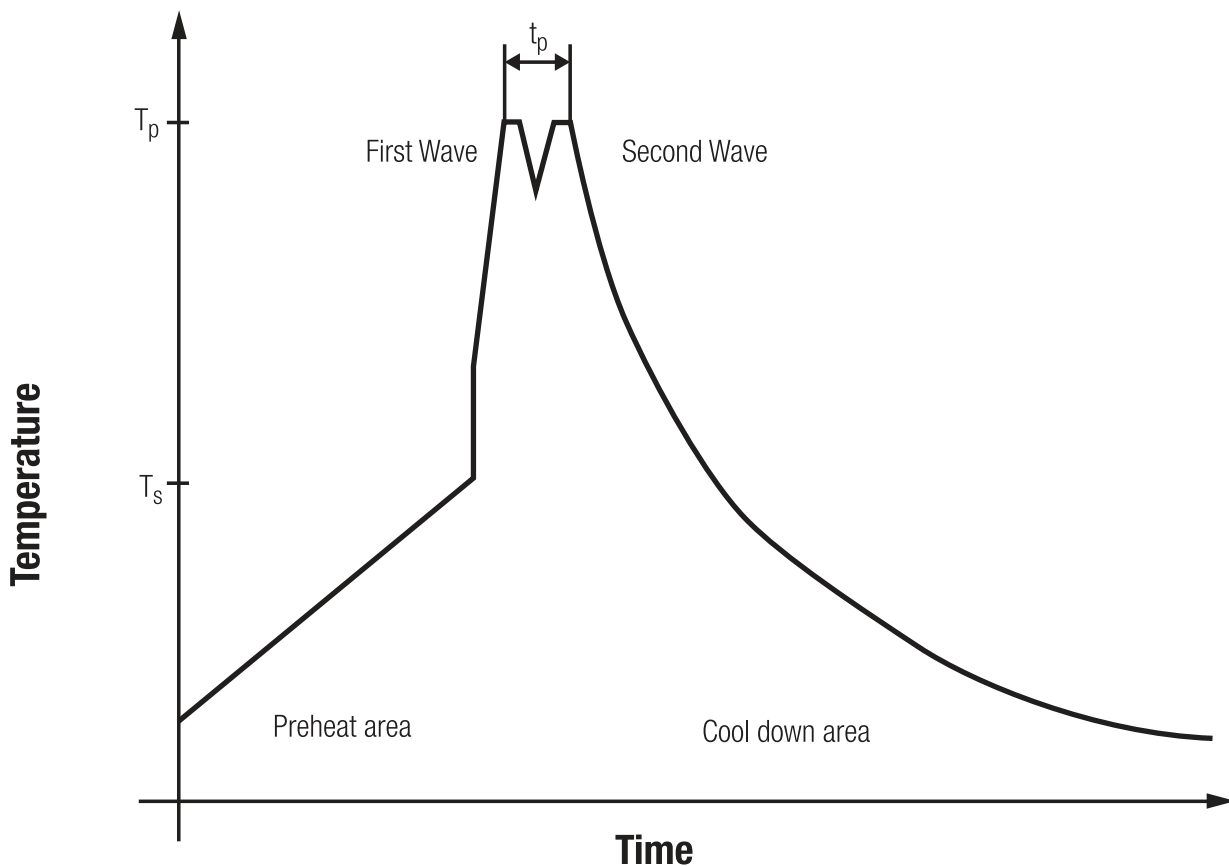

Figure 16: Solder profile.

Manual Soldering

1. Maximum soldering temperature should not exceed 365°C ±15°C.
2. Maximum soldering time: max. 3 seconds.

20 PHYSICAL DIMENSIONS

20.1 Component

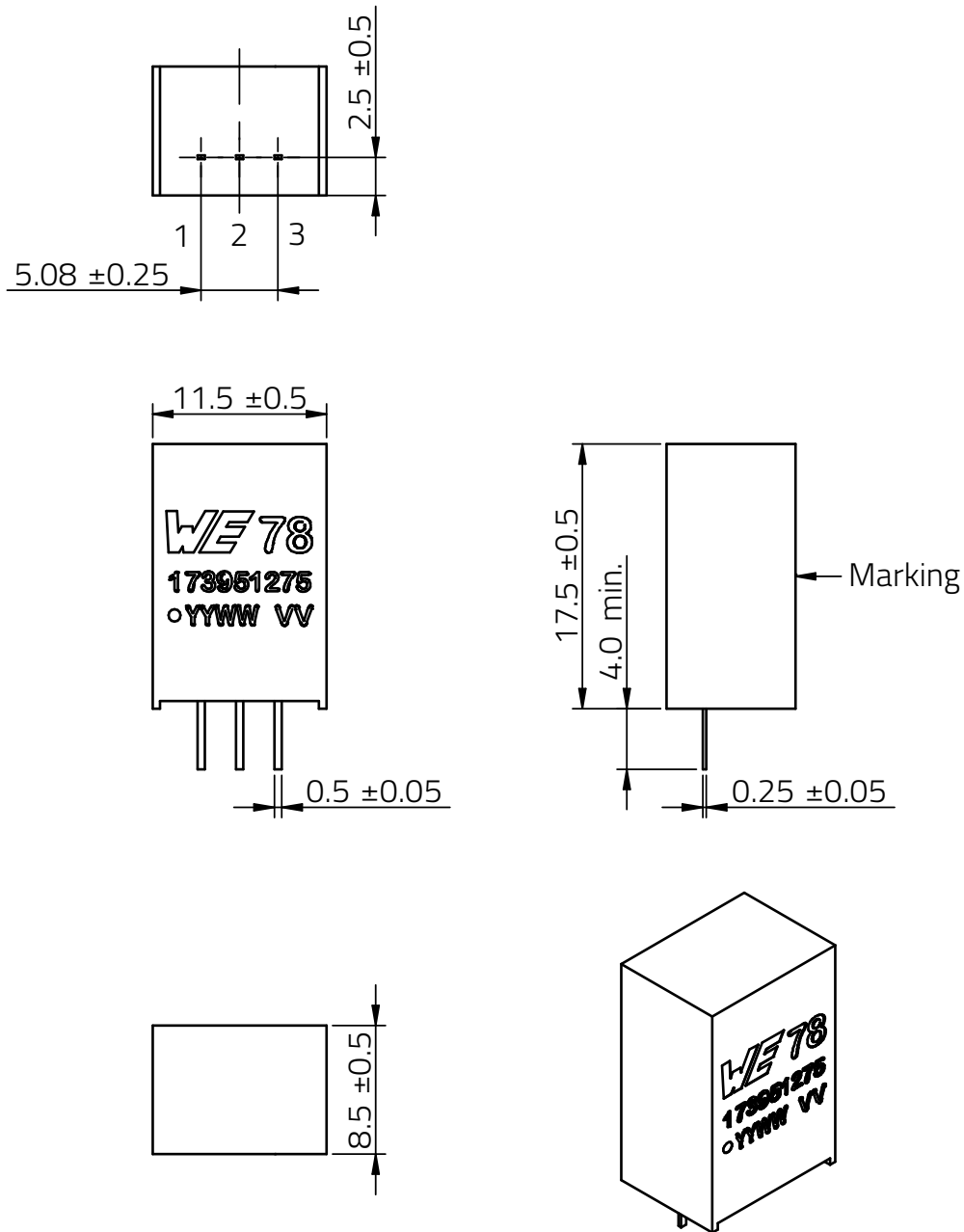

Figure 17: Physical dimensions.

20.2 Recommended Drill Holes

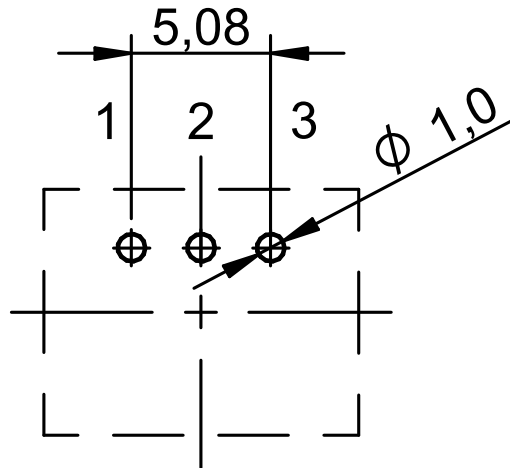

Figure 18: Recommended drill holes.

20.3 Tube

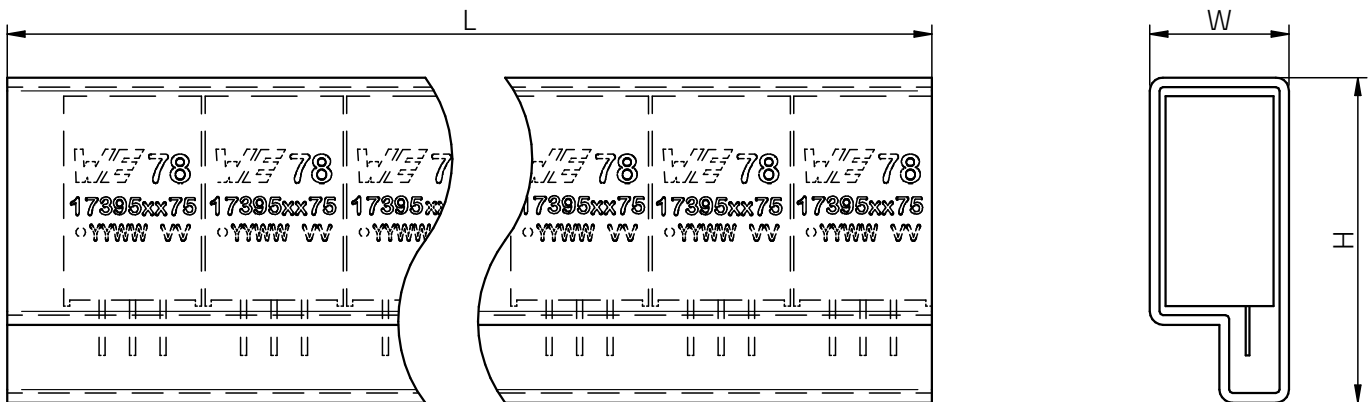

Figure 19: Tube.

Table 13: Packaging dimensions.

Dimension	L	W	H
Tolerance	typ.	typ.	typ.
Value	520mm	18.90mm	23.80mm

21 DOCUMENT HISTORY

Table 14: Document history.

Revision	Date	Description	Comment
1.0	November 2021	Initial data sheet release	
1.1	January 2022	Minor Change	Added pin position
1.2	July 2023	Minor Change	To improve the EMI performance the EMI filter as well as the input capacitors recommendation was changed. For further noise damping the bulk capacitor CBULK has been added to the filter recommendation. Updated data sheet to the latest format.
2.0	January 2025	PCN Major Change	Due to an improvement of the production capability, Würth Elektronik eiSos has shifted the production of the affected part number to a new factory location. With the aim of an extended product applicability, Würth Elektronik eiSos has updated the BOM used in the module to ensure the best performance and the electrical specifications.

22 LIST OF FIGURES

1	Pinout.	4
2	Radiated EMI with input filter.	10
3	Conducted EMI with input filter.	10
4	Efficiency.	11
5	Thermal derating.	11
6	Load regulation.	12
7	Line regulation.	12
8	Block diagram.	13
9	Output voltage ripple.	14
10	Soft-start.	15
11	Short circuit protection.	16
12	Over current protection.	17
13	Layout recommendation.	18
14	Design example schematic.	19
15	Multiple output voltage schematic.	20
16	Solder profile.	21
17	Physical dimensions.	22
18	Recommended drill holes.	23
19	Tube.	23



23 LIST OF TABLES

1	Marking description.	4
2	Pin description.	4
3	Pinout compatible family members.	5
4	Sales information.	5
5	Absolute maximum ratings.	6
6	Operating conditions.	6
7	Electrical specifications.	7
8	RoHS, REACH.	8
9	Reliability.	8
10	Package specifications.	8
11	Design example bill of materials.	19
12	Wave solder profile.	21
13	Packaging dimensions.	23
14	Document history.	24

24 CAUTIONS AND WARNINGS

The following conditions apply to all goods within the product series of MagI³C of Würth Elektronik eiSos GmbH & Co. KG:

General:

- All recommendations according to the general technical specifications of the data-sheet have to be complied with.
- The usage and operation of the product within ambient conditions which probably alloy or harm the component surface has to be avoided.
- The responsibility for the applicability of customer specific products and use in a particular customer design is always within the authority of the customer. All technical specifications for standard products do also apply for customer specific products
- Residual washing varnish agent that is used during the production to clean the application might change the characteristics of the body, pins or termination. The washing varnish agent could have a negative effect on the long term function of the product. Direct mechanical impact to the product shall be prevented as the material of the body, pins or termination could flake or in the worst case it could break. As these devices are sensitive to electrostatic discharge customer shall follow proper IC Handling Procedures.
- Customer acknowledges and agrees that it is solely responsible for compliance with all legal, regulatory and safety-related requirements concerning its products, and any use of Würth Elektronik eiSos GmbH & Co. KG components in its applications, notwithstanding any applications-related information or support that may be provided by Würth Elektronik eiSos GmbH & Co. KG.
- Customer represents and agrees that it has all the necessary expertise to create and implement safeguards which anticipate dangerous consequences of failures, monitor failures and their consequences lessen the likelihood of failures that might cause harm and take appropriate remedial actions
- Customer will fully indemnify Würth Elektronik eiSos and its representatives against any damages arising out of the use of any Würth Elektronik eiSos GmbH & Co. KG components in safety-critical applications

Product specific:

Follow all instructions mentioned in the datasheet, especially:

- The solder profile has to comply with the technical reflow or wave soldering specification, otherwise this will void the warranty.
- All products are supposed to be used before the end of the period of 12 months based on the product date-code.
- Violation of the technical product specifications such as exceeding the absolute maximum ratings will void the warranty.
- It is also recommended to return the body to the original moisture proof bag and reseal the moisture proof bag again.
- ESD prevention methods need to be followed for manual handling and processing by machinery.

Disclaimer:

This electronic component has been designed and developed for usage in general electronic equipment only. This product is not authorized for use in equipment where a higher safety standard and reliability standard is especially required or where a failure of the product is reasonably expected to cause severe personal injury or death, unless the parties have executed an agreement specifically governing such use. Moreover Würth Elektronik eiSos GmbH & Co. KG products are neither designed nor intended for use in areas such as military, aerospace, aviation, nuclear control, submarine, transportation (automotive control, train control, ship control), transportation signal, disaster prevention, medical, public information network etc. Würth Elektronik eiSos GmbH & Co. KG must be informed about the intent of such usage before the design-in stage. In addition, sufficient reliability evaluation checks for safety must be performed on every electronic component which is used in electrical circuits that require high safety and reliability functions or performance. These cautions and warnings comply with the state of the scientific and technical knowledge and are believed to be accurate and reliable. However, no responsibility is assumed for inaccuracies or incompleteness.

25 IMPORTANT NOTES

General Customer Responsibility

Some goods within the product range of Würth Elektronik eiSos GmbH & Co. KG contain statements regarding general suitability for certain application areas. These statements about suitability are based on our knowledge and experience of typical requirements concerning the areas, serve as general guidance and cannot be estimated as binding statements about the suitability for a customer application. The responsibility for the applicability and use in a particular customer design is always solely within the authority of the customer. Due to this fact it is up to the customer to evaluate, where appropriate to investigate and decide whether the device with the specific product characteristics described in the product specification is valid and suitable for the respective customer application or not. Accordingly, the customer is cautioned to verify that the datasheet is current before placing orders.

Customer Responsibility Related to Specific, in Particular Safety-Relevant, Applications

It has to be clearly pointed out that the possibility of a malfunction of electronic components or failure before the end of the usual lifetime cannot be completely eliminated in the current state of the art, even if the products are operated within the range of the specifications. In certain customer applications requiring a very high level of safety and especially in customer applications in which the malfunction or failure of an electronic component could endanger human life or health it must be ensured by most advanced technological aid of suitable design of the customer application that no injury or damage is caused to third parties in the event of malfunction or failure of an electronic component.

Best Care and Attention

Any product-specific notes, warnings and cautions must be strictly observed. Any disregard will result in the loss of warranty.

Customer Support for Product Specifications

Some products within the product range may contain substances which are subject to restrictions in certain jurisdictions in order to serve specific technical requirements. Necessary information is available on request. In this case the field sales engineer or the internal sales person in charge should be contacted who will be happy to support in this matter.

Product R&D

Due to constant product improvement product specifications may change from time to time. As a standard reporting procedure of the Product Change Notification (PCN) according to the JEDEC-Standard we inform about minor and major changes. In case of further queries regarding the PCN, the field sales engineer or the internal sales person in charge should be contacted. The basic responsibility of the customer as per Section 1 and 2 remains unaffected.

Product Life Cycle

Due to technical progress and economical evaluation we also reserve the right to discontinue production and delivery of products. As a standard reporting procedure of the Product Termination Notification (PTN) according to the JEDEC Standard we will inform at an early stage about inevitable product discontinuance. According to this we cannot guarantee that all products within our product range will always be available. Therefore it needs to be verified with the field sales engineer or the internal sales person in charge about the current product availability expectancy before or when the product for application design-in disposal is considered. The approach named above does not apply in the case of individual agreements deviating from the foregoing for customer-specific products.

Property Rights

All the rights for contractual products produced by Würth Elektronik eiSos GmbH & Co. KG on the basis of ideas, development contracts as well as models or templates that are subject to copyright, patent or commercial protection supplied to the customer will remain with Würth Elektronik eiSos GmbH & Co. KG. Würth Elektronik eiSos GmbH & Co. KG does not warrant or represent that any license, either expressed or implied, is granted under any patent right, copyright, mask work right, or other intellectual property right relating to any combination, application, or process in which Würth Elektronik eiSos GmbH & Co. KG components or services are used.

General Terms and Conditions

Unless otherwise agreed in individual contracts, all orders are subject to the current version of the "General Terms and Conditions of Würth Elektronik eiSos Group", last version available at www.we-online.com.