

Overview

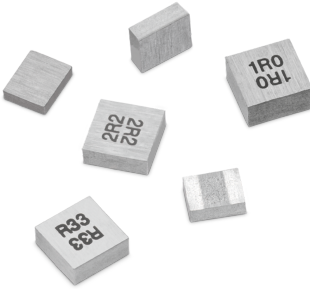

Characteristics

- Magnetic iron alloy allows high rated currents
- Compact design
- Magnetically shielded
- No acoustic noise and no leakage flux noise
- Operating temperature range: -40 °C up to +125 °C (HT: -55 °C up to +150 °C)
- AEC-Q200

Applications

- Powertrain converters
- Body electronics & lighting
- Infotainment systems
- DC/DC-converter 48 V/12 V
- POL-converters
- DC/DC-converter for field programmable gate array
- BMS (battery management system)

Schematic:

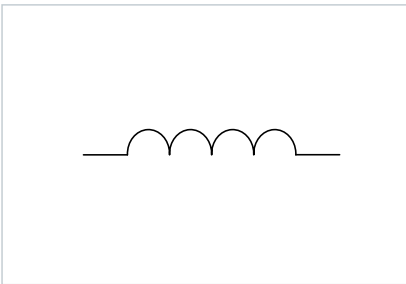

Certification:	
RoHS Approval	Compliant [2011/65/EU&2015/863]
REACH Approval	Conform or declared [(EC)1907/2006]
Halogen Free	Conform [JEDEC JS709B]
Halogen Free	Conform [IEC 61249-2-21]
Automotive Approval	Released
Component Qualification	AEC-Q200 Grade 1

General Properties:	
Ambient Temperature	-40 °C up to +85 °C
Operating Temperature	-40 °C up to +125 °C
Storage Conditions (in original packaging)	< 40 °C ; < 75 % RH
Moisture Sensitivity Level (MSL)	1
Test conditions of Electrical Properties: +20 °C, 33 % RH if not specified differently	
Test conditions of Rated Current: refer to IEC 62024-2-2020, Class C (PCB Copper Width: 40 mm; PCB Copper Thickness: 105 µm)	

ORDER
SAMPLES

SIMULATE IN
REDEXPERT



Specific Information

Order Code	L (μ H)	$I_{R,40K}$ (A)	$I_{SAT,10\%}$ (A)	$I_{SAT,30\%}$ (A)	$R_{DC,max.}$ (m Ω)	f_{res} (MHz)	Mount	Revision
Size 1610								
784383130033	0.33	3.25	3.35	6.2	84	215	SMT	002.000
784383130047	0.47	2.95	3.05	5.6	101	200	SMT	002.000
784383130056	0.56	2.7	2.75	5.2	113	150	SMT	002.000
784383130068	0.68	2.55	2.55	4.8	126	135	SMT	002.000
784383130082	0.82	2.35	2.5	4.6	144	115	SMT	002.000
78438313010	1	2.2	2.25	4.25	159	111	SMT	002.000
78438313012	1.2	2.1	2.2	4.1	174	109	SMT	002.000
78438313015	1.5	1.8	1.8	3.45	237	90	SMT	002.000
78438313022	2.2	1.25	1.5	3.25	388	70	SMT	002.000
Size 2506								
784383210047	0.47	3.25	2.55	4.65	95	165	SMT	003.000
78438321010	1	2.1	1.7	3.25	196	90	SMT	003.000
Size 2508								
784383220047	0.47	3.35	2.85	5.65	87	160	SMT	003.000
78438322010	1	2.65	2.15	4.4	133	100	SMT	003.000
78438322022	2.2	1.65	1.4	2.8	302	60	SMT	003.000
Size 2510								
784383230033	0.33	5.5	4.25	8	38	180	SMT	003.000
784383230047	0.47	4.8	3.6	6.9	48	170	SMT	003.000
784383230068	0.68	4.25	3.1	6.1	60	135	SMT	003.000
784383230082	0.82	3.9	2.7	5.45	69	105	SMT	003.000
78438323010	1	3.55	2.6	5.3	75	80	SMT	003.000
78438323012	1.2	3.05	2.45	4.85	106	75	SMT	003.000
78438323015	1.5	2.85	2.25	4.75	110	65	SMT	003.000
78438323022	2.2	2.2	2	3.55	176	60	SMT	003.000
78438323033	3.3	1.75	1.35	2.7	264	50	SMT	003.000
78438323047	4.7	1.4	1.1	2.3	388	35	SMT	003.000
78438323068	6.8	1.05	1.05	2	648	30	SMT	003.000
78438323082	8.2	0.95	0.9	1.85	743	27	SMT	003.000
78438323100	10	0.9	0.85	1.7	843	25	SMT	003.000
Size 2512								
784383240047	0.47	5.35	4.15	8	40	145	SMT	004.000
784383240056	0.56	4.75	4.25	7.9	49	120	SMT	004.000
784383240068	0.68	4.25	3.8	7.4	59	102	SMT	004.000
78438324010	1	4.05	3.2	6.3	60	85	SMT	004.000
78438324012	1.2	3.4	3.05	5.8	80	80	SMT	004.000
78438324015	1.5	3.05	2.5	4.7	99	60	SMT	004.000
78438324022	2.2	2.45	1.85	3.65	141	57	SMT	004.000
78438324033	3.3	1.7	1.75	3.3	260	42	SMT	004.000
78438324047	4.7	1.45	1.4	2.65	345	35	SMT	004.000
78438324056	5.6	1.25	1.15	2.2	465	30	SMT	004.000
78438324068	6.8	1.05	1	2.05	640	27	SMT	004.000

**ORDER
SAMPLES**
**SIMULATE IN
REDEXPERT**

Specific Information

Order Code	L (μ H)	$I_{R,40K}$ (A)	$I_{SAT,10\%}$ (A)	$I_{SAT,30\%}$ (A)	$R_{DC,max.}$ (m Ω)	f_{res} (MHz)	Mount	Revision
78438324082	8.2	0.95	1	1.9	720	25	SMT	004.000
78438324100	10	0.9	0.95	1.75	780	23	SMT	004.000
Size 3010								
78438333022	2.2	2.35	2.75	4.85	172	50	SMT	003.000
78438333033	3.3	1.85	2.05	3.7	266	38	SMT	003.000
78438333047	4.7	1.45	1.65	3	409	35	SMT	003.000
Size 3012								
784383340033	0.33	7.4	8.1	13.3	22.8	140	SMT	003.000
784383340047	0.47	6.8	5.95	12.3	26.4	110	SMT	003.000
784383340056	0.56	5.8	5.65	11.1	34.8	108	SMT	003.000
784383340068	0.68	5.15	4.95	10	43.2	100	SMT	003.000
78438334010	1	4.75	4.3	8.4	50.5	80	SMT	003.000
78438334012	1.2	4.05	4.15	7.5	66	66	SMT	003.000
78438334015	1.5	3.3	3.9	7.1	96	60	SMT	003.000
78438334022	2.2	2.9	3.6	6.1	115	50	SMT	003.000
78438334033	3.3	2.25	2.75	5.1	179.7	36	SMT	003.000
78438334047	4.7	1.7	2.6	4.75	307.8	30	SMT	003.000
78438334056	5.6	1.45	2.1	3.7	389	28	SMT	003.000
78438334068	6.8	1.4	1.75	3.5	423.4	25	SMT	003.000
Size 3015								
784383350047	0.47	7.1	4.35	7.4	23	105	SMT	003.000
784383350068	0.68	6.3	5.8	9.7	30	100	SMT	003.000
784383350082	0.82	5.7	4.95	9	35	85	SMT	003.000
78438335010	1	4.95	3	5.95	47	72	SMT	003.000
78438335022	2.2	3	2.5	4.2	108	45	SMT	003.000
78438335033	3.3	2.7	2.25	3.85	131	35	SMT	003.000
78438335047	4.7	2.4	1.85	3.7	162	30	SMT	003.000
78438335068	6.8	1.75	1.6	3.1	287	25	SMT	003.000
78438335100	10	1.25	1.35	3	513	21	SMT	003.001
78438335150	15	0.95	1.17	2.2	830	14	SMT	003.001
78438335220	22	0.85	1.1	2	1040	12	SMT	003.001
78438335330	33	0.7	0.9	1.7	1330	10	SMT	003.001
78438335470	47	0.5	0.75	1.5	2300	8	SMT	003.001
Size 3020								
784383360033	0.33	8.7	5.45	10.5	17	140	SMT	003.000
784383360047	0.47	7.55	5.4	9.8	22	99	SMT	003.000
784383360068	0.68	6.75	4.1	8.1	27	85	SMT	003.000
78438336010	1	6.15	3.25	6.5	32	67	SMT	003.000
78438336012	1.2	5.65	3.05	6	36	57	SMT	003.000
78438336015	1.5	5.35	2.95	5.85	39	51	SMT	003.000
78438336022	2.2	3.6	2.75	5.55	80	42	SMT	003.000
78438336033	3.3	2.9	2.85	5.35	114	39	SMT	003.000
78438336047	4.7	2.4	2.4	5.15	158	30	SMT	003.000

**ORDER
SAMPLES**

**SIMULATE IN
REDEXPERT**



Specific Information

Order Code	L (μ H)	$I_{R,40K}$ (A)	$I_{SAT,10\%}$ (A)	$I_{SAT,30\%}$ (A)	$R_{DC,max.}$ (m Ω)	f_{res} (MHz)	Mount	Revision
78438336068	6.8	2.15	1.85	3.65	193	22	SMT	003.000
78438336100	10	1.65	1.55	3	322	18	SMT	003.000
Size 4020								
784383560033	0.33	14.95	7.95	16.7	7.2	115	SMT	004.001
784383560056	0.56	13.65	6.9	14.7	8.4	85	SMT	004.000
784383560068	0.68	13.15	5.8	12.7	9	75	SMT	004.000
78438356010	1	10.1	5.3	11.5	15	55	SMT	004.000
78438356012	1.2	8.9	5.55	11.2	18	52	SMT	004.000
78438356015	1.5	8.6	4.8	10.2	19	48	SMT	004.000
78438356018	1.8	6.8	4.35	8.7	30	40	SMT	004.000
78438356022	2.2	6.2	4.05	7.9	35	34	SMT	004.000
78438356033	3.3	5.15	3.55	7.1	48	26	SMT	004.000
78438356047	4.7	4	3.05	5.75	76	22	SMT	004.000
78438356056	5.6	3.85	2.65	5.5	81	20	SMT	004.000
Size 4020HT								
784383560033HT	0.33	13.3	7.25	14.8	7.5	98	SMT	003.000
784383560047HT	0.47	12.7	6.45	13	8.1	83	SMT	003.000
784383560056HT	0.56	12.15	6.05	13	8.6	72	SMT	003.000
784383560068HT	0.68	11.7	5.45	11.7	9.2	67	SMT	003.000
78438356010HT	1	8.75	4.25	9.3	15.5	46	SMT	003.000
78438356012HT	1.2	8	4.3	9.3	18.4	45	SMT	003.000
78438356015HT	1.5	7.45	4.2	9	20.7	40	SMT	003.000
78438356018HT	1.8	6.05	3.95	8.3	29.9	37.5	SMT	003.000
78438356022HT	2.2	5.9	3.7	7.6	32.2	30	SMT	003.000
78438356033HT	3.3	4.45	3.1	6.5	51.8	25.5	SMT	003.000
78438356047HT	4.7	3.7	2.35	5.05	74.8	18	SMT	003.000
78438356056HT	5.6	3.5	2.25	4.9	80.5	17	SMT	003.000
Size 4030								
78438357010	1	10.25	6.2	12.5	13.5	59	SMT	003.000
78438357012	1.2	9.4	5.55	11.6	15.5	51	SMT	003.000
78438357015	1.5	8.2	5.55	11	20	48	SMT	003.000
78438357018	1.8	7.9	5.05	10.3	21	42	SMT	003.000
78438357022	2.2	7.1	4.6	9.2	26	35	SMT	003.000
78438357033	3.3	6.1	3.3	7	33.5	26	SMT	003.000
78438357047	4.7	5.1	4.15	8.2	44	24	SMT	003.000
78438357056	5.6	4.7	3.9	8.1	51	21	SMT	003.000
78438357068	6.8	3.75	3.5	7.2	74	19.5	SMT	003.000
78438357082	8.2	3.45	3.35	6.8	86	17	SMT	003.000
78438357100	10	3.05	3	5.95	110	15	SMT	003.000
Size 5020								
784383660082	0.82	13.25	7.1	15.3	9.6	53.5	SMT	002.000
78438366010	1	11.1	6.25	14	13.1	50	SMT	002.000
78438366015	1.5	8.45	5.85	13.2	21.3	35	SMT	002.000

ORDER
SAMPLES

SIMULATE IN
REDEXPERT



Specific Information

Order Code	L (μ H)	$I_{R,40K}$ (A)	$I_{SAT,10\%}$ (A)	$I_{SAT,30\%}$ (A)	$R_{DC,max.}$ (m Ω)	f_{res} (MHz)	Mount	Revision
78438366022	2.2	7.4	5.35	12	27.3	31.5	SMT	002.000
78438366033	3.3	6.1	4.4	9.7	38.4	23	SMT	002.000
78438366047	4.7	4.65	3.5	7.7	63	20	SMT	002.000
Size 5030								
78438367010	1	11.85	5.95	13.1	11.5	44.5	SMT	002.000
78438367022	2.2	9.8	4.55	10.2	16.1	28	SMT	002.000
78438367033	3.3	8	4.35	10	23	22	SMT	002.000
78438367047	4.7	6.45	3.35	6.5	34.5	18.5	SMT	002.000
78438367068	6.8	5.3	3.7	7.7	48.3	15.5	SMT	002.000
78438367082	8.2	4.85	3.25	6.6	57.5	13	SMT	002.000
78438367100	10	4.3	3.25	6.6	70.2	13	SMT	002.000

ORDER
SAMPLES

SIMULATE IN
REDEXPERT



Dimensions

Dimensions: [mm] 1610

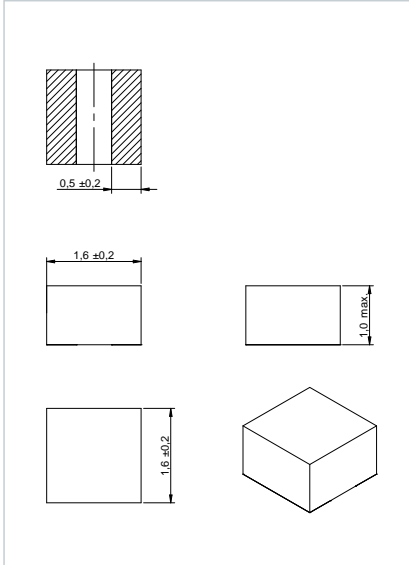

Dimensions: [mm] 2506

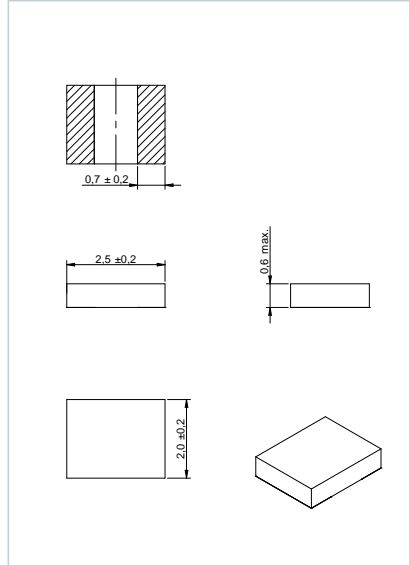

Dimensions: [mm] 2508

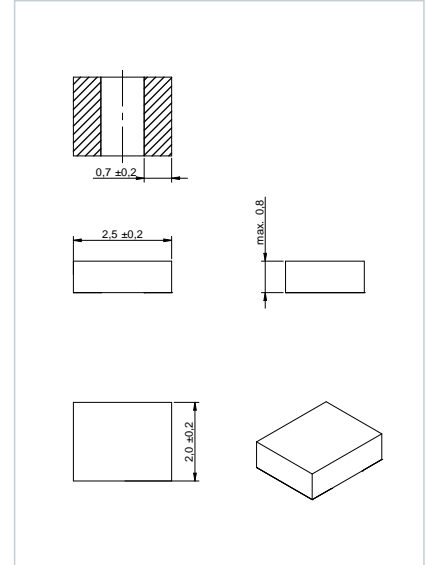

Dimensions: [mm] 2510

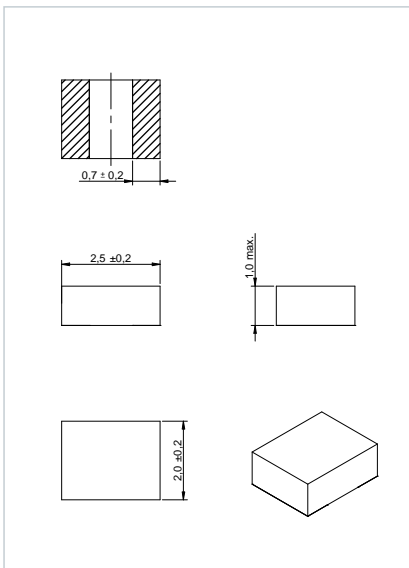

Dimensions: [mm] 2512

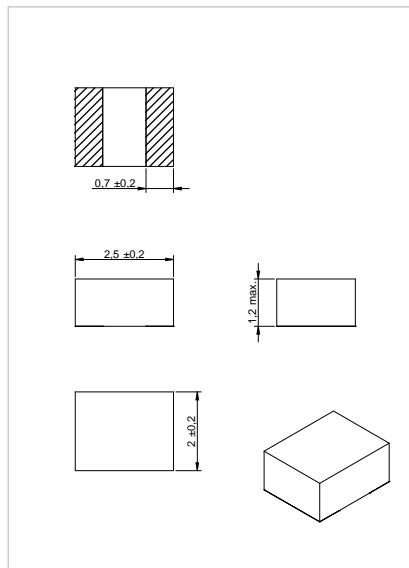

Dimensions: [mm] 3010

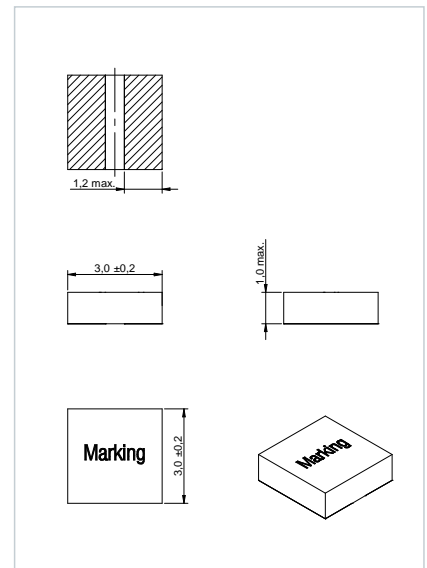

ORDER
SAMPLES

SIMULATE IN
REDEXPERT



Dimensions

Dimensions: [mm] 3012

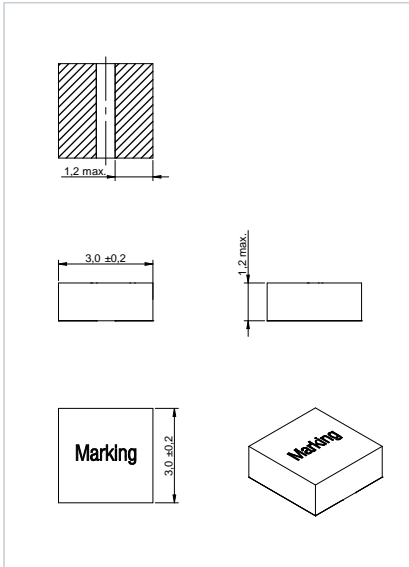

Dimensions: [mm] 3015

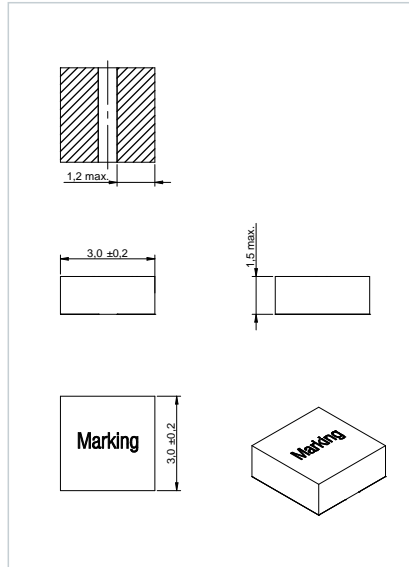

Dimensions: [mm] 3020

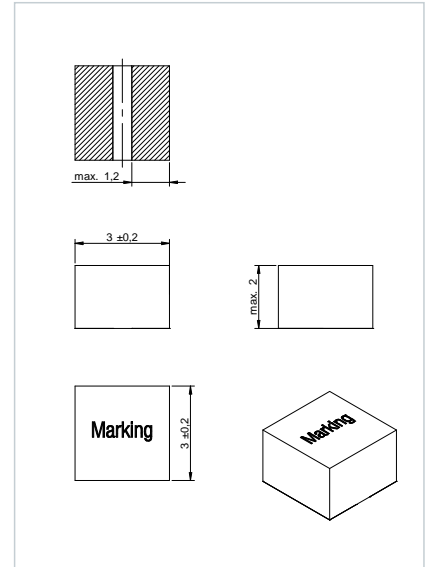

Dimensions: [mm] 4020/4020 HT

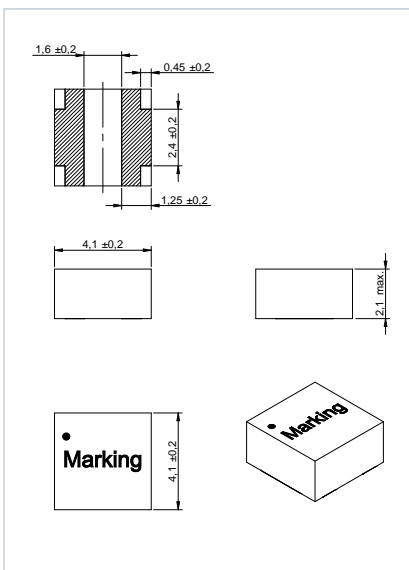

Dimensions: [mm] 4030

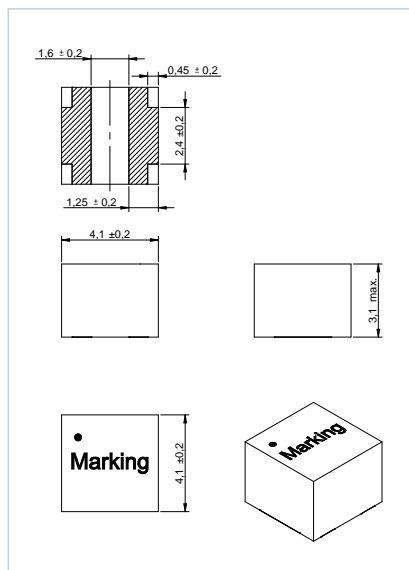

Dimensions: [mm] 5020

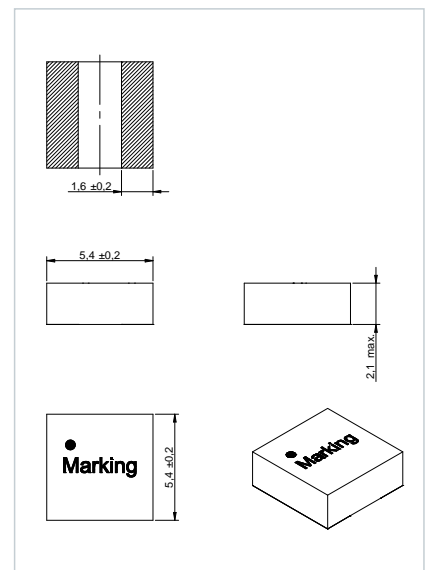

ORDER
SAMPLES

SIMULATE IN
REDEXPERT



Dimensions

Dimensions: [mm] 5030

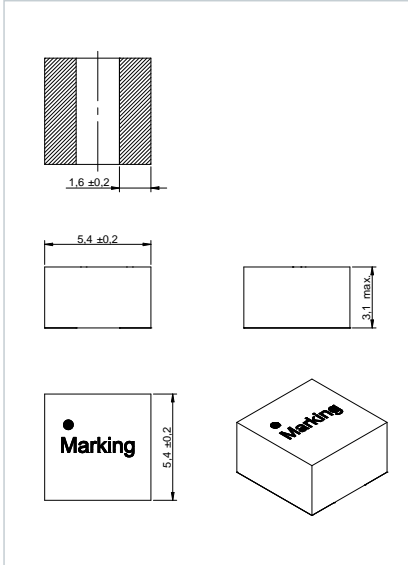

ORDER
SAMPLES

SIMULATE IN
REDEXPERT



Drawings

Recommended Land Pattern: [mm] 1610

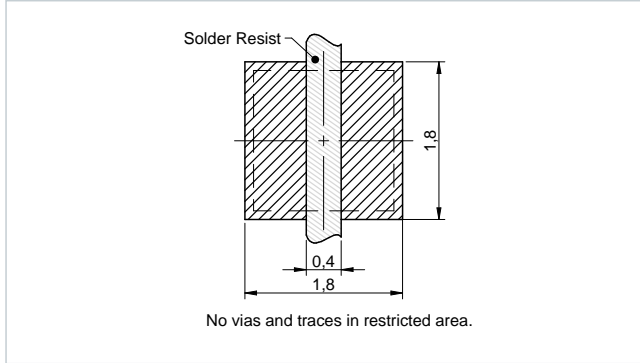

Recommended Land Pattern: [mm] 2506/2508

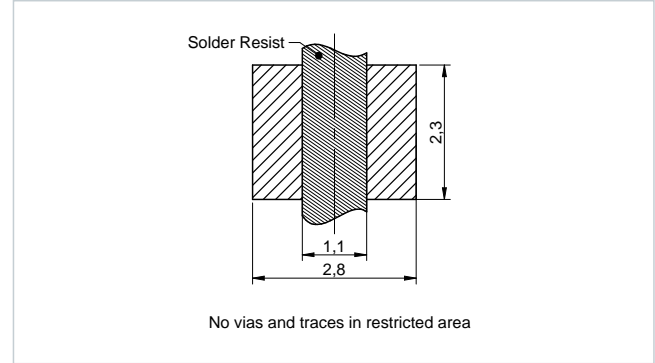

Recommended Land Pattern: [mm] 2510/2512

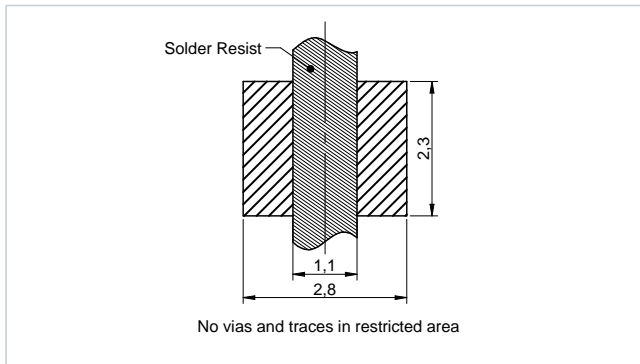

Recommended Land Pattern: [mm] 3010/3020

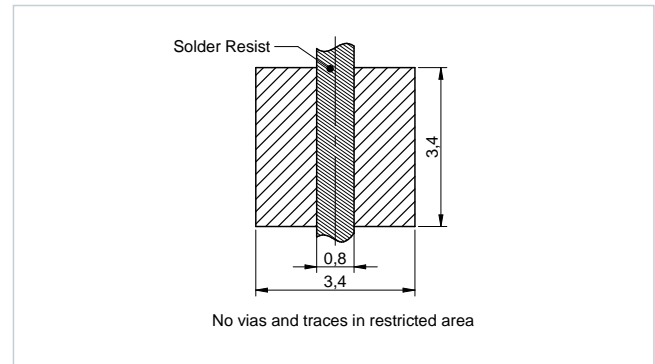

Recommended Land Pattern: [mm] 3012/3015

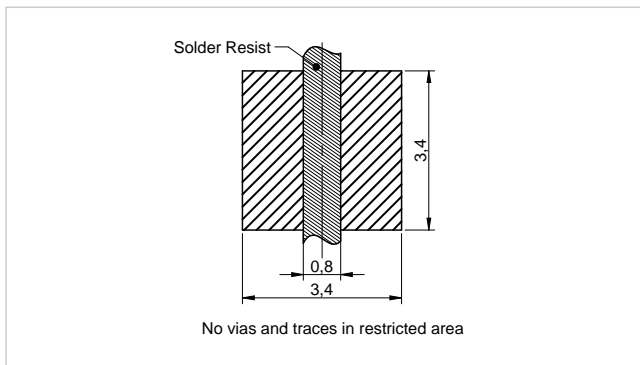

Recommended Land Pattern: [mm] 4020/4020HT

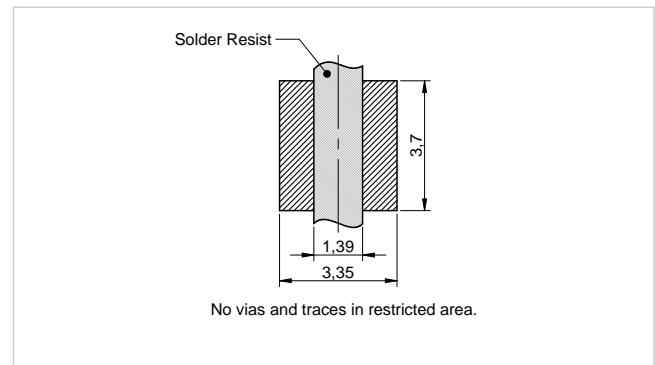

ORDER SAMPLES **SIMULATE IN REDEXPERT**



Drawings

Recommended Land Pattern: [mm] 4030

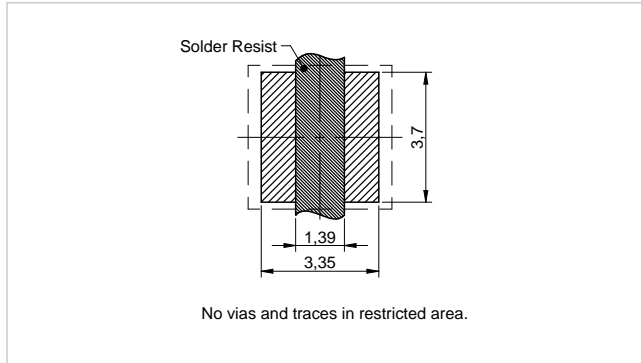

Recommended Land Pattern: [mm] 5020/5030

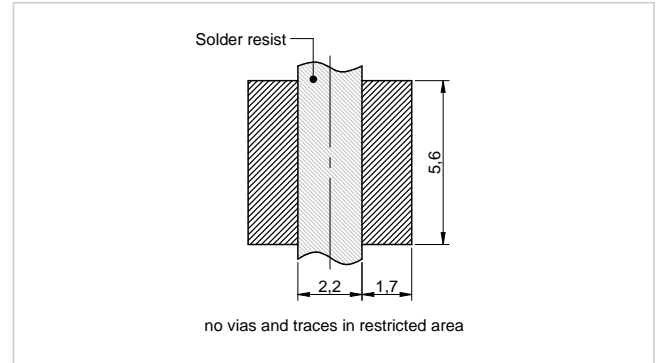

ORDER
SAMPLES

SIMULATE IN
REDEXPERT



Packaging Specification

Size 1610

Packaging Specification - Tape: [mm]

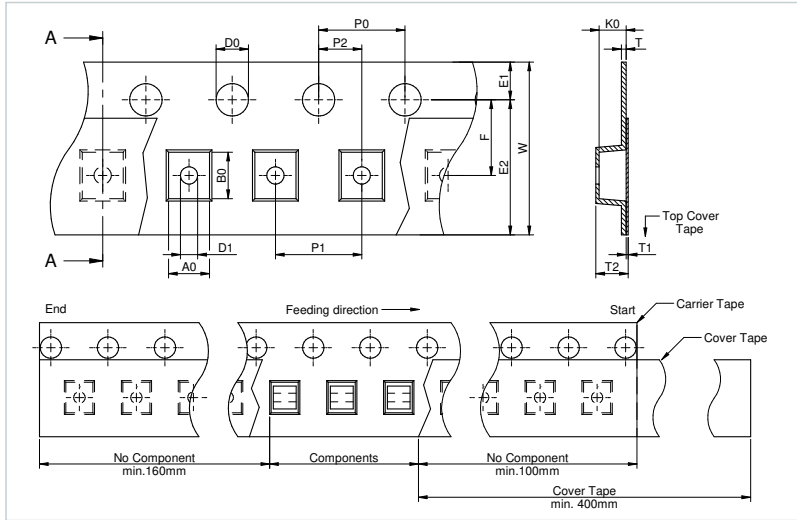

Packaging is referred to the international standard **IEC 60286-3:2019**

	Tape Type	A0 (mm)	B0 (mm)	W (mm)	T (mm)	T1 (mm)	T2 (mm)	K0 (mm)	P0 (mm)
Tolerance		typ.	typ.	+0,3/ -0,1	ref.	ref.	typ.	typ.	±0,1
Value	2a	1,90	2,15	8,00	0,22	0,10	1,15	1,15	4,00
	P1 (mm)	P2 (mm)	D0 (mm)	D1 (mm)	E1 (mm)	E2 (mm)	F (mm)	Material	Qty. (pcs.)
Tolerance	±0,1	±0,05	+0,1/ -0,0	min.	±0,1	min.	±0,05		
Value	4,00	2,00	1,50	0,30	1,75	6,25	3,50	Polystyrene	3000

Packaging Specification - Reel: [mm]

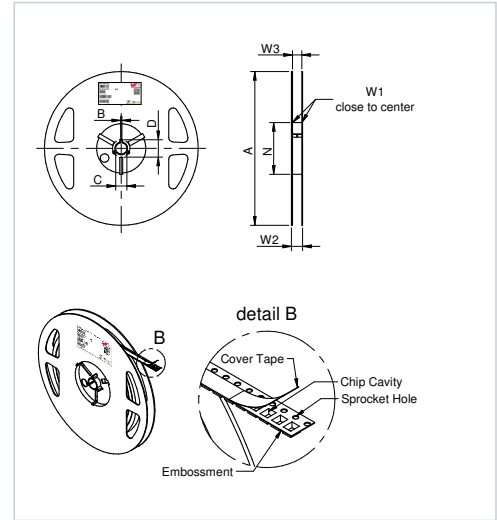

	A (mm)	B (mm)	C (mm)	D (mm)	N (mm)
Tolerance	± 2,0	min.	min.	min.	min.
Value	178	1,5	12,8	20,2	50
	W1 (mm)	W2 (mm)	W3 (mm)	W3 (mm)	Material
Tolerance	+1,5	max.	min.	max.	
Value	8,4	14,4	7,9	10,9	Polystyrene

Pull of Force:

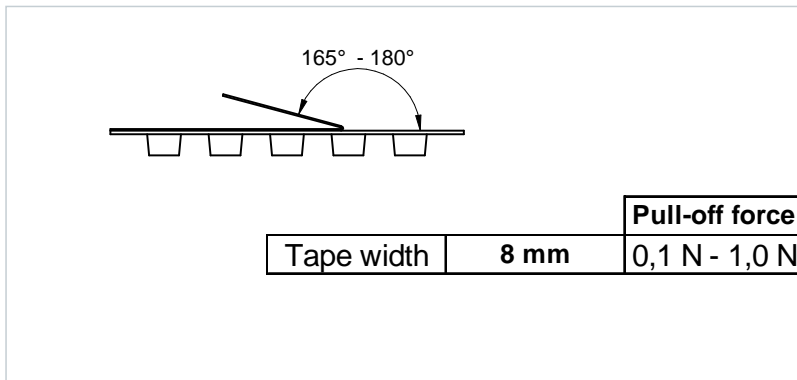

ORDER SAMPLES **SIMULATE IN REDEXPERT**



Packaging Specification

Size 2506

Packaging Specification - Tape: [mm]

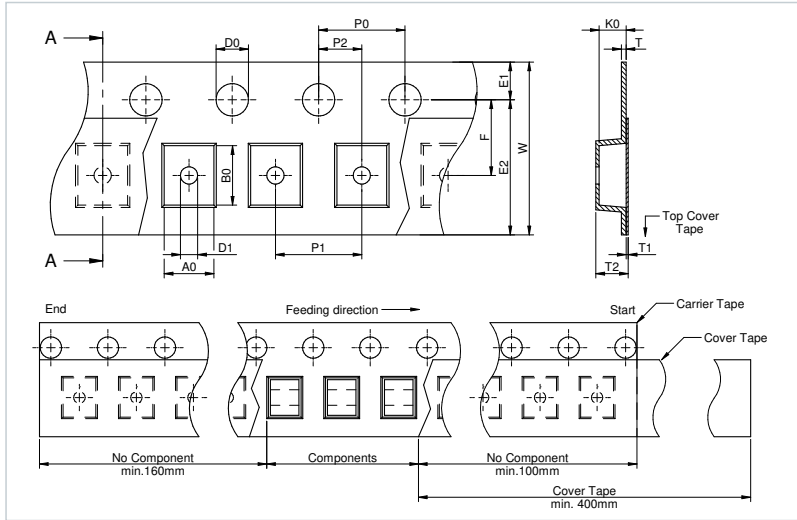

Packaging is referred to the international standard **IEC 60286-3:2019**

	Tape Type	A0 (mm)	B0 (mm)	W (mm)	T (mm)	T1 (mm)	T2 (mm)	K0 (mm)	P0 (mm)
Tolerance		typ.	typ.	+0,3/ -0,1	ref.	ref.	typ.	typ.	±0,1
Value	2a	2,30	2,75	8,00	0,22	0,10	1,80	1,17	4,00
	P1 (mm)	P2 (mm)	D0 (mm)	D1 (mm)	E1 (mm)	E2 (mm)	F (mm)	Material	Qty. (pcs.)
Tolerance	±0,1	±0,05	+0,1/ -0,0	min.	±0,1	min.	±0,05		
Value	4,00	2,00	1,50	0,30	1,75	6,25	3,50	Polystyrene	3000

Packaging Specification - Reel: [mm]

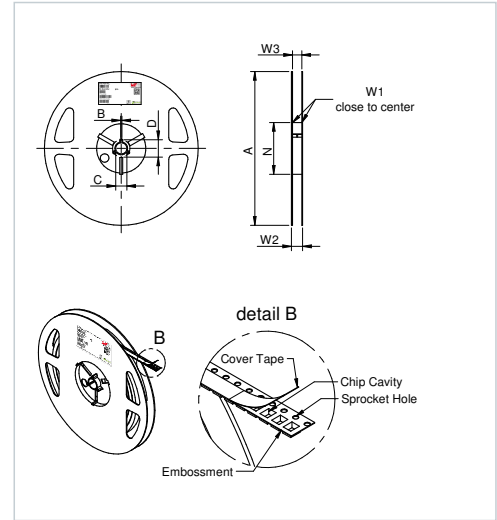

	A (mm)	B (mm)	C (mm)	D (mm)	N (mm)
Tolerance	± 2,0	min.	min.	min.	min.
Value	178	1,5	12,8	20,2	50
	W1 (mm)	W2 (mm)	W3 (mm)	W3 (mm)	Material
Tolerance	+1,5	max.	min.	max.	
Value	8,4	14,4	7,9	10,9	Polystyrene Polyurethane

Pull of Force:

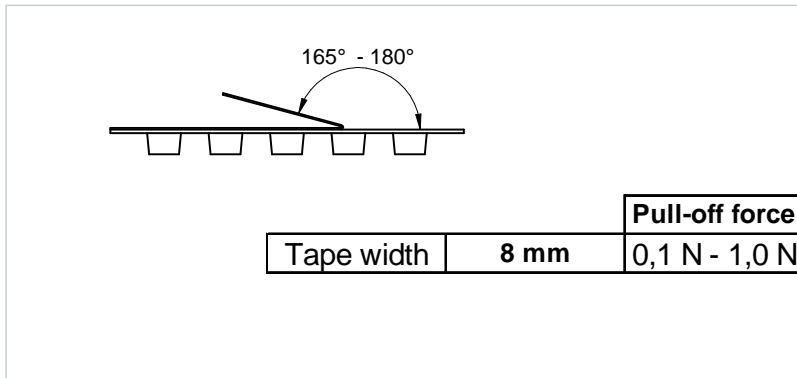

ORDER SAMPLES **SIMULATE IN REDEXPERT**



Packaging Specification

Size 2508

Packaging Specification - Tape: [mm]

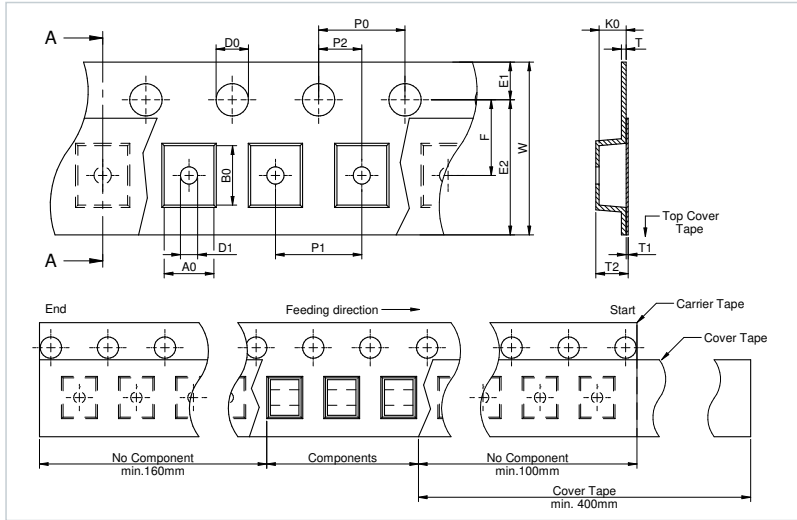

Packaging is referred to the international standard **IEC 60286-3:2019**

	Tape Type	A0 (mm)	B0 (mm)	W (mm)	T (mm)	T1 (mm)	T2 (mm)	K0 (mm)	P0 (mm)
Tolerance		typ.	typ.	+0,3/ -0,1	ref.	ref.	typ.	typ.	±0,1
Value	2a	2,30	2,75	8,00	0,22	0,10	1,80	1,17	4,00
	P1 (mm)	P2 (mm)	D0 (mm)	D1 (mm)	E1 (mm)	E2 (mm)	F (mm)	Material	Qty. (pcs.)
Tolerance	±0,1	±0,05	+0,1/ -0,0	min.	±0,1	min.	±0,05		
Value	4,00	2,00	1,50	0,30	1,75	6,25	3,50	Polystyrene	3000

Packaging Specification - Reel: [mm]

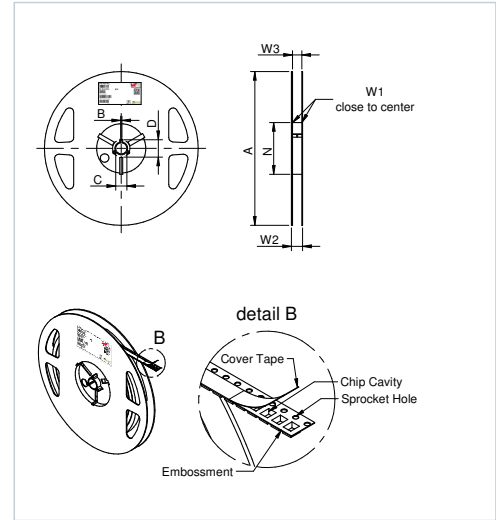

	A (mm)	B (mm)	C (mm)	D (mm)	N (mm)
Tolerance	± 2,0	min.	min.	min.	min.
Value	178	1,5	12,8	20,2	50
	W1 (mm)	W2 (mm)	W3 (mm)	W3 (mm)	Material
Tolerance	+1,5	max.	min.	max.	
Value	8,4	14,4	7,9	10,9	Polystyrene Polyurethane

Pull of Force:

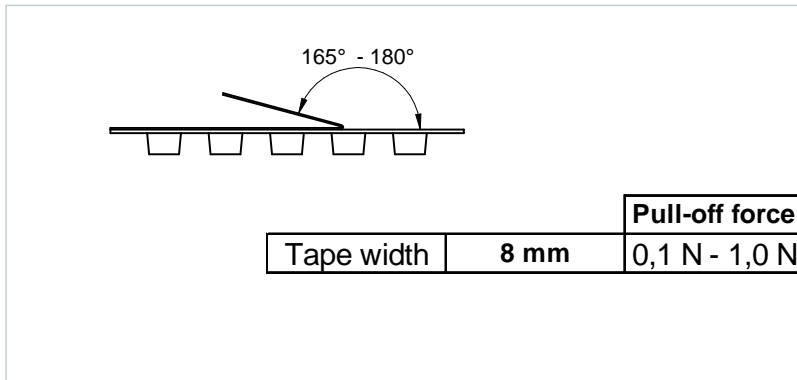

ORDER SAMPLES **SIMULATE IN REDEXPERT**



Packaging Specification

Size 2510

Packaging Specification - Tape: [mm]

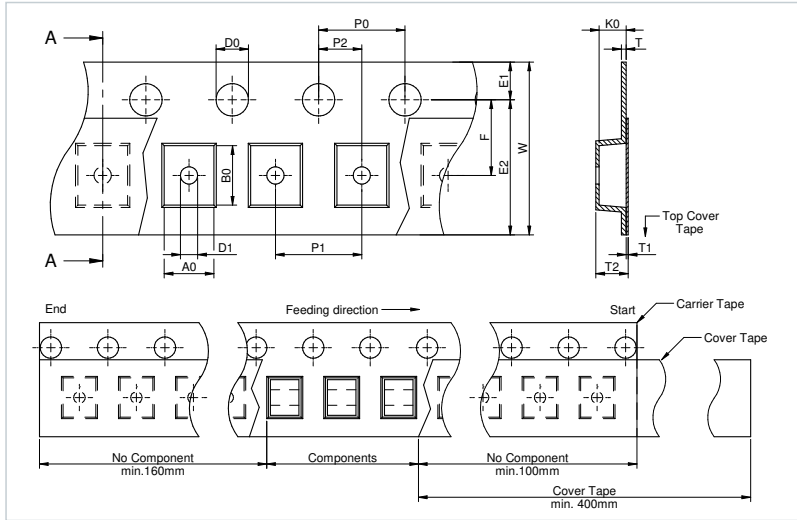

Packaging is referred to the international standard **IEC 60286-3:2019**

	Tape Type	A0 (mm)	B0 (mm)	W (mm)	T (mm)	T1 (mm)	T2 (mm)	K0 (mm)	P0 (mm)
Tolerance		typ.	typ.	+0,3/ -0,1	ref.	ref.	typ.	typ.	±0,1
Value	2a	2,30	2,75	8,00	0,22	0,10	1,80	1,30	4,00
	P1 (mm)	P2 (mm)	D0 (mm)	D1 (mm)	E1 (mm)	E2 (mm)	F (mm)	Material	Qty. (pcs.)
Tolerance	±0,1	±0,05	+0,1/ -0,0	min.	±0,1	min.	±0,05		
Value	4,00	2,00	1,50	0,30	1,75	6,25	3,50	Polystyrene	3000

Packaging Specification - Reel: [mm]

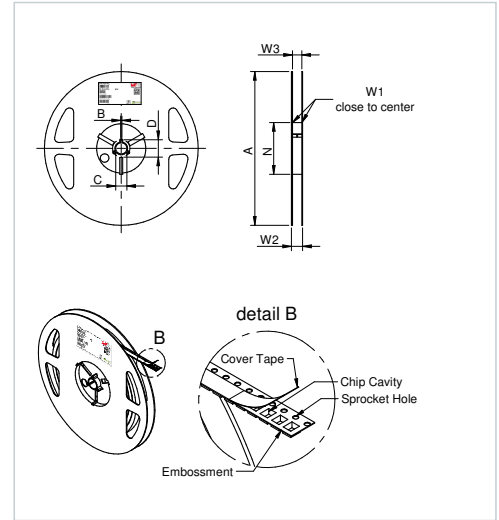

	A (mm)	B (mm)	C (mm)	D (mm)	N (mm)
Tolerance	± 2,0	min.	min.	min.	min.
Value	178	1,5	12,8	20,2	50
	W1 (mm)	W2 (mm)	W3 (mm)	W3 (mm)	Material
Tolerance	+1,5	max.	min.	max.	
Value	8,4	14,4	7,9	10,9	Polystyrene Polyurethane

Pull of Force:

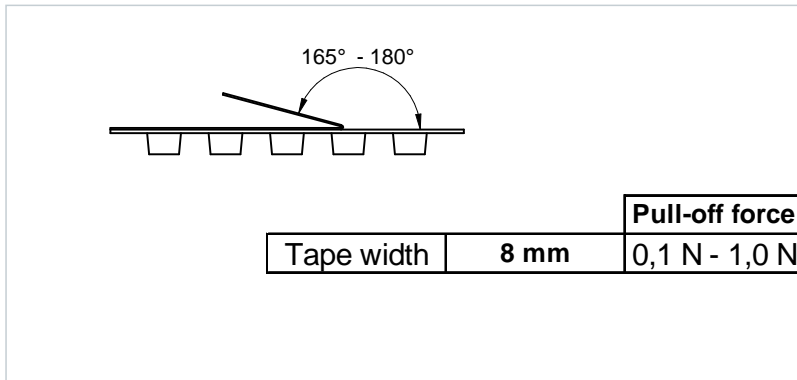

ORDER SAMPLES **SIMULATE IN REDEXPERT**



Packaging Specification

Size 2512

Packaging Specification - Tape: [mm]

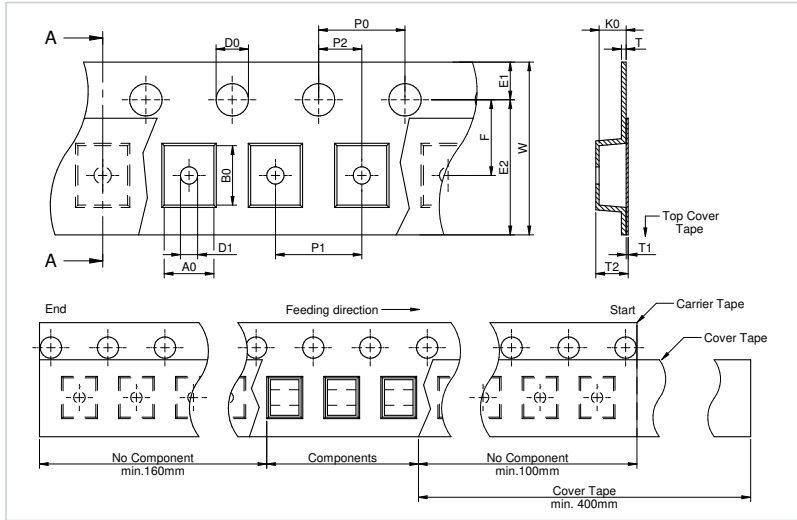

Packaging is referred to the international standard **IEC 60286-3:2019**

	Tape Type	A0 (mm)	B0 (mm)	W (mm)	T (mm)	T1 (mm)	T2 (mm)	K0 (mm)	P0 (mm)
Tolerance		typ.	typ.	+0,3/ -0,1	ref.	ref.	typ.	typ.	±0,1
Value	2a	2,30	2,75	8,00	0,22	0,10	1,80	1,30	4,00
	P1 (mm)	P2 (mm)	D0 (mm)	D1 (mm)	E1 (mm)	E2 (mm)	F (mm)	Material	Qty. (pcs.)
Tolerance	±0,1	±0,05	+0,1/ -0,0	min.	±0,1	min.	±0,05		
Value	4,00	2,00	1,50	0,30	1,75	6,25	3,50	Polystyrene	3000

Packaging Specification - Reel: [mm]

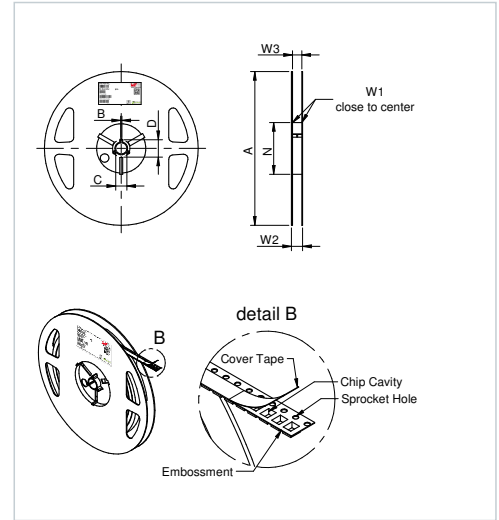

	A (mm)	B (mm)	C (mm)	D (mm)	N (mm)
Tolerance	± 2,0	min.	min.	min.	min.
Value	178	1,5	12,8	20,2	50
	W1 (mm)	W2 (mm)	W3 (mm)	W3 (mm)	Material
Tolerance	+1,5	max.	min.	max.	
Value	8,4	14,4	7,9	10,9	Polystyrene Polyurethane

Pull of Force:

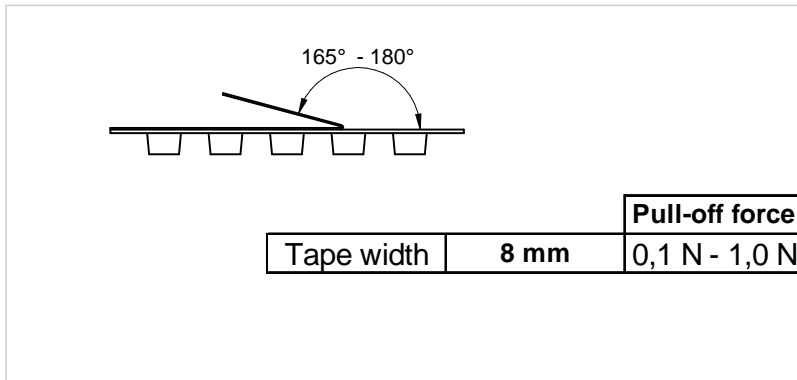

ORDER SAMPLES **SIMULATE IN REDEXPERT**



Packaging Specification

Size 3010

Packaging Specification - Tape: [mm]

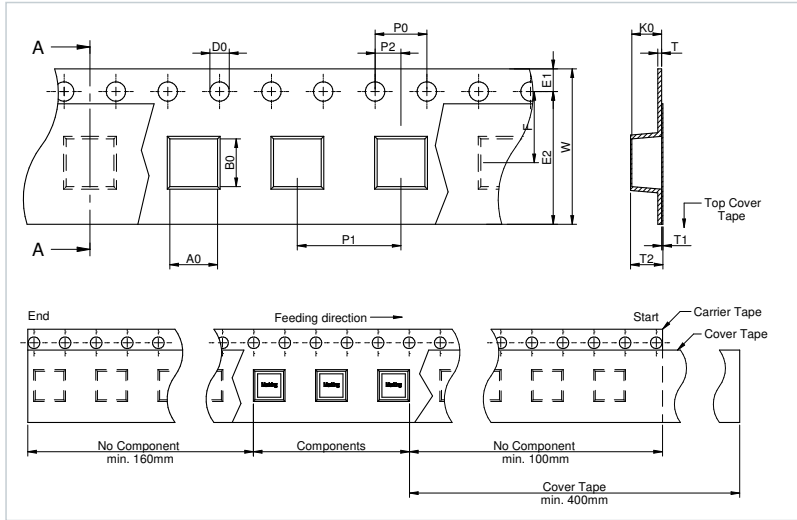

Packaging is referred to the international standard **IEC 60286-3:2019**

	Tape Type	A0 (mm)	B0 (mm)	W (mm)	T (mm)	T1 (mm)	T2 (mm)	K0 (mm)	P0 (mm)
Tolerance		typ.	typ.	+0,3/ -0,1	ref.	ref.	±0,25	±0,15	±0,1
Value	2a	3,68	3,68	12,00	0,30	0,10	2,00	1,50	4,00
	P1 (mm)	P2 (mm)	D0 (mm)	E1 (mm)	E2 (mm)	F (mm)	Material	Qty. (pcs.)	
Tolerance	±0,1	±0,05	+0,1/ -0,0	±0,1	min.	±0,05			
Value	8,00	2,00	1,50	1,75	10,25	5,50	Polystyrene	1000	

Packaging Specification - Reel: [mm]

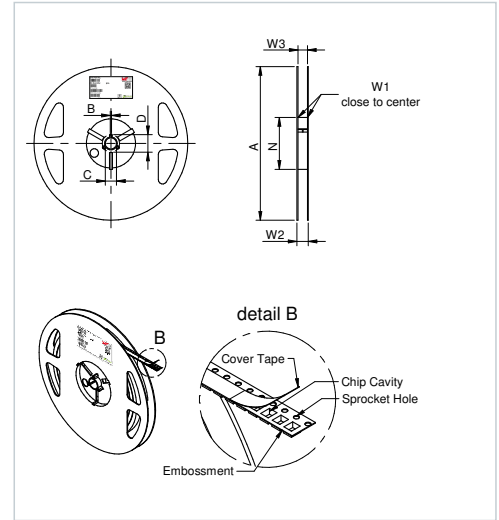

	A (mm)	B (mm)	C (mm)	D (mm)	N (mm)
Tolerance	± 2,0	min.	min.	min.	min.
Value	178,00	1,50	12,80	20,20	50,00
	W1 (mm)	W2 (mm)	W3 (mm)	W3 (mm)	Material
Tolerance	+ 2,0	max.	min.	max.	
Value	12,40	18,40	11,90	15,40	Polystyrene/ Polyurethane

Pull of Force:

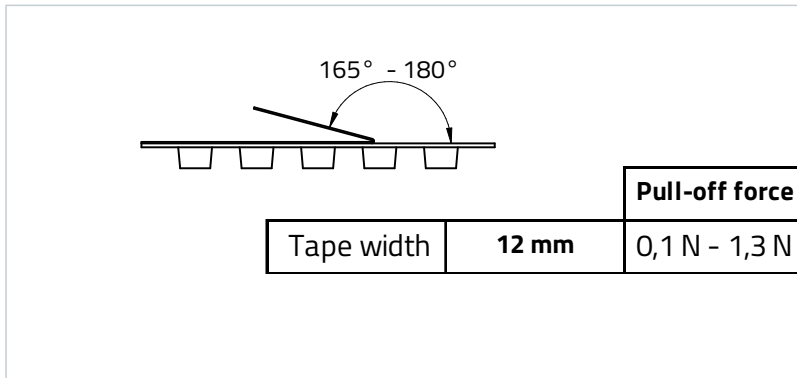

ORDER SAMPLES **SIMULATE IN REDEXPERT**



Packaging Specification

Size 3012

Packaging Specification - Tape: [mm]

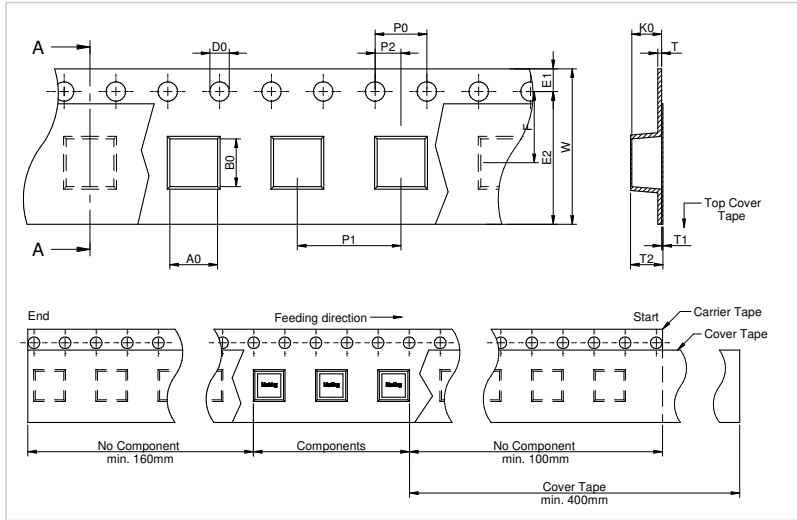

Packaging is referred to the international standard **IEC 60286-3:2019**

	Tape Type	A0 (mm)	B0 (mm)	W (mm)	T (mm)	T1 (mm)	T2 (mm)	K0 (mm)	P0 (mm)
Tolerance		typ.	typ.	+0,3/ -0,1	ref.	ref.	±0,25	±0,15	±0,1
Value	2a	3,50	3,68	12,00	0,30	0,10	2,00	1,50	4,00
	P1 (mm)	P2 (mm)	D0 (mm)	E1 (mm)	E2 (mm)	F (mm)	Material	Qty. (pcs.)	
Tolerance	±0,1	±0,05	+0,1/ -0,0	±0,1	min.	±0,05			
Value	8,00	2,00	1,50	1,75	10,25	5,50	Polystyrene	1000	

Packaging Specification - Reel: [mm]

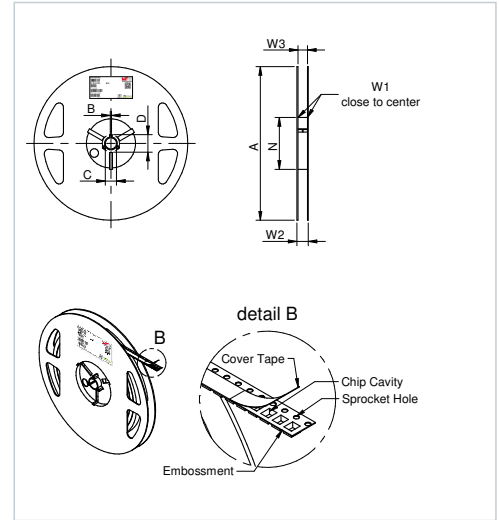

	A (mm)	B (mm)	C (mm)	D (mm)	N (mm)
Tolerance	± 2,0	min.	min.	min.	min.
Value	178,00	1,50	12,80	20,20	50,00
	W1 (mm)	W2 (mm)	W3 (mm)	W3 (mm)	Material
Tolerance	+ 2,0	max.	min.	max.	
Value	12,40	18,40	11,90	15,40	Polystyrene/ Polyurethane

Pull of Force:

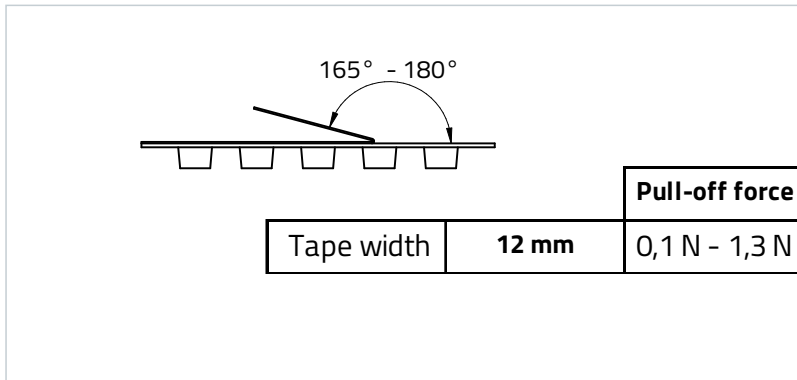

ORDER SAMPLES **SIMULATE IN REDEXPERT**



Packaging Specification

Size 3015

Packaging Specification - Tape: [mm]

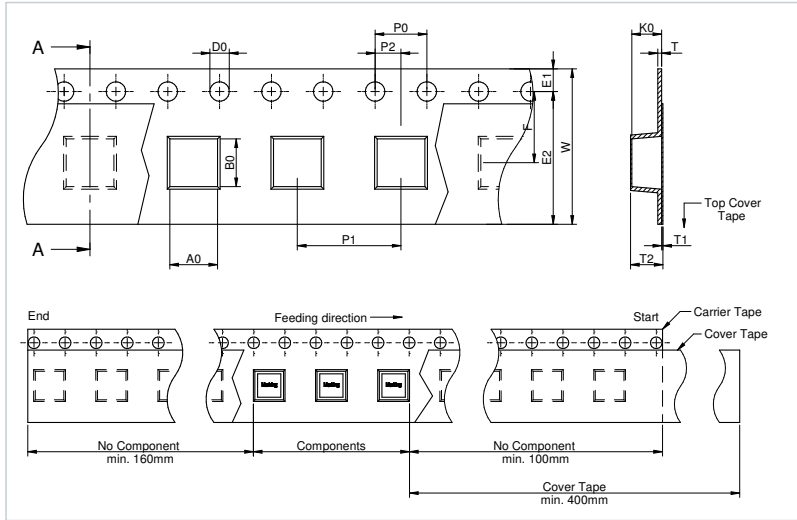

Packaging is referred to the international standard **IEC 60286-3:2019**

	Tape Type	A0 (mm)	B0 (mm)	W (mm)	T (mm)	T1 (mm)	T2 (mm)	K0 (mm)	P0 (mm)
Tolerance		typ.	typ.	+0,3/ -0,1	ref.	ref.	±0,25	±0,15	±0,1
Value	2a	3,50	3,68	12,00	0,30	0,10	2,00	1,50	4,00
	P1 (mm)	P2 (mm)	D0 (mm)	E1 (mm)	E2 (mm)	F (mm)	Material	Qty. (pcs.)	
Tolerance	±0,1	±0,05	+0,1/ -0,0	±0,1	min.	±0,05			
Value	8,00	2,00	1,50	1,75	10,25	5,50	Polystyrene	1000	

Packaging Specification - Reel: [mm]

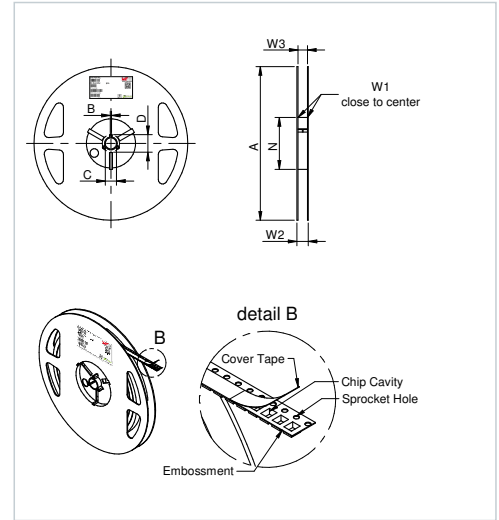

	A (mm)	B (mm)	C (mm)	D (mm)	N (mm)
Tolerance	± 2,0	min.	min.	min.	min.
Value	178,00	1,50	12,80	20,20	50,00
	W1 (mm)	W2 (mm)	W3 (mm)	W3 (mm)	Material
Tolerance	+ 2,0	max.	min.	max.	
Value	12,40	18,40	11,90	15,40	Polystyrene/ Polyurethane

Pull of Force:

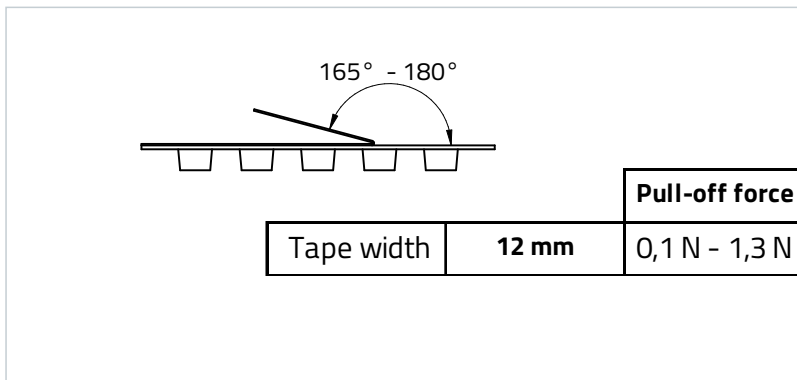

ORDER SAMPLES **SIMULATE IN REDEXPERT**



Packaging Specification

Size 3020

Packaging Specification - Tape: [mm]

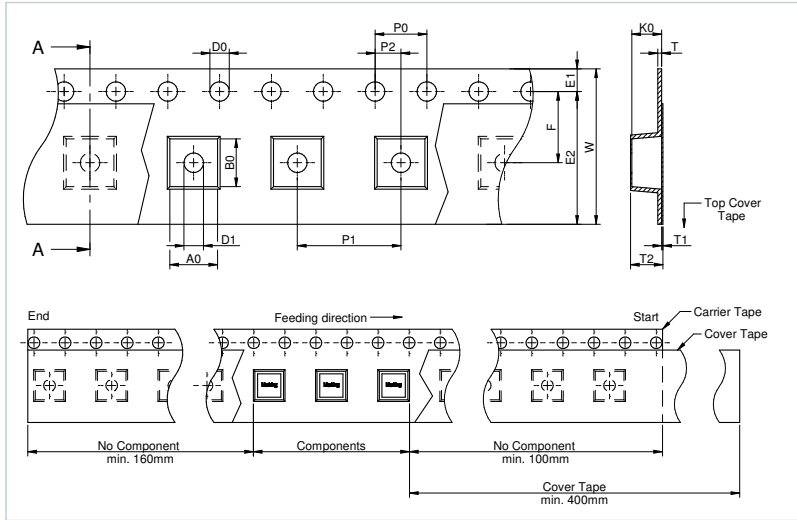

Packaging is referred to the international standard **IEC 60286-3:2019**

	Tape Type	A0 (mm)	B0 (mm)	W (mm)	T (mm)	T1 (mm)	T2 (mm)	K0 (mm)	P0 (mm)
Tolerance		typ.	typ.	+0,3/ -0,1	ref.	ref.	±0,25	±0,15	±0,1
Value	2a	3,68	3,68	12,00	0,30	0,10	2,30	2,30	4,00
	P1 (mm)	P2 (mm)	D0 (mm)	D1 (mm)	E1 (mm)	E2 (mm)	F (mm)	Material	Qty. (pcs.)
Tolerance	±0,1	±0,05	+0,1/ -0,0	min.	±0,1	min.	±0,05		
Value	8,00	2,00	1,50	1,50	1,75	10,25	5,50	Polystyrene	1000

Packaging Specification - Reel: [mm]

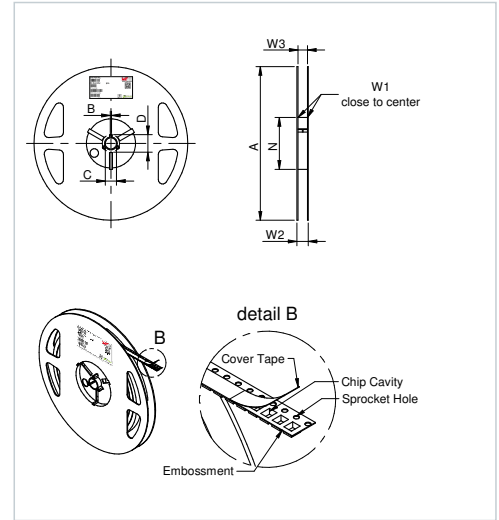

	A (mm)	B (mm)	C (mm)	D (mm)	N (mm)
Tolerance	± 2,0	min.	min.	min.	min.
Value	178,00	1,50	12,80	20,20	50,00
	W1 (mm)	W2 (mm)	W3 (mm)	W3 (mm)	Material
Tolerance	+ 2,0	max.	min.	max.	
Value	12,40	18,40	11,90	15,40	Polystyrene/ Polyurethane

Pull of Force:

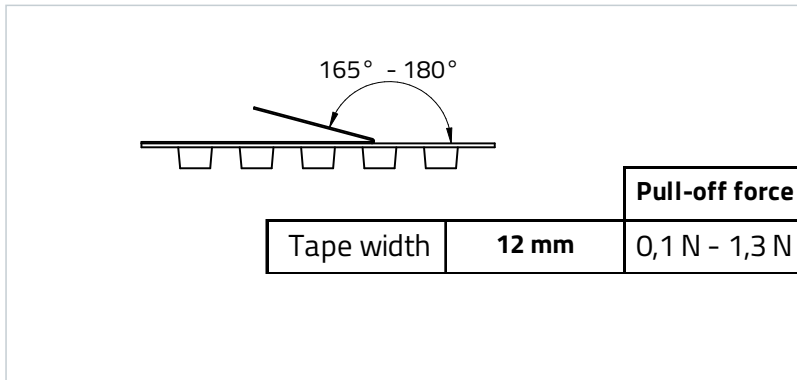

ORDER SAMPLES **SIMULATE IN REDEXPERT**



Packaging Specification

Size 4020

Packaging Specification - Tape: [mm]

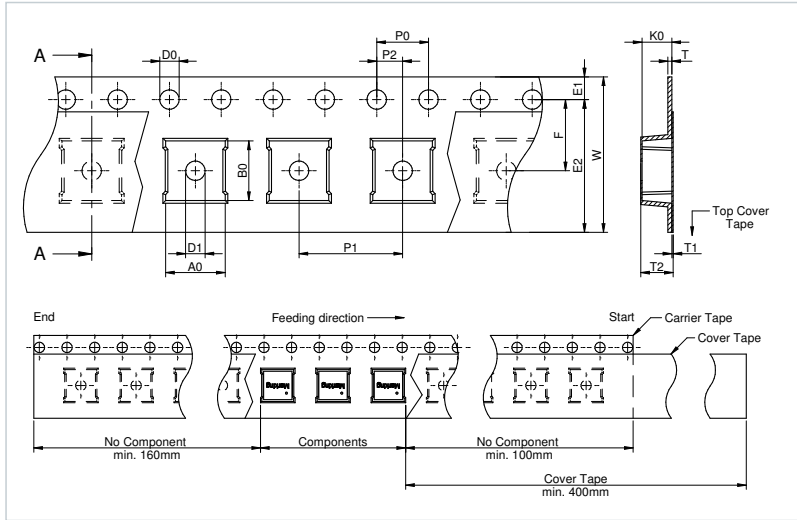

Packaging is referred to the international standard **IEC 60286-3:2019**

	Tape Type	A0 (mm)	B0 (mm)	W (mm)	T (mm)	T1 (mm)	T2 (mm)	K0 (mm)	P0 (mm)
Tolerance		typ.	typ.	+0,3/ -0,1	ref.	ref.	±0,25	±0,15	±0,1
Value	2a	4,60	4,60	12,00	0,30	0,10	2,50	2,30	4,00
	P1 (mm)	P2 (mm)	D0 (mm)	D1 (mm)	E1 (mm)	E2 (mm)	F (mm)	Material	Qty. (pcs.)
Tolerance	±0,1	±0,05	+0,1/ -0,0	min.	±0,1	min.	±0,05		
Value	8,00	2,00	1,50	1,50	1,75	10,25	5,50	Polystyrene	1000

Packaging Specification - Reel: [mm]

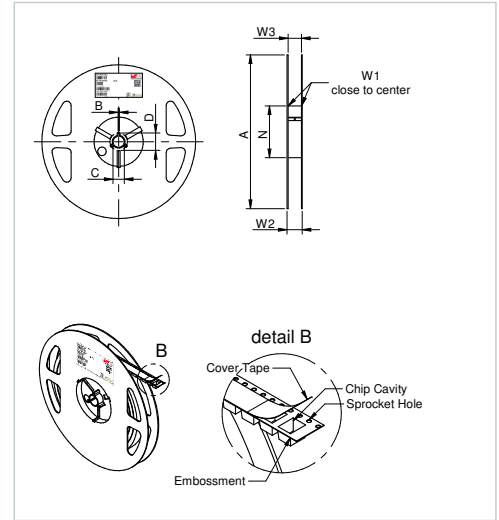

	A (mm)	B (mm)	C (mm)	D (mm)	N (mm)
Tolerance	± 2,0	min.	min.	min.	min.
Value	178,00	1,50	12,80	20,20	50,00
	W1 (mm)	W2 (mm)	W3 (mm)	W3 (mm)	Material
Tolerance	+ 2,0	max.	min.	max.	
Value	12,40	18,40	11,90	15,40	Polystyrene/ Polyurethane

Pull of Force:

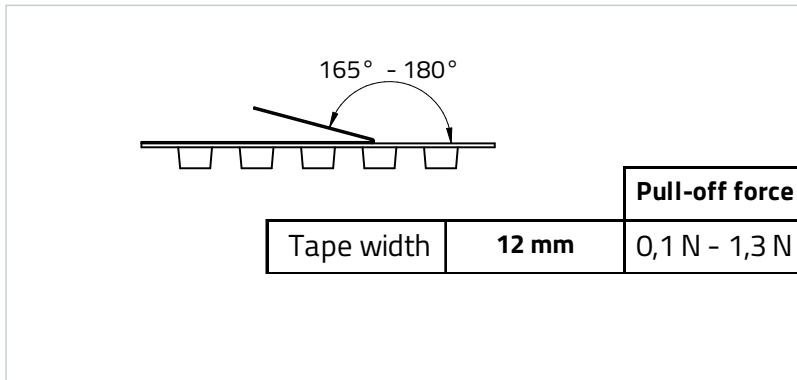

ORDER SAMPLES **SIMULATE IN REDEXPERT**



Packaging Specification

Size 4020HT

Packaging Specification - Tape: [mm]

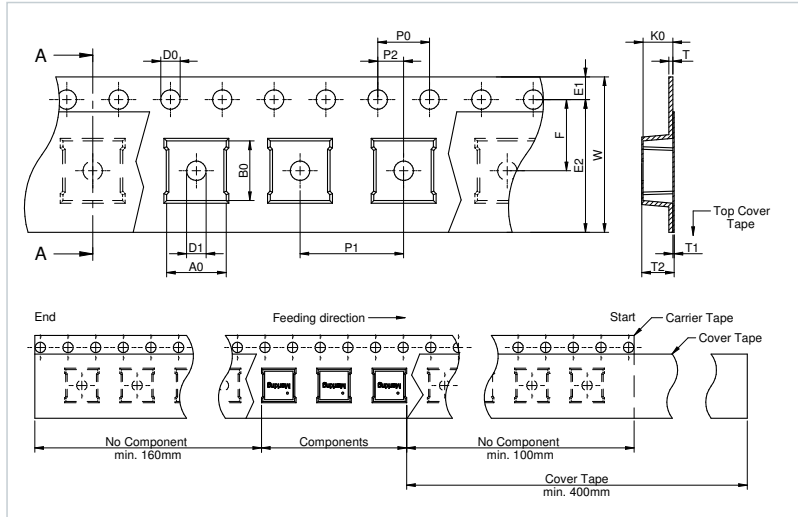

Packaging is referred to the international standard **IEC 60286-3:2019**

	Tape Type	A0 (mm)	B0 (mm)	W (mm)	T (mm)	T1 (mm)	T2 (mm)	K0 (mm)	P0 (mm)
Tolerance		typ.	typ.	+0,3/ -0,1	ref.	ref.	±0,25	±0,15	±0,1
Value	2a	4,60	4,60	12,00	0,30	0,10	2,50	2,30	4,00
	P1 (mm)	P2 (mm)	D0 (mm)	D1 (mm)	E1 (mm)	E2 (mm)	F (mm)	Material	Qty. (pcs.)
Tolerance	±0,1	±0,05	+0,1/ -0,0	min.	±0,1	min.	±0,05		
Value	8,00	2,00	1,50	1,50	1,75	10,25	5,50	Polystyrene	1000

Packaging Specification - Reel: [mm]

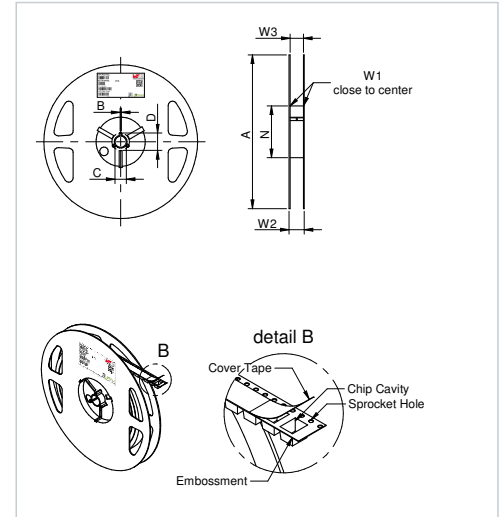

	A (mm)	B (mm)	C (mm)	D (mm)	N (mm)
Tolerance	± 2,0	min.	min.	min.	min.
Value	178,00	1,50	12,80	20,20	50,00
	W1 (mm)	W2 (mm)	W3 (mm)	W3 (mm)	Material
Tolerance	+ 2,0	max.	min.	max.	
Value	12,40	18,40	11,90	15,40	Polystyrene/ Polyurethane

Pull of Force:

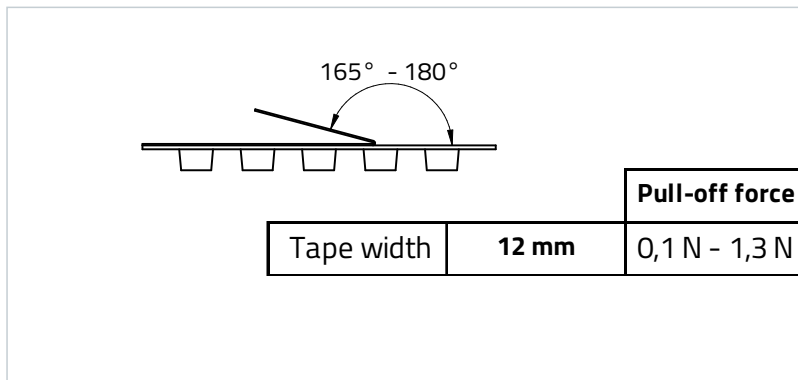

ORDER SAMPLES **SIMULATE IN REDEXPERT**



Packaging Specification

Size 4030

Packaging Specification - Tape: [mm]

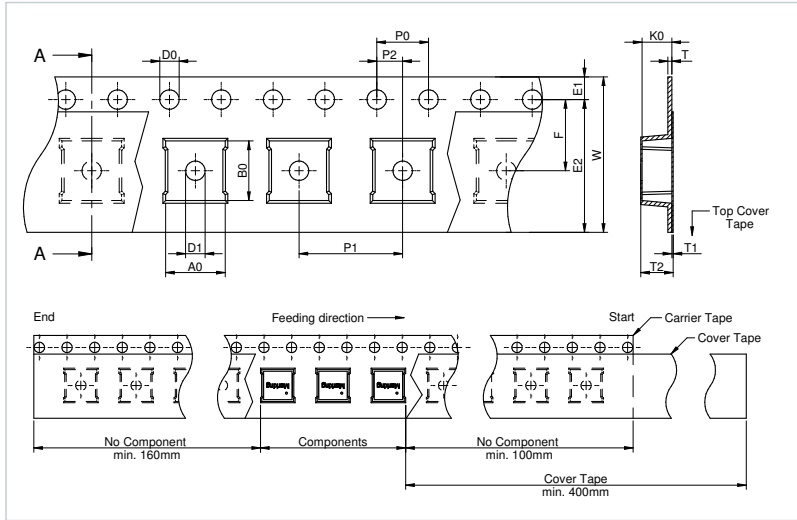

Packaging is referred to the international standard **IEC 60286-3:2019**

	Tape Type	A0 (mm)	B0 (mm)	W (mm)	T (mm)	T1 (mm)	T2 (mm)	K0 (mm)	P0 (mm)
Tolerance		typ.	typ.	+0,3/ -0,1	ref.	ref.	±0,25	±0,15	±0,1
Value	2a	4,60	4,60	12,00	0,30	0,10	3,50	3,30	4,00
	P1 (mm)	P2 (mm)	D0 (mm)	D1 (mm)	E1 (mm)	E2 (mm)	F (mm)	Material	Qty. (pcs.)
Tolerance	±0,1	±0,05	+0,1/ -0,0	min.	±0,1	min.	±0,05		
Value	8,00	2,00	1,50	1,50	1,75	10,25	5,50	Polystyrene	700

Packaging Specification - Reel: [mm]

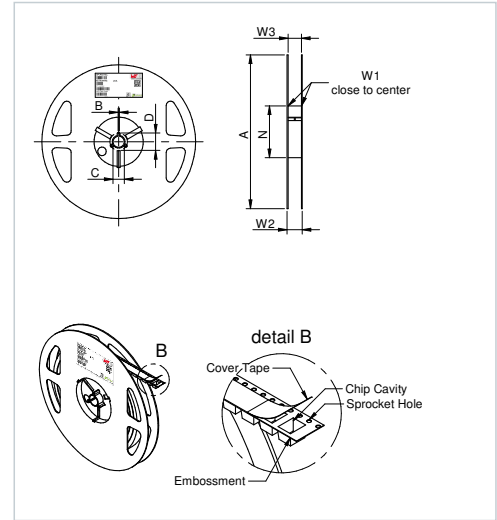

	A (mm)	B (mm)	C (mm)	D (mm)	N (mm)
Tolerance	± 2,0	min.	min.	min.	min.
Value	178,00	1,50	12,80	20,20	50,00
	W1 (mm)	W2 (mm)	W3 (mm)	W3 (mm)	Material
Tolerance	+ 2,0	max.	min.	max.	
Value	12,40	18,40	11,90	15,40	Polystyrene/ Polyurethane

Pull of Force:

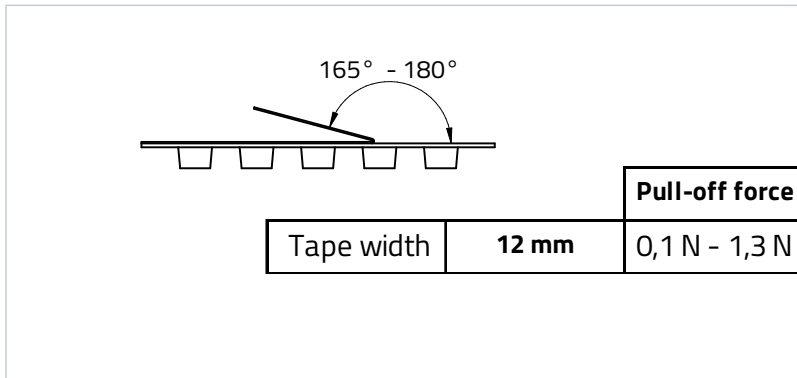

ORDER SAMPLES **SIMULATE IN REDEXPERT**



Packaging Specification

Size 5020

Packaging Specification - Tape: [mm]

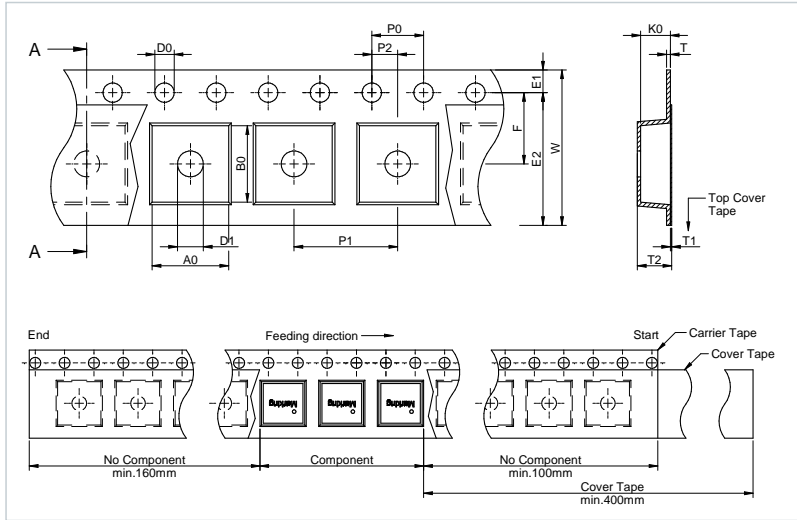

Packaging is referred to the international standard **IEC 60286-3:2019**

	Tape Type	A0 (mm)	B0 (mm)	W (mm)	T (mm)	T1 (mm)	T2 (mm)	K0 (mm)	P0 (mm)
Tolerance		typ.	typ.	+0,3/ -0,1	ref.	ref.	±0,25	±0,15	±0,1
Value	2a	5,90	5,90	12,00	0,30	0,10	2,50	2,30	4,00
	P1 (mm)	P2 (mm)	D0 (mm)	D1 (mm)	E1 (mm)	E2 (mm)	F (mm)	Material	Qty. (pcs.)
Tolerance	±0,1	±0,05	+0,1/ -0,0	min.	±0,1	min.	±0,05		
Value	8,00	2,00	1,50	1,50	1,75	10,25	5,50	Polystyrene	1000

Packaging Specification - Reel: [mm]

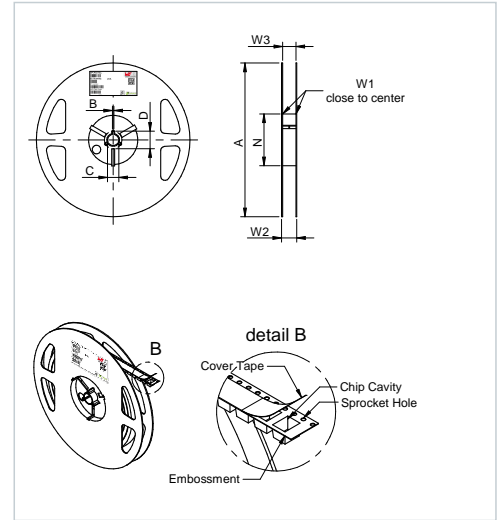

	A (mm)	B (mm)	C (mm)	D (mm)	N (mm)
Tolerance	+ 0,0/-3,0	min.	± 0,2	min.	+ 1,0/-0,0
Value	180,00	1,50	13,00	20,20	60,00
	W1 (mm)	W2 (mm)	W3 (mm)	Material	
Tolerance	+ 2,0	max.	± 0,5	max.	
Value	12,40	18,40	13,00	13,50	

Pull of Force:

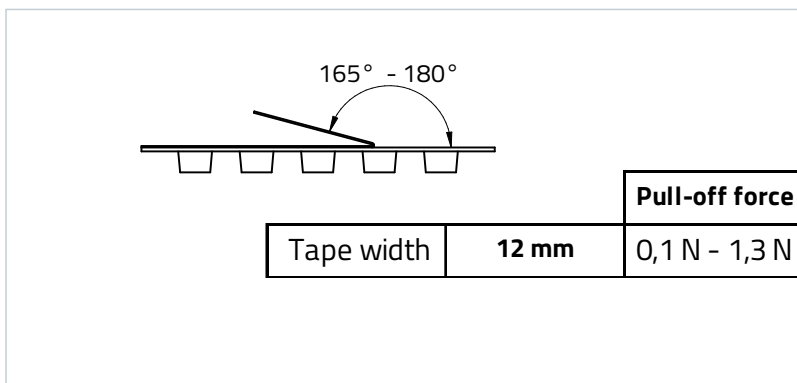

ORDER SAMPLES **SIMULATE IN REDEXPERT**



Packaging Specification

Size 5020

Packaging Specification - Reel in Carton: [mm]

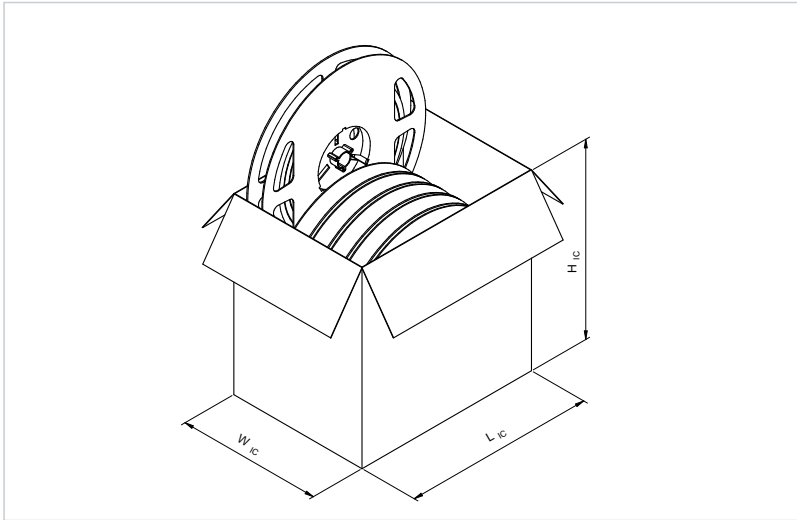

	L _{1c} (mm)	W _{1c} (mm)	H _{1c} (mm)	No. of Reel (pcs.)	Qty. (pcs.)	Material
Tolerance	typ.	typ.	typ.			
Value	185,00	140,00	190,00	6	6000	Paper

Packaging Specification - Outer Carton: [mm]

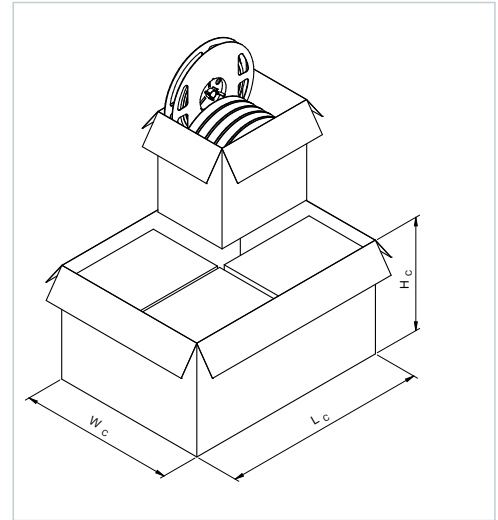

	L _c (mm)	W _c (mm)	H _c (mm)	No. of Inner Carton (pcs.)	Qty. (pcs.)	Material
Tolerance	typ.	typ.	typ.			
Value	390,00	295,00	215,00	4	24000	Paper

ORDER SAMPLES

SIMULATE IN REDEXPERT



Packaging Specification

Size 5030

Packaging Specification - Tape: [mm]

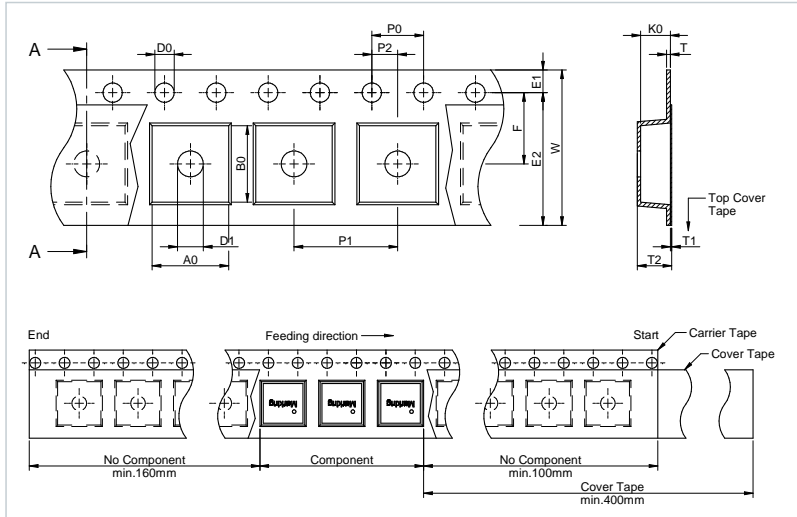

Packaging is referred to the international standard IEC 60286-3:2019

	Tape Type	A0 (mm)	B0 (mm)	W (mm)	T (mm)	T1 (mm)	T2 (mm)	K0 (mm)	P0 (mm)
Tolerance		typ.	typ.	+0,3/ -0,1	ref.	ref.	±0,25	±0,15	±0,1
Value	2a	5,90	5,90	12,00	0,30	0,10	3,50	3,30	4,00
	P1 (mm)	P2 (mm)	D0 (mm)	D1 (mm)	E1 (mm)	E2 (mm)	F (mm)	Material	Qty. (pcs.)
Tolerance	±0,1	±0,05	+0,1/ -0,0	min.	±0,1	min.	±0,05		
Value	8,00	2,00	1,50	1,50	1,75	10,25	5,50	Polystyrene	700

Packaging Specification - Reel: [mm]

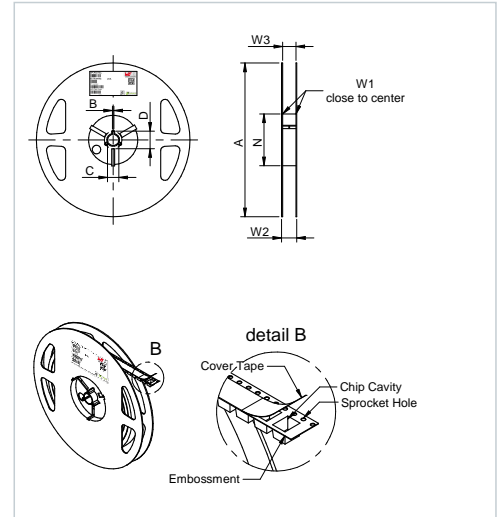

	A (mm)	B (mm)	C (mm)	D (mm)	N (mm)
Tolerance	+ 0,0/-3,0	min.	± 0,2	min.	+ 1,0/-0,0
Value	180,00	1,50	13,00	20,20	60,00
	W1 (mm)	W2 (mm)	W3 (mm)	Material	
Tolerance	+ 2,0	max.	± 0,5	max.	
Value	12,40	18,40	13,00	13,50	Polystyrene

Pull of Force:

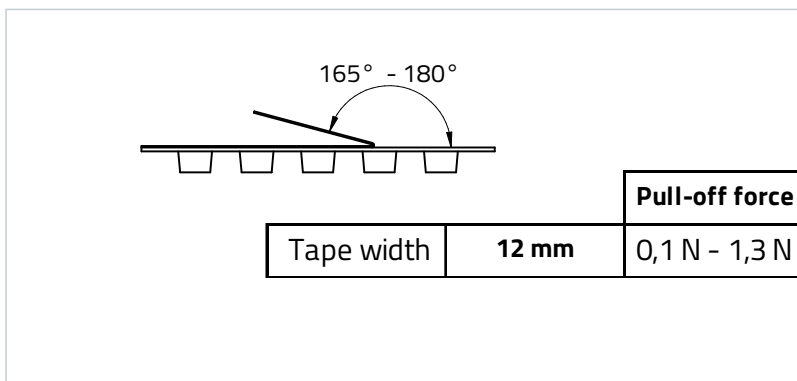

ORDER SAMPLES **SIMULATE IN REDEXPERT**



Packaging Specification

Size 5030

Packaging Specification - Reel in Carton: [mm]

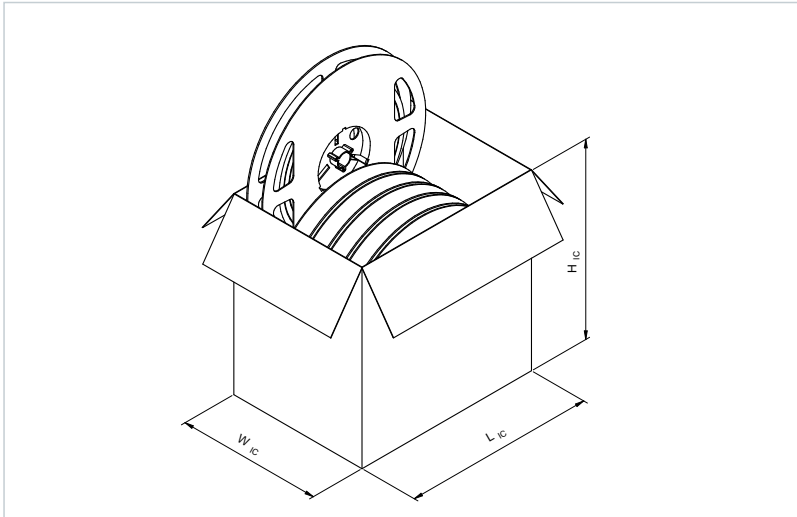

	L_{1c} (mm)	W_{1c} (mm)	H_{1c} (mm)	No. of Reel (pcs.)	Qty. (pcs.)	Material
Tolerance	typ.	typ.	typ.			
Value	185,00	140,00	190,00	6	4200	Paper

Packaging Specification - Outer Carton: [mm]

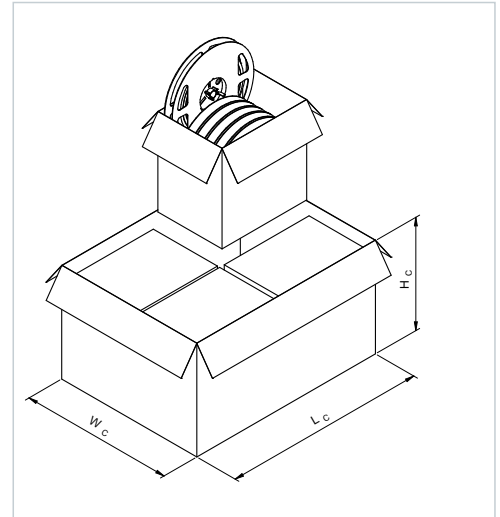

	L_c (mm)	W_c (mm)	H_c (mm)	No. of Inner Carton (pcs.)	Qty. (pcs.)	Material
Tolerance	typ.	typ.	typ.			
Value	390,00	295,00	215,00	4	16800	Paper

ORDER SAMPLES

SIMULATE IN REDEXPERT



Soldering Profile

Size 1610, 2506, 2508, 2510, 2512, 3010, 3012, 3015, 3020, 4020, 4020HT, 4030, 5020, 5030

Classification Reflow Profile for SMT components:

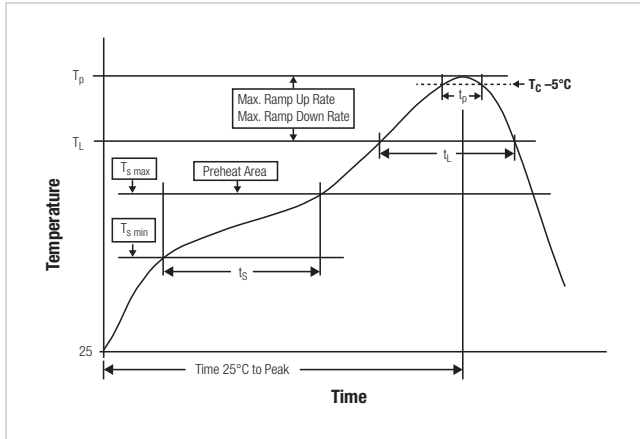

Classification Reflow Soldering Profile:

Profile Feature		Value
Preheat Temperature Min	$T_{s \text{ min}}$	150 °C
Preheat Temperature Max	$T_{s \text{ max}}$	200 °C
Preheat Time t_s from $T_{s \text{ min}}$ to $T_{s \text{ max}}$	t_s	60 - 120 seconds
Ramp-up Rate (T_L to T_p)		3 °C/ second max.
Liquidous Temperature	T_L	217 °C
Time t_L maintained above T_L	t_L	60 - 150 seconds
Peak package body temperature	T_p	$T_p \leq T_c$, see Table below
Time within 5 °C of actual peak temperature	t_p	20 - 30 seconds
Ramp-down Rate (T_p to T_L)		6 °C/ second max.
Time 25 °C to peak temperature		8 minutes max.

refer to IPC/ JEDEC J-STD-020E

Make sure that you use the correct thickness of solder paste to avoid an insufficient soldering result. We recommend 100µm solder paste as a reference.

Package Classification Reflow Temperature (T_c):

Properties	Volume mm ³ <350	Volume mm ³ 350-2000	Volume mm ³ >2000
PB-Free Assembly Package Thickness < 1.6 mm	260 °C	260 °C	260 °C
PB-Free Assembly Package Thickness 1.6 mm - 2.5 mm	260 °C	250 °C	245 °C
PB-Free Assembly Package Thickness > 2.5 mm	250 °C	245 °C	245 °C

refer to IPC/ JEDEC J-STD-020E

ORDER SAMPLES

SIMULATE IN REDEXPERT



Cautions and Warnings:

The following conditions apply to all goods within the product series of WE-MAIA of Würth Elektronik eiSos GmbH & Co. KG:

General:

- This electronic component is designed and manufactured for use in general electronic equipment.
- Würth Elektronik must be asked for written approval (following the PPAP procedure) before incorporating the components into any equipment in fields such as military, aerospace, aviation, nuclear control, submarine, transportation (automotive control, train control, ship control), transportation signal, disaster prevention, medical, public information network, etc. where higher safety and reliability are especially required and/or if there is the possibility of direct damage or human injury.
- Electronic components that will be used in safety-critical or high-reliability applications, should be pre-evaluated by the customer.
- The component is designed and manufactured to be used within the datasheet specified values. If the usage and operation conditions specified in the datasheet are not met, the wire insulation may be damaged or dissolved.
- Do not drop or impact the components, the component may be damaged.
- Würth Elektronik products are qualified according to international standards, which are listed in each product reliability report. Würth Elektronik does not warrant any customer qualified product characteristics beyond Würth Elektronik's specifications, for its validity and sustainability over time.
- The responsibility for the applicability of the customer specific products and use in a particular customer design is always within the authority of the customer. All technical specifications for standard products also apply to customer specific products.

Product specific:

Soldering:

- The solder profile must comply with the technical product specifications. All other profiles will void the warranty.
- All other soldering methods are at the customers' own risk.
- To improve the solderability of bottom termination components please refer to appnote ANPO36 on our homepage.
- Make sure that you use the correct thickness of solder paste to avoid an insufficient soldering result. We recommend 100µm solder paste as a reference.

Cleaning and Washing:

- Washing agents used during the production to clean the customer application might damage or change the characteristics of the wire insulation, marking or plating. Washing agents may have a negative effect on the long-term functionality of the product.

Potting:

- If the product is potted in the customer application, the potting material might shrink or expand during and after hardening. Shrinking could lead to an incomplete seal, allowing contaminants into the core. Expansion could damage the components. We recommend a manual inspection after potting to avoid these effects.

Storage Conditions:

- A storage of Würth Elektronik products for longer than 12 months is not recommended. Within other effects, the terminals may suffer degradation, resulting in bad solderability. Therefore, all products shall be used within the period of 12 months based on the day of shipment.
- Do not expose the components to direct sunlight.
- The storage conditions in the original packaging are defined according to DIN EN 61760-2.
- The storage conditions stated in the original packaging apply to the storage time and not to the transportation time of the components.

Packaging:

- The packaging specifications apply only to purchase orders comprising whole packaging units. If the ordered quantity exceeds or is lower than the specified packaging unit, packaging in accordance with the packaging specifications cannot be ensured.

Handling:

- Violation of the technical product specifications such as exceeding the nominal rated current will void the warranty.
- Applying currents with audio-frequency signals may result in audible noise due to the magnetostrictive material properties.
- The temperature rise of the component must be taken into consideration. The operating temperature is comprised of ambient temperature and temperature rise of the component. The operating temperature of the component shall not exceed the maximum temperature specified.

These cautions and warnings comply with the state of the scientific and technical knowledge and are believed to be accurate and reliable. However, no responsibility is assumed for inaccuracies or incompleteness.

[ORDER
SAMPLES](#)[SIMULATE IN
REDEXPERT](#)

Important Notes

The following conditions apply to all goods within the product range of Würth Elektronik eiSos GmbH & Co. KG:

1. General Customer Responsibility

Some goods within the product range of Würth Elektronik eiSos GmbH & Co. KG contain statements regarding general suitability for certain application areas. These statements about suitability are based on our knowledge and experience of typical requirements concerning the areas, serve as general guidance and cannot be estimated as binding statements about the suitability for a customer application. The responsibility for the applicability and use in a particular customer design is always solely within the authority of the customer. Due to this fact it is up to the customer to evaluate, where appropriate to investigate and decide whether the device with the specific product characteristics described in the product specification is valid and suitable for the respective customer application or not.

2. Customer Responsibility related to Specific, in particular Safety-Relevant Applications

It has to be clearly pointed out that the possibility of a malfunction of electronic components or failure before the end of the usual lifetime cannot be completely eliminated in the current state of the art, even if the products are operated within the range of the specifications. In certain customer applications requiring a very high level of safety and especially in customer applications in which the malfunction or failure of an electronic component could endanger human life or health it must be ensured by most advanced technological aid of suitable design of the customer application that no injury or damage is caused to third parties in the event of malfunction or failure of an electronic component. Therefore, customer is cautioned to verify that data sheets are current before placing orders. The current data sheets can be downloaded at www.we-online.com.

3. Best Care and Attention

Any product-specific notes, cautions and warnings must be strictly observed. Any disregard will result in the loss of warranty.

4. Customer Support for Product Specifications

Some products within the product range may contain substances which are subject to restrictions in certain jurisdictions in order to serve specific technical requirements. Necessary information is available on request. In this case the field sales engineer or the internal sales person in charge should be contacted who will be happy to support in this matter.

5. Product R&D

Due to constant product improvement product specifications may change from time to time. As a standard reporting procedure of the Product Change Notification (PCN) according to the JEDEC-Standard inform about minor and major changes. In case of further queries regarding the PCN, the field sales engineer or the internal sales person in charge should be contacted. The basic responsibility of the customer as per Section 1 and 2 remains unaffected.

6. Product Life Cycle

Due to technical progress and economical evaluation we also reserve the right to discontinue production and delivery of products. As a standard reporting procedure of the Product Termination Notification (PTN) according to the JEDEC-Standard we will inform at an early stage about inevitable product discontinuance. According to this we cannot guarantee that all products within our product range will always be available. Therefore it needs to be verified with the field sales engineer or the internal

sales person in charge about the current product availability expectancy before or when the product for application design-in disposal is considered. The approach named above does not apply in the case of individual agreements deviating from the foregoing for customer-specific products.

7. Property Rights

All the rights for contractual products produced by Würth Elektronik eiSos GmbH & Co. KG on the basis of ideas, development contracts as well as models or templates that are subject to copyright, patent or commercial protection supplied to the customer will remain with Würth Elektronik eiSos GmbH & Co. KG. Würth Elektronik eiSos GmbH & Co. KG does not warrant or represent that any license, either expressed or implied, is granted under any patent right, copyright, mask work right, or other intellectual property right relating to any combination, application, or process in which Würth Elektronik eiSos GmbH & Co. KG components or services are used.

8. General Terms and Conditions

Unless otherwise agreed in individual contracts, all orders are subject to the current version of the "General Terms and Conditions of Würth Elektronik eiSos Group", last version available at www.we-online.com.

[ORDER
SAMPLES](#)[SIMULATE IN
REDEXPERT](#)