

## USER MANUAL

WSEN-PDUS

25131308XXXXX

VERSION 2.1

OCTOBER 25, 2024

**WÜRTH ELEKTRONIK** MORE THAN YOU EXPECT

## Revision history

Manual version	Notes	Date
1.0	<ul style="list-style-type: none"><li>• Initial release of the manual</li></ul>	August 2019
1.1	<ul style="list-style-type: none"><li>• Added parameters and values corresponding to part number 2513130815401 in sections 1.3, 2.3, 2.4.2(Table 11), 6.1 and 7.1</li></ul>	December 2021
2.0	<ul style="list-style-type: none"><li>• Update: new part numbers 2513130810102 and 2513130810402</li><li>• Added parameters and values corresponding to part numbers 2513130810102 and 2513130810402 in sections 1.3, 2.3, 2.4.3, 3, 6.1 and 7.2</li><li>• Added new section 8</li><li>• Updated section 9 with physical drawings and footprint for horizontal-barbed nozzles</li></ul>	July 2023
2.1	<ul style="list-style-type: none"><li>• Updated section Important notes and Legal notice</li></ul>	October 2024

## Abbreviations

Abbreviation	Description
ASIC	Application Specific Integrated Circuit
BFSL	Best Fit Straight Line
ESD	Electrostatic Discharge
EEPROM	Electrically erasable programmable read-only memory
FSS	Full Scale Span
HBM	Human Body Model
HVAC	Heating, ventilation and air conditioning
I <sup>2</sup> C	Inter Integrated Circuit
LCP	Liquid-crystal polymers
LSB	Least Significant Bit
MEMS	Micro-electro-mechanical system
MSB	Most Significant Bit
PCB	Printed Circuit Board

# Contents

<b>Overview of helpful application notes</b>	<b>5</b>
<b>1 Introduction</b>	<b>6</b>
1.1 Applications . . . . .	6
1.2 Key features . . . . .	6
1.3 Ordering information . . . . .	7
1.4 Block diagram . . . . .	8
<b>2 Sensor specifications</b>	<b>9</b>
2.1 General information . . . . .	9
2.2 Media compatibility . . . . .	9
2.3 Absolute maximum ratings . . . . .	10
2.4 Pressure sensor specifications . . . . .	11
2.4.1 Common paramters . . . . .	11
2.4.2 Part number specific parameters: 5V devices . . . . .	12
2.4.3 Part number specific parameters: 3.3V devices . . . . .	15
2.5 Temperature sensor specifications . . . . .	16
2.6 Electrical specifications . . . . .	16
<b>3 Pinning information</b>	<b>17</b>
3.1 Pin configuration . . . . .	17
3.2 Pin description . . . . .	18
<b>4 Digital interface</b>	<b>19</b>
4.1 General characteristics . . . . .	19
4.2 <i>SDA</i> and <i>SCL</i> logic levels . . . . .	20
4.3 Communication phase . . . . .	20
4.3.1 Idle state . . . . .	20
4.3.2 START (S) and STOP (P) condition . . . . .	20
4.3.3 Data validity . . . . .	21
4.3.4 Byte format . . . . .	21
4.3.5 Acknowledge (ACK) and No-Acknowledge (NACK) . . . . .	21
4.3.6 Slave address for the sensor . . . . .	22
4.3.7 Read operation . . . . .	23
4.4 I <sup>2</sup> C timing parameters . . . . .	24
<b>5 Application circuit</b>	<b>25</b>
<b>6 Reading digital output data</b>	<b>26</b>
6.1 Pressure output: digital . . . . .	27
6.2 Temperature output: digital . . . . .	28
6.3 Interpreting digital pressure values . . . . .	29
6.4 Interpreting digital temperature values . . . . .	30
<b>7 Reading analog pressure data</b>	<b>31</b>
7.1 Analog pressure output: 5V devices . . . . .	31
7.2 Analog pressure output: 3.3V devices . . . . .	32

<b>8</b>	<b>Look-up Table</b>	<b>33</b>
<b>9</b>	<b>Physical specifications</b>	<b>34</b>
9.1	Sensor drawing: Vertical Nozzles . . . . .	34
9.2	Sensor drawing: Horizontal-Barbed Nozzles . . . . .	35
9.3	Footprint . . . . .	36
9.4	Marking information . . . . .	37
<b>10</b>	<b>Manufacturing information</b>	<b>38</b>
10.1	Moisture sensitivity level . . . . .	38
10.2	Reflow soldering . . . . .	38
10.3	Cleaning and washing . . . . .	39
10.4	Potting and coating . . . . .	40
10.5	Storage conditions . . . . .	40
10.6	Handling . . . . .	40
<b>11</b>	<b>Important notes</b>	<b>41</b>
<b>12</b>	<b>Legal notice</b>	<b>41</b>
<b>13</b>	<b>License terms for Würth Elektronik eiSos GmbH &amp; Co. KG sensor product software and source code</b>	<b>42</b>

## Overview of helpful application notes

### Application note ANM001 - MEMS Sensor PCB design and soldering guideline

<http://www.we-online.com/ANM001>

This technical document provides necessary information and general guidelines for soldering and PCB design for the Würth Elektronik eiSos MEMS sensor products with an LGA surface-mount package.

### Application note ANR034 - How to use Zephyr sensor drivers

<http://www.we-online.com/ANR034>

The application note shows how to integrate the Zephyr drivers of Würth Elektronik eiSos sensors into the user's application source code to use Würth Elektronik eiSos sensors in the user's end device.

# 1 Introduction

The differential pressure sensors from Würth Elektronik eiSos allow measurement of pressure difference between two vertical pressure ports. The sensors consist of a MEMS based piezo-resistive sensing element and an ASIC integrated on a ceramic substrate. On-chip calibration, temperature compensation and signal conditioning provide highly accurate pressure in both digital and analog forms. Digital pressure data can be accessed by interfacing the sensor to the host controller via digital I<sup>2</sup>C interface. Simple communication protocol enables easy integration of the software, without the need of programming internal registers.

The sensors, available in various pressure ranges can measure differential pressure up to 10 bar. They are intended to be used for non-corrosive gases such as air and other dry gases (see section 2.2 for further information). The sensors come in 13 x 8 x 7.5 mm reflow solderable surface mount package with two pressure ports on top, allowing flexible mounting.

## 1.1 Applications

- HVAC
- Filter monitoring
- Gas leak detection
- Inhalers
- Fume hood

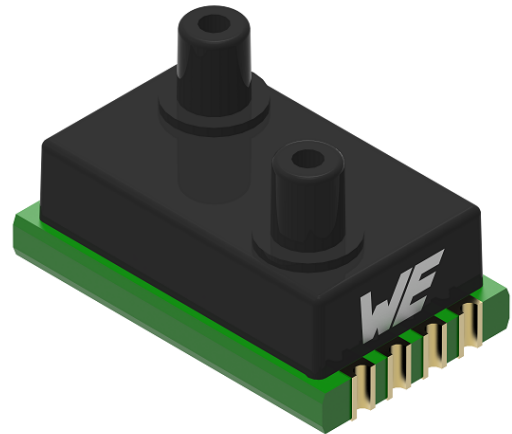

## 1.2 Key features

- Available in different pressure ranges
  - $\pm 0.1$  kPa
  - $\pm 1$  kPa
  - $\pm 10$  kPa
  - 0 to 100 kPa
  - -100 kPa to 1000 kPa
  - 0 to 1500 kPa
- Supply voltage: 5 V, 3.3 V
- Analog and digital output for pressure
- Communication interface: I<sup>2</sup>C
- Temperature range: -25 °C to 85 °C
- Typical current consumption: 4 mA

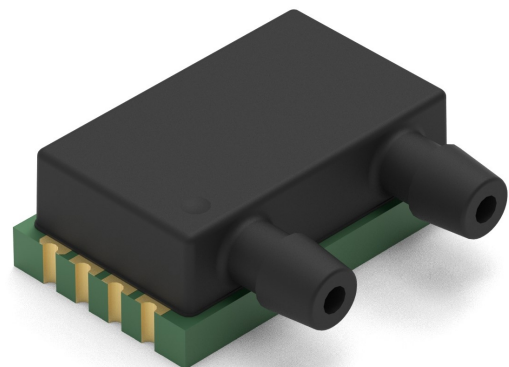

### 1.3 Ordering information

WE order code	Pressure range [kPa]	Marking	VDD	Dimensions [mm]	Description
2513130810001	± 0.1	PDB100IA0N	5V	13.3 x 8.0 x 7.5	Tape & reel packaging
2513130810101	± 1	PDB101IA0N			
2513130810201	± 10	PDB102IA0N			
2513130810301	0 to 100	PDU103IA0N			
2513130810401	-100 to 1000	PDU104IA0N			
2513130815401	0 to 1500	PDU154IA0N			
2513130810402	-100 to 1000	PDU104IA3N	3.3V	13.3 x 11.6 x 4.5	
2513130810102	± 1	PDB101IA3N			

Table 1: Ordering information



## 1.4 Block diagram

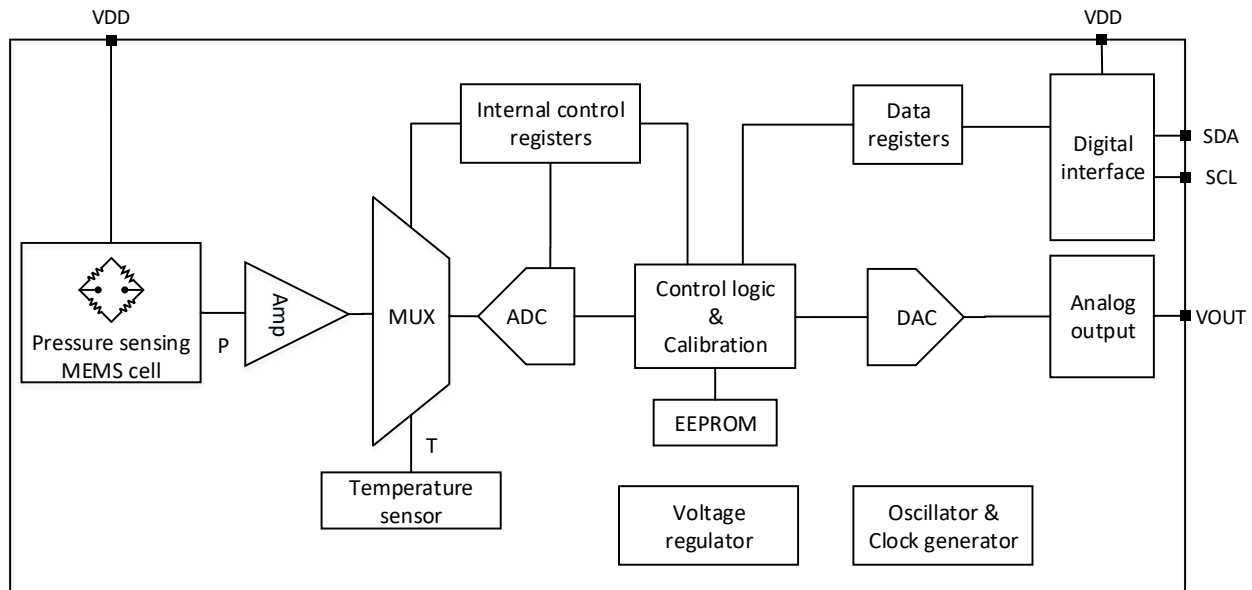

Figure 1: Block diagram

MEMS based piezo-resistors embedded on a suspended silicon membrane is the primary sensing element of the device. The piezo-resistors, connected in a Wheatstone bridge configuration produce analog output voltage proportional to the applied pressure.

Analog output is converted to the digital values through delta-sigma analog-to-digital converter (ADC). The ASIC embeds a high-resolution temperature sensor which is used for internal compensation of the pressure signal.

Each sensor is calibrated at three temperature and three pressure points. The trimming parameters and calibration coefficients (stored in the on-chip EEPROM) are used for the digital signal correction. The digital pressure values are available for the user to read via digital I<sup>2</sup>C interface.

Additionally, the sensors also provide optional digital temperature values for the temperature measurements via embedded temperature sensor.

Pressure values are also available as an analog voltage output. 11-bit digital to analog converter (DAC) embedded in the ASIC provides a calibrated analog voltage output through the VOUT pin.

## 2 Sensor specifications

### 2.1 General information

Parameter	Value
Operating temperature	-25 °C up to +85 °C
Compensated temperature range <sup>1</sup>	0 °C to 70 °C
Storage conditions	< 40 °C; < 90% RH
Communication interface	I <sup>2</sup> C, analog
Moisture sensitivity level (MSL)	1
Electrostatic discharge protection (HBM)	2 kV

Table 2: General information

### 2.2 Media compatibility

Port	Information
High pressure port <sup>2</sup>	Dry and non-corrosive gases compatible with silicon, RTV, ceramics Al <sub>2</sub> O <sub>3</sub> , Pyrex and LCP plastics
Low pressure port	Dry and non-corrosive gases compatible with silicon, RTV, ceramics Al <sub>2</sub> O <sub>3</sub> , Pyrex, epoxy and FR4

Table 3: Media compatibility

<sup>1</sup>The sensor output will be within the specified performance limits in this temperature range.

<sup>2</sup>Refer to figure 11 and figure 12 for port identification.

### 2.3 Absolute maximum ratings

Absolute maximum ratings are the limits, the device will withstand without permanent damage.

Parameter	Symbol	Part number	Value		Unit
			Min	Max	
Input voltage <i>VDD</i> pin	$V_{DD\_MAX}$	25131308xxxxx	-0.3	6.5	V
Input voltage <i>SDA</i> , <i>SCL</i> pins	$V_{IN\_MAX}$	25131308xxxxx	-0.3	5.5	V
Differential over pressure <sup>3</sup>	$P_{MAX}$	2513130810001		10	kPa
		2513130810101			
		2513130810102			
		2513130810201		100	
		2513130810301		300	
		2513130810401		2500	
		2513130810402			
2513130815401					
Differential burst pressure <sup>4</sup>	$P_{BURST}$	2513130810001		10	kPa
		2513130810101			
		2513130810102			
		2513130810201		150	
		2513130810301		500	
		2513130810401		2500	
		2513130810402			
2513130815401					

Table 4: Absolute maximum ratings



The device is susceptible to be damaged by electrostatic discharge (ESD). Always use proper ESD precautions when handling. Improper handling of the device can cause performance degradation or permanent damage.

<sup>3</sup>This is the pressure that may be applied to the sensor without causing damage to the sensing element. However, exposure to higher pressure may cause permanent damage to the sensor.

<sup>4</sup>This is the pressure that may be applied to the sensor without causing leakage and permanent damage to the sensing element.

## 2.4 Pressure sensor specifications

Unless otherwise stated, all the specified values were measured under the following condition:  
T = 25 °C.

### 2.4.1 Common paramters

Following pressure sensor parameters are applicable to part number.: 25131308xxxxx

Parameter	Symbol	Test conditions	Value			Unit
			Min	Typ	Max	
Nonlinearity <sup>4</sup>	ACC <sub>P_NL</sub>		-0.3	±0.1	0.3	%FSS
Resolution (ADC)	RES <sub>P</sub>			15		bit
Resolution (DAC)	RES <sub>P_DAC</sub>			11		bit
Response time	t <sub>RESP</sub>			2.2		ms

Table 5: Pressure sensor specifications (part nr.: 25131308xxx01)



Full Scale Span (FSS) is the algebraic difference between the sensor output at the maximum and minimum pressure of the measurement range (P<sub>RANGE</sub>).

<sup>4</sup>Nonlinearity is the maximum deviation of the sensor output from the straight line fit (BFSL) across the entire pressure measurement.

## 2.4.2 Part number specific parameters: 5V devices

Unless otherwise stated, all the specified values were measured under the following condition:  
 T = 25 °C and VDD = 5V

### Part number: 2513130810001

Parameter	Symbol	Test conditions	Value			Unit
			Min	Typ	Max	
Measurement range	P <sub>RANGE</sub>		-0.1		0.1	kPa
Absolute accuracy <sup>5</sup>	ACC <sub>P_ABS</sub>	T = 25 °C	-4	±2	4	%FSS
Total accuracy <sup>6</sup>	ACC <sub>P_TOT</sub>	T = 0 to 70 °C	-5	±2.5	5	%FSS
Sensitivity (digital)	SEN <sub>P</sub>			7.63 × 10 <sup>-6</sup>		kPa/digit
Sensitivity (analog)	SEN <sub>P_AN</sub>			0.05		kPa/ V
Repeatability <sup>7</sup>	ACC <sub>P_REP</sub>			±0.1		%FSS
Long term drift	ACC <sub>P_DRIFT</sub>			±0.5		%FSS

Table 6: Pressure sensor specifications (part nr.: 2513130810001)

### Part number: 2513130810101

Parameter	Symbol	Test conditions	Value			Unit
			Min	Typ	Max	
Measurement range	P <sub>RANGE</sub>		-1		1	kPa
Absolute accuracy <sup>5</sup>	ACC <sub>P_ABS</sub>	T = 25 °C	-1	±0.5	1	%FSS
Total accuracy <sup>6</sup>	ACC <sub>P_TOT</sub>	T = 0 to 70 °C	-1.25	±0.75	1.25	%FSS
Sensitivity (digital)	SEN <sub>P</sub>			7.63 × 10 <sup>-5</sup>		kPa/digit
Sensitivity (analog)	SEN <sub>P_AN</sub>			0.5		kPa/ V
Repeatability <sup>7</sup>	ACC <sub>P_REP</sub>			±0.05		%FSS
Long term drift	ACC <sub>P_DRIFT</sub>			±0.1		%FSS

Table 7: Pressure sensor specifications (part nr.: 2513130810101)

<sup>5</sup>Absolute accuracy includes effects of non-linearity, pressure hysteresis, offset, span and repeatability at room temperature.

<sup>6</sup>Total accuracy includes all effects of offset, non-linearity, pressure hysteresis, span, repeatability and thermal effects between the compensated temperature range 0 °C and 70 °C.

<sup>7</sup>Repeatability is the typical deviation of the sensor output after 10 pressure cycles.

**Part number: 2513130810201**

Parameter	Symbol	Test conditions	Value			Unit
			Min	Typ	Max	
Measurement range	P <sub>RANGE</sub>		-10		10	kPa
Absolute accuracy <sup>5</sup>	ACC <sub>P_ABS</sub>	T = 25 °C	-1	±0.5	1	%FSS
Total accuracy <sup>6</sup>	ACC <sub>P_TOT</sub>	T = 0 to 70 °C	-1.25	±0.75	1.25	%FSS
Sensitivity (digital)	SEN <sub>P</sub>			7.63 × 10 <sup>-4</sup>		kPa/digit
Sensitivity (analog)	SEN <sub>P_AN</sub>			5		kPa/ V
Repeatability <sup>7</sup>	ACC <sub>P_REP</sub>			±0.05		%FSS
Long term drift	ACC <sub>P_DRIFT</sub>			±0.1		%FSS

Table 8: Pressure sensor specifications (part nr.: 2513130810201)

**Part number: 2513130810301**

Parameter	Symbol	Test conditions	Value			Unit
			Min	Typ	Max	
Measurement range	P <sub>RANGE</sub>		0		100	kPa
Absolute accuracy <sup>5</sup>	ACC <sub>P_ABS</sub>	T = 25 °C	-0.3	±0.1	0.3	%FSS
Total accuracy <sup>6</sup>	ACC <sub>P_TOT</sub>	T = 0 to 70 °C	-0.5	±0.25	0.5	%FSS
Sensitivity (digital)	SEN <sub>P</sub>			3.815 × 10 <sup>-3</sup>		kPa/digit
Sensitivity (analog)	SEN <sub>P_AN</sub>			25		kPa/ V
Repeatability <sup>7</sup>	ACC <sub>P_REP</sub>			±0.01		%FSS
Long term drift	ACC <sub>P_DRIFT</sub>			±0.05		%FSS

Table 9: Pressure sensor specifications (part nr.: 2513130810301)

<sup>5</sup>Absolute accuracy includes effects of non-linearity, pressure hysteresis, offset, span and repeatability at room temperature.

<sup>6</sup>Total accuracy includes all effects of offset, non-linearity, pressure hysteresis, span, repeatability and thermal effects between the compensated temperature range 0 °C and 70 °C.

<sup>7</sup>Repeatability is the typical deviation of the sensor output after 10 pressure cycles.

**Part number: 2513130810401**

Parameter	Symbol	Test conditions	Value			Unit
			Min	Typ	Max	
Measurement range	P <sub>RANGE</sub>		-100		1000	kPa
Absolute accuracy <sup>5</sup>	ACC <sub>P_ABS</sub>	T = 25 °C	-0.3	±0.1	0.3	%FSS
Total accuracy <sup>6</sup>	ACC <sub>P_TOT</sub>	T = 0 to 70 °C	-0.5	±0.25	0.5	%FSS
Sensitivity (digital)	SEN <sub>P</sub>			4.196 × 10 <sup>-2</sup>		kPa/digit
Sensitivity (analog)	SEN <sub>P_AN</sub>			275		kPa/ V
Repeatability <sup>7</sup>	ACC <sub>P_REP</sub>			±0.01		%FSS
Long term drift	ACC <sub>P_DRIFT</sub>			±0.05		%FSS

Table 10: Pressure sensor specifications (Part nr.: 2513130810401)

**Part number: 2513130815401**

Parameter	Symbol	Test conditions	Value			Unit
			Min	Typ	Max	
Measurement range	P <sub>RANGE</sub>		0		1500	kPa
Absolute accuracy <sup>5</sup>	ACC <sub>P_ABS</sub>	T = 25 °C	-0.3	±0.1	0.3	%FSS
Total accuracy <sup>6</sup>	ACC <sub>P_TOT</sub>	T = 0 to 70 °C	-0.5	±0.25	0.5	%FSS
Sensitivity (digital)	SEN <sub>P</sub>			5.722 × 10 <sup>-2</sup>		kPa/digit
Sensitivity (analog)	SEN <sub>P_AN</sub>			375		kPa/ V
Repeatability <sup>7</sup>	ACC <sub>P_REP</sub>			±0.01		%FSS
Long term drift	ACC <sub>P_DRIFT</sub>			±0.05		%FSS

Table 11: Pressure sensor specifications (Part nr.: 2513130815401)

<sup>5</sup>Absolute accuracy includes effects of non-linearity, pressure hysteresis, offset, span and repeatability at room temperature.

<sup>6</sup>Total accuracy includes all effects of offset, non-linearity, pressure hysteresis, span, repeatability and thermal effects between the compensated temperature range 0 °C and 70 °C.

<sup>7</sup>Repeatability is the typical deviation of the sensor output after 10 pressure cycles.

### 2.4.3 Part number specific parameters: 3.3V devices

Unless otherwise stated, all the specified values were measured under the following condition:  
T = 25 °C and VDD = 3.3V

#### Part number: 2513130810102

Parameter	Symbol	Test conditions	Value			Unit
			Min	Typ	Max	
Measurement range	P <sub>RANGE</sub>		-1		1	kPa
Absolute accuracy <sup>5</sup>	ACC <sub>P_ABS</sub>	T = 25 °C	-1	±0.5	1	%FSS
Total accuracy <sup>6</sup>	ACC <sub>P_TOT</sub>	T = 0 to 70 °C	-1.25	±0.75	1.25	%FSS
Sensitivity (digital)	SEN <sub>P</sub>			7.63 × 10 <sup>-5</sup>		kPa/digit
Sensitivity (analog)	SEN <sub>P_AN</sub>			0.757		kPa/ V
Repeatability <sup>7</sup>	ACC <sub>P_REP</sub>			±0.05		%FSS
Long term drift	ACC <sub>P_DRIFT</sub>			±0.1		%FSS

Table 12: Pressure sensor specifications (part nr.: 2513130810102)

#### Part number: 2513130810402

Parameter	Symbol	Test conditions	Value			Unit
			Min	Typ	Max	
Measurement range	P <sub>RANGE</sub>		-100		1000	kPa
Absolute accuracy <sup>5</sup>	ACC <sub>P_ABS</sub>	T = 25 °C	-0.3	±0.1	0.3	%FSS
Total accuracy <sup>6</sup>	ACC <sub>P_TOT</sub>	T = 0 to 70 °C	-0.5	±0.25	0.5	%FSS
Sensitivity (digital)	SEN <sub>P</sub>			4.196 × 10 <sup>-2</sup>		kPa/digit
Sensitivity (analog)	SEN <sub>P_AN</sub>			416.66		kPa/ V
Repeatability <sup>7</sup>	ACC <sub>P_REP</sub>			±0.01		%FSS
Long term drift	ACC <sub>P_DRIFT</sub>			±0.05		%FSS

Table 13: Pressure sensor specifications (Part nr.: 2513130810402)

<sup>5</sup>Absolute accuracy includes effects of non-linearity, pressure hysteresis, offset, span and repeatability at room temperature.

<sup>6</sup>Total accuracy includes all effects of offset, non-linearity, pressure hysteresis, span, repeatability and thermal effects between the compensated temperature range 0 °C and 70 °C.

<sup>7</sup>Repeatability is the typical deviation of the sensor output after 10 pressure cycles.



## 2.5 Temperature sensor specifications

Unless otherwise stated, all the specified values were measured under the following condition:  
 $T = 25\text{ °C}$ .

Parameter	Symbol	Test conditions	Value			Unit
			Min	Typ	Max	
Measurement range	$T_{\text{RANGE}}$		0		70	°C
Resolution	$T_{\text{RES}}$			15		bits
Sensitivity	$SEN_T$			$4.272 \times 10^{-3}$		°C/digit

Table 14: Temperature sensor specifications

## 2.6 Electrical specifications

Unless otherwise stated, all the specified values were measured under the following conditions:  
 $T = 25\text{ °C}$ .

Parameter	Symbol	Test conditions	Value			Unit
			Min	Typ	Max	
Operating supply voltage	$V_{\text{DD}}$	3.3V device	3.0	3.3	3.6	V
		5 V device	4.75	5	5.25	V
Current consumption	$I_{\text{DD}}$			4	6.5	mA
Output current analog pin	$I_{\text{OUT\_A}}$				1	mA
Digital input voltage-high-level	$V_{\text{IH}}$		$0.7 * V_{\text{DD}}$			V
Digital input voltage-low-level	$V_{\text{IL}}$				$0.3 * V_{\text{DD}}$	V
Digital output voltage-high-level	$V_{\text{IH}}$		$0.9 * V_{\text{DD}}$			V
Digital output voltage-low-level	$V_{\text{IL}}$				$0.1 * V_{\text{DD}}$	V

Table 15: Electrical specifications

### 3 Pinning information

#### 3.1 Pin configuration

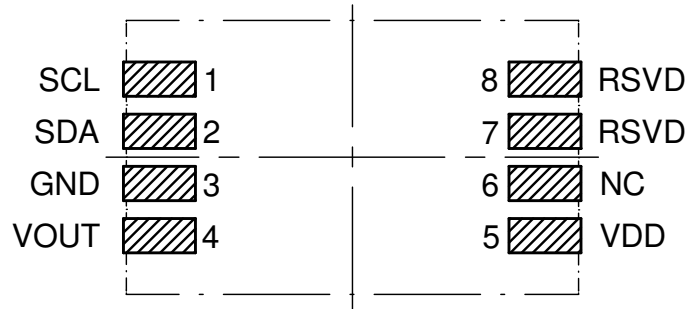

Figure 2: Pin specifications - vertical nozzles (top view)

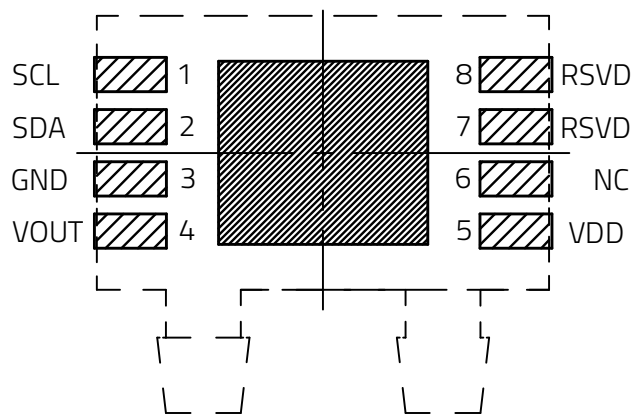

Figure 3: Pin specifications- horizontal nozzles (top view)

## 3.2 Pin description

Pin No.	Name	Function	Input/output	Comments
1	<i>SCL</i>	I <sup>2</sup> C serial clock	Input	
2	<i>SDA</i>	I <sup>2</sup> C serial data	Input/Output	
3	<i>GND</i>	Negative supply voltage	Supply	
4	<i>VOUT</i>	Analog output	Output	
5	<i>VDD</i>	Positive supply voltage	Supply	
6	<i>NC</i>	No connection		
7	<i>RSVD</i>	Reserved		Do not connect
8	<i>RSVD</i>	Reserved		Do not connect

Table 16: Pin description

## 4 Digital interface

The sensor supports standard I<sup>2</sup>C (Inter-IC) bus protocol. I<sup>2</sup>C is a serial 8-bit protocol with two-wire interface that supports communication between different ICs, for example, between microcontrollers and other peripheral devices<sup>1</sup>.

### 4.1 General characteristics

A serial data line (*SDA*) and a serial clock line (*SCL*) are required for the communication between the devices connected via I<sup>2</sup>C bus. Both *SDA* and *SCL* lines are bidirectional. The output stages of devices connected to the bus must have an open-drain or open-collector. Hence, the *SDA* and *SCL* lines are connected to a positive supply voltage via pull-up resistors. In I<sup>2</sup>C protocol, the communication is realized through master-slave principle. A master device generates the clock pulse, a start command and a stop command for the data transfer. Each connected device on the bus is addressable via a unique address. Master and slave can act as a transmitter (master-transmitter or slave transmitter) or a receiver (master receiver or slave receiver) depending upon whether the data needs to be sent or received.



This sensor behaves like a slave device on the I<sup>2</sup>C bus.

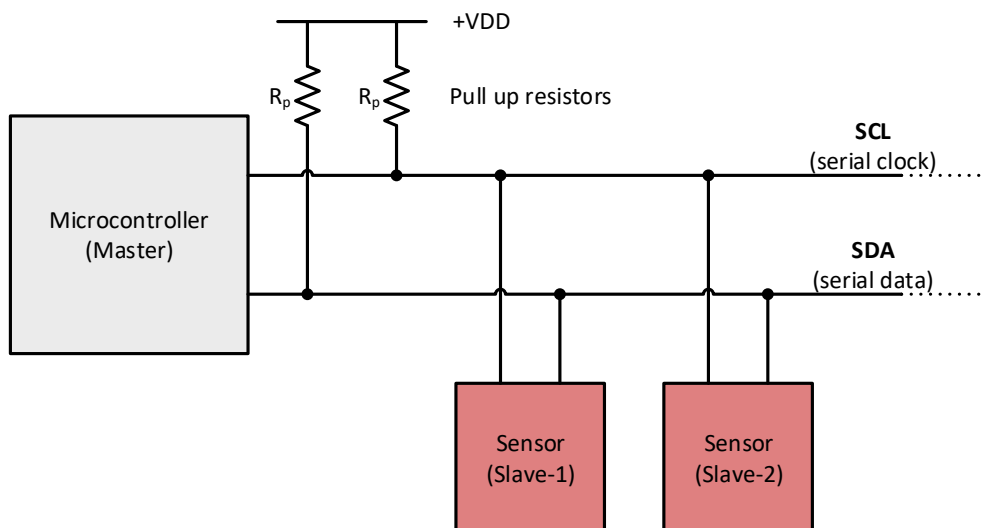

Figure 4: Master-slave concept

<sup>1</sup>Further information about the I<sup>2</sup>C interface can be found at <https://www.nxp.com/docs/en/user-guide/UM10204.pdf>.

## 4.2 SDA and SCL logic levels

The positive supply voltage to which *SDA* and *SCL* lines are pulled up (through pull-up resistors), in turn determines the high level input for the slave devices. Input reference levels for this sensor are set as  $0.7 \cdot V_{DD}$  (for logic high) and  $0.3 \cdot V_{DD}$  (for logic low). See figure 5.

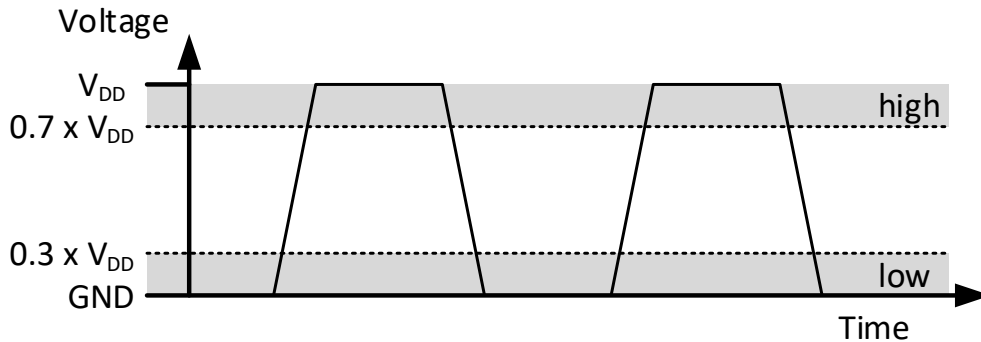

Figure 5: *SDA* and *SCL* logic levels

## 4.3 Communication phase

### 4.3.1 Idle state

During the idle state, the bus is free and both *SDA* and *SCL* lines are in logic high '1' state.

### 4.3.2 START (S) and STOP (P) condition

Data transfer on the bus starts with a START command, which is generated by the master. A start condition is defined as a high-to-low transition on the *SDA* line while the *SCL* line is held high. The bus is considered busy after the start condition.

Data transfer on the bus is terminated with a STOP command, which is also generated by the master. A low-to-high transition on the *SDA* line, while the *SCL* line being high is defined as a STOP condition. After the stop condition, the bus is considered free again and is in idle state.

Figure 6 shows the I<sup>2</sup>C bus START and STOP conditions.

Master can also send a REPEATED START (SR) command instead of STOP command. REPEATED START condition is the same as the START condition.

### 4.3.3 Data validity

After the start condition, one data bit is transferred with each clock pulse. The transmitted data is only valid when the *SDA* line data is stable (high or low) during the high period of the clock pulse. High or low state of the data line can only change when clock pulse is in low state.

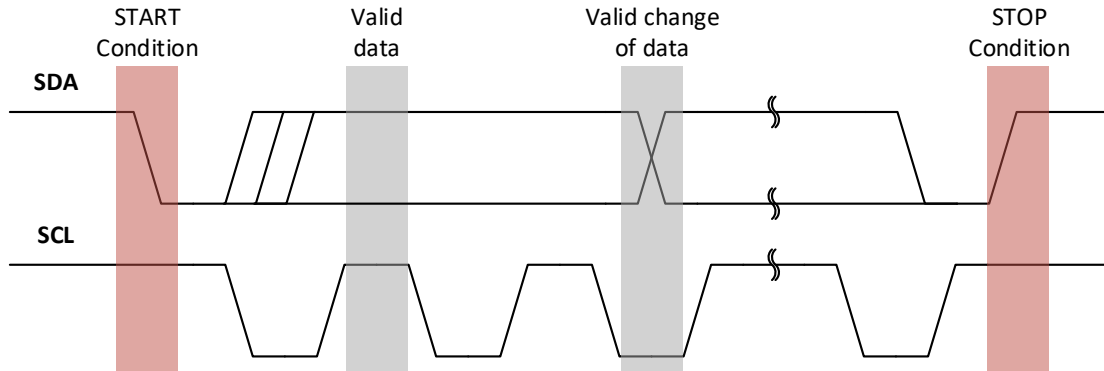

Figure 6: Data validity, START and STOP condition

### 4.3.4 Byte format

Data transmission on the *SDA* line is always done in bytes, with each byte being 8-bits long. Data is transferred with the most significant bit (MSB) followed by other bits.

If the slave cannot receive or transmit another complete byte of data, it can force the master into a wait state by holding *SCL* low. Data transfer continues when the slave is ready which is indicated by releasing the *SCL* line.

### 4.3.5 Acknowledge (ACK) and No-Acknowledge (NACK)

Each byte sent on the data line must be followed by an Acknowledge bit. The receiver (master or slave) generates an Acknowledge signal to indicate that the data byte was received successfully and another data byte could be sent.

After one byte is transmitted, the master generates an additional Acknowledge clock pulse to continue the data transfer. The transmitter releases the *SDA* line during this clock pulse so that the receiver can pull the *SDA* line to low state in such a way that the *SDA* line remains stable low during the entire high period of the clock pulse. This is considered as an Acknowledge signal.

In case the receiver does not want to receive any further byte, it does not pull down the *SDA* line and it remains in stable high state during the entire clock pulse. This is considered as a No-Acknowledge signal and the master can generate either a stop condition to terminate the data transfer or a repeated start condition to initiate a new data transfer.

**4.3.6 Slave address for the sensor**

The slave address is transmitted after the start condition. Each device on the I<sup>2</sup>C bus has a unique address. Master selects the slave by sending corresponding address after the start condition. A slave address is 7 bits long followed by a Read/Write bit.

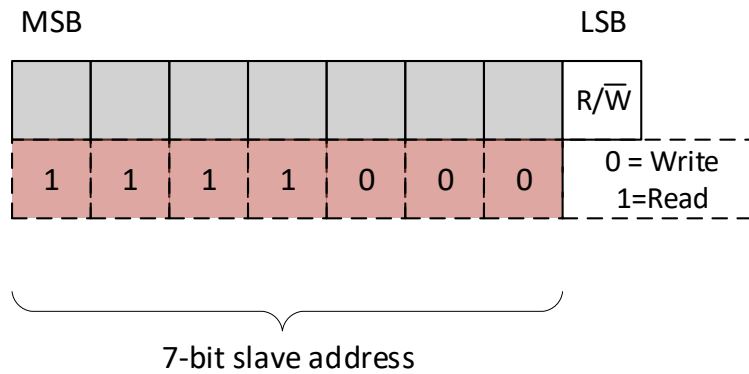

Figure 7: Slave address format



7-bit slave address of this device is 1111000b (0x78).

The R/W bit determines the data direction. A '0' indicates a write operation (transmission from master to slave) and a '1' indicates a read operation (request data from slave).



This device is configured to work as a slave-transmitter, meaning it can only respond to the data request made by master (R/W bit = 1).

### 4.3.7 Read operation

Once the slave-address and data direction bit is sent, the slave acknowledges the master. The slave can then transmit multiple number of data bytes. Each transmitted data byte is followed by an Acknowledgement from the master. If the master no longer wants to receive further data from the slave, it would send No-Acknowledge (NACK). Afterwards, Master can send a STOP condition to terminate the data transfer.

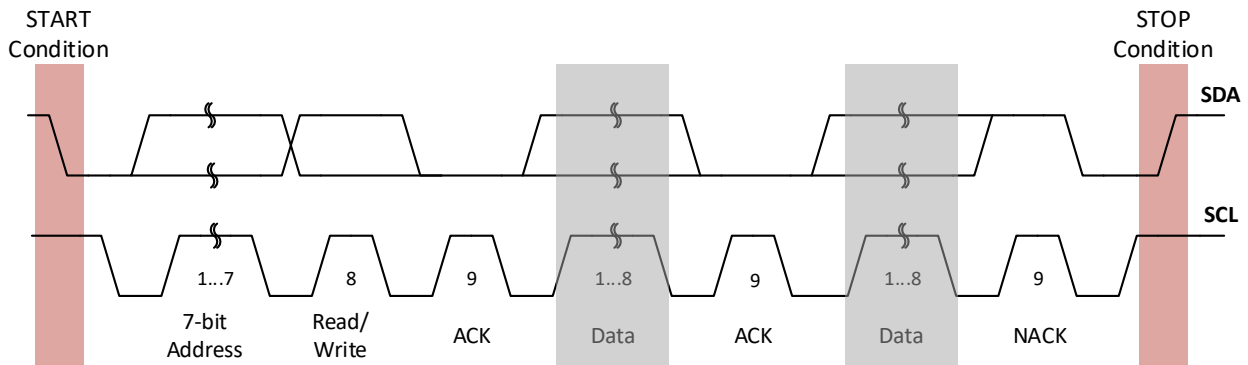

Figure 8: Complete data transfer



## 4.4 I<sup>2</sup>C timing parameters

Parameter	Symbol	Min	Max	Unit
<i>SCL</i> clock frequency	$f_{SCL}$	100	400	kHz
LOW period for <i>SCL</i> clock	$t_{LOW\_SCL}$	1.3		$\mu$ s
HIGH period for <i>SCL</i> clock	$t_{HIGH\_SCL}$	0.6		$\mu$ s
Hold time for START condition	$t_{HD\_S}$	0.8		$\mu$ s
Setup time for (repeated) START condition	$f_{SCL}$	1		$\mu$ s
<i>SDA</i> setup time	$t_{SU\_SDA}$	0.2		$\mu$ s
<i>SDA</i> data hold time	$t_{HD\_SDA}$	0		$\mu$ s
Setup time for STOP condition	$t_{SU\_P}$	0.6		$\mu$ s
Bus free time between STOP and START condition	$t_{BUF}$	1.3		$\mu$ s

Table 17: I<sup>2</sup>C timing parameters

## 5 Application circuit

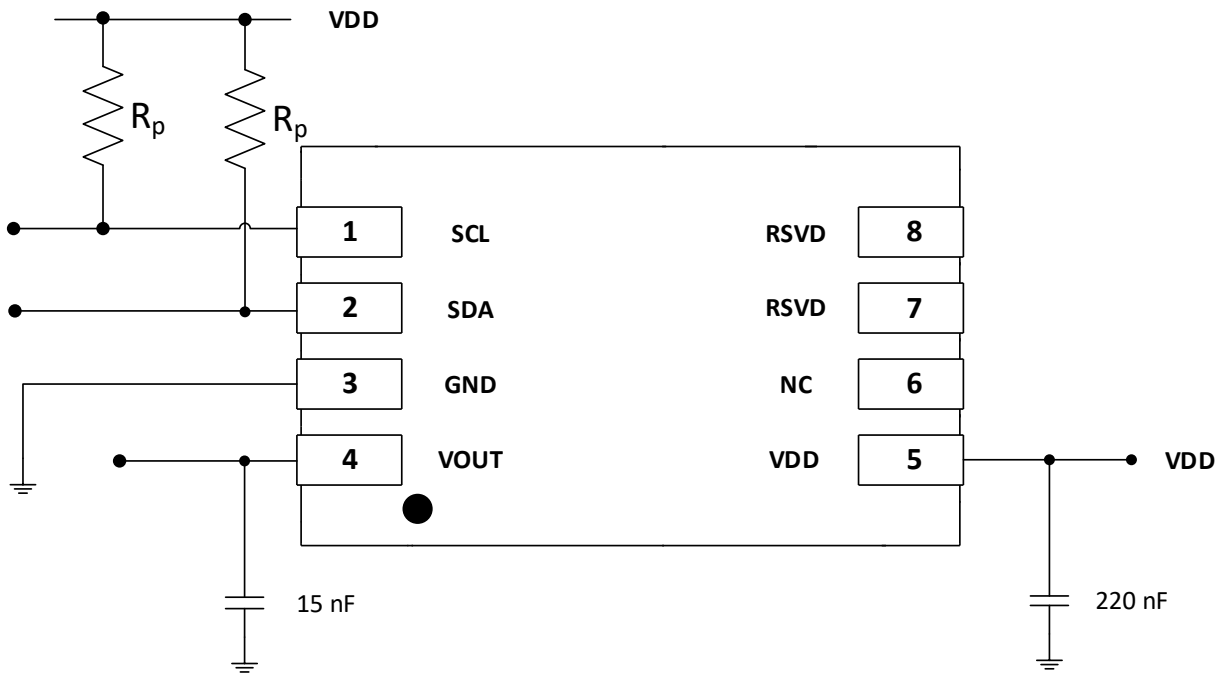

Figure 9: Application circuit with I<sup>2</sup>C interface (top view)

*VDD* pin is the central supply pin for the MEMS cell and internal circuits. In order to prevent ripple from the power supply, a decoupling capacitor of 220 nF must be placed as close to the *VDD* pad of the sensor as possible. Further, a decoupling capacitor of 15 nF should be placed between *VOUT* and ground.



If both digital I<sup>2</sup>C and analog interfaces are used simultaneously, it is recommended to route these lines as far from each other as possible.

*SCL* and *SDA* must be connected to *VDD* through the pull-up resistors. Proper value of the pull-up resistors must be chosen depending on the I<sup>2</sup>C bus speed and load. The sensor does not have internal pull-up resistors.

Avoid routing of the *VDD*, *SDA/SCL* and *GND* lines underneath the sensor (see section 9.3 for further information).

## 6 Reading digital output data

The sensor generates fully calibrated and temperature compensated digital pressure values which is available for the user to read through host controller. Sensor must be interfaced to the host controller via I<sup>2</sup>C interface. For details about I<sup>2</sup>C interface, refer to chapter 4. Once the host controller (master) sends the start condition and data direction bit as READ (R/W=1), the sensor starts transmitting the pressure (2 bytes) and temperature (2 bytes) data. Pressure data is transmitted in 1<sup>st</sup> and 2<sup>nd</sup> bytes as a 15 bit information. Temperature data is then transmitted in the following two bytes (3<sup>rd</sup> and 4<sup>th</sup>) as a 15 bit information. New Pressure and temperature data is generated every 2.2 ms. The sensor will continue to send the alternating pressure and temperature values as 15-bit information until it is deactivated by a STOP condition from the host controller.

Figure 10 shows the reading operation the master and the slave device (sensor).

**Host controller reading multiple data bytes from the sensor (slave)**

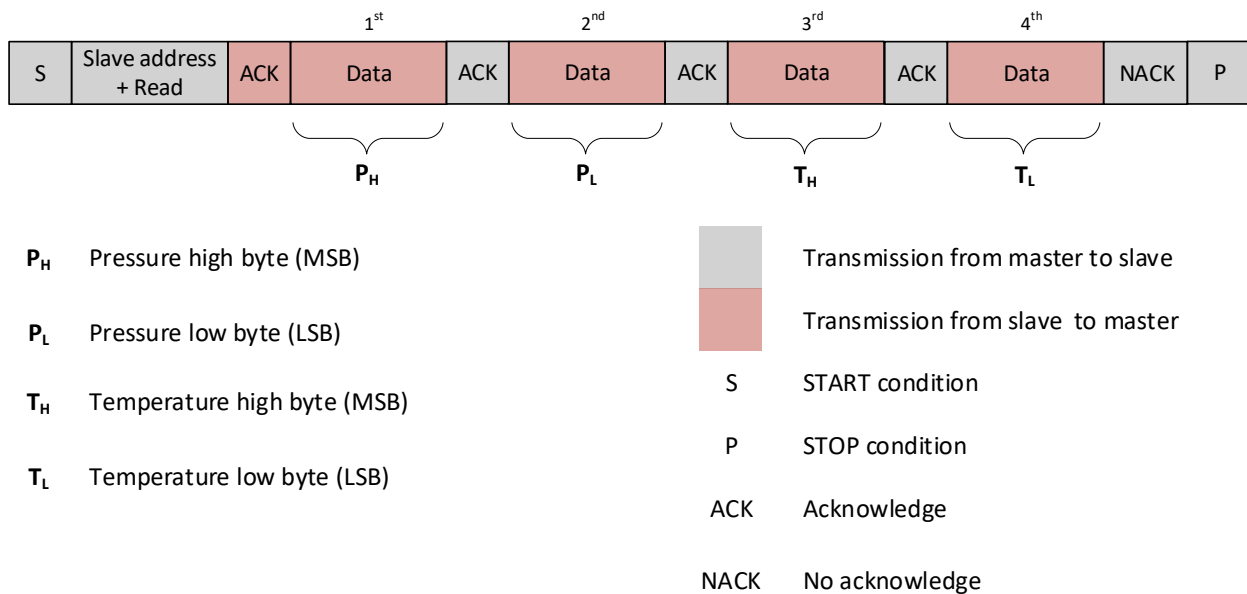

Figure 10: Reading output data with I<sup>2</sup>C interface



The sensor response time is about 2.2 ms, meaning it sends a new set of pressure (2 bytes) and temperature (2 bytes) data every 2.2 ms. With the I<sup>2</sup>C clock frequency of 400 kHz, the exchange of the 4 data bytes containing the current pressure and temperature values takes about 80 μs.

## 6.1 Pressure output: digital

**Part numbers: 2513130810001, 2513130810101, 2513130810201, 2513130810102**

Parameter	Symbol	Value			Unit
		Min	Typ	Max	
Zero pressure offset	OUT <sub>OFF</sub>		16384		digits
Full scale span	FSS		26214		
Output at minimum pressure	OUT <sub>P_MIN</sub>		3277		
Output at maximum pressure	OUT <sub>P_MAX</sub>		29491		

Table 18: Digital pressure output: bidirectional

**Part numbers: 2513130810301, 2513130815401**

Parameter	Symbol	Value			Unit
		Min	Typ	Max	
Zero pressure offset	OUT <sub>OFF</sub>		3277		digits
Full scale span	FSS		26214		
Output at minimum pressure	OUT <sub>P_MIN</sub>		3277		
Output at maximum pressure	OUT <sub>P_MAX</sub>		29491		

Table 19: Digital pressure output: unidirectional

**Part numbers: 2513130810401 and 2513130810402**

Parameter	Symbol	Value			Unit
		Min	Typ	Max	
Zero pressure offset	OUT <sub>OFF</sub>		5660		digits
Full scale span	FSS		26214		
Output at minimum pressure	OUT <sub>P_MIN</sub>		3277		
Output at maximum pressure	OUT <sub>P_MAX</sub>		29491		

Table 20: Digital pressure output



Digital output is not ratiometric to the positive supply voltage  $VDD$  .

## 6.2 Temperature output: digital

Parameter	Symbol	Value			Unit
		Min	Typ	Max	
Output at minimum temperature	$OUT_{T\_MIN}$		8192		digits
Output at maximum temperature	$OUT_{T\_MAX}$		24576		

Table 21: Digital temperature output: all devices

### 6.3 Interpreting digital pressure values

First two bytes transmitted from the sensor consists of pressure data where the first byte being most significant byte (MSB) and the second byte being least significant byte (LSB). The complete 15-bit pressure value can be obtained by concatenating the two bytes of pressure data. Corresponding pressure in SI unit (Pa) can be obtained from the digital pressure values with the help of sensitivity parameter  $SEN_P$  (see section 2.4.2).

Step 1: Get two bytes of pressure data

1.  $P_H$
2.  $P_L$

Step 2: Concatenate two pressure data bytes to obtain complete 15-bit pressure value

$$P_{15bit} = P_H \& P_L$$

Step 3: Obtain pressure value in SI unit (Pa) with following formula

$$\text{Pressure [kPa]} = [(P_{15bit} - OUT_{P\_MIN}) \times SEN_P] + P_{MIN}$$

Where,

- $P_{15bit}$  = Digital pressure value obtained in step 2.
- $OUT_{P\_MIN}$  = Digital output at minimum pressure for the specific part number (see section: 6.1)
- $SEN_P$  = Sensitivity (digital) for specific part number (see section: 2.4.2)
- $P_{MIN}$  = Minimum pressure measurement range for specific part number (see section: 2.4.2)

#### Example:

Pressure data obtained from sensor 2513130810301 (pressure range: 0 to 100 kPa) are:

$$P_H = 0x16$$

$$P_L = 0x1C$$

Concatenating these 2 bytes (0x161C) to obtain 15-bit decimal value

$$P_{15bit}[\text{digit}] = 5660$$

For part number 25131308103,  $OUT_{P\_MIN} = 3277$  digits (see table:19),  $SEN_P = 3.815 \times 10^{-3}$  kPa/digits and  $P_{MIN} = 0$  kPa (see table:9).

$$P[\text{kPa}] = (5660-3277) [\text{digit}] \times 3.815 \times 10^{-3} [\text{kPa/digits}] = 9.09 \text{ kPa}$$

## 6.4 Interpreting digital temperature values

Following the pressure data, temperature data is transmitted as a 3rd and 4th byte. The complete 15-bit temperature value can be obtained by concatenating the two bytes of temperature data, where the 3rd byte being most significant byte (MSB) and the 4th byte being least significant byte (LSB) of the temperature value. Corresponding temperature in SI unit (°C) can be obtained from the digital temperature values with the help of sensitivity parameter  $SEN_T$  (see table 14).

Step 1: Get two bytes of temperature data

1.  $T_H$
2.  $T_L$

Step 2: Concatenate the two bytes to obtain complete 15-bit temperature value

$$T_{15bit} = T_H \& T_L$$

Step 3: Obtain temperature value in SI unit [°C] with following formula

$$\text{Temperature [°C]} = (T_{15bit} - OUT_{T\_MIN}) \times SEN_T$$

Where,

- $T_{15bit}$  = Digital temperature value obtained in step 2.
- $OUT_{T\_MIN}$  = Digital output at minimum temperature = 8192 [digit] (see table: 21)
- $SEN_T$  =  $4.272 \times 10^{-3}$  [°C/digit] (see table: 14)

### Example:

Temperature data obtained from sensor are:

$$T_H = 0x36$$

$$T_L = 0xC5$$

Concatenating these 2 bytes (0x36C5) to obtain 15-bit decimal value

$$T_{15bit}[\text{digit}] = 14021$$

$$T[\text{°C}] = (14021 - 8192)[\text{digit}] \times 4.272 \times 10^{-3} [\text{digit/°C}] = 24.90 \text{ °C}$$

## 7 Reading analog pressure data

The sensors also produce fully calibrated pressure values as a ratiometric analog voltage output, which can be read through *VOUT* pin of the sensor. Following section shows the typical analog voltage values for the sensors at  $V_{DD} = 5\text{ V}$  or  $V_{DD} = 3.3\text{ V}$ .



Analog output voltage is ratiometric<sup>1</sup> to the positive supply voltage *VDD*.

### 7.1 Analog pressure output: 5V devices

Part number: 2513130810001, 2513130810101, 2513130810201

Parameter	Symbol	Value			Unit
		Min	Typ	Max	
Zero pressure offset	OUT <sub>OFF</sub>		2.5		V
Full scale span	FSS		4		
Output at minimum pressure	OUT <sub>P_MIN</sub>		0.5		
Output at maximum pressure	OUT <sub>P_MAX</sub>		4.5		

Table 22: Analog pressure output

Part number: 2513130810301, 2513130815401

Parameter	Symbol	Value			Unit
		Min	Typ	Max	
Zero pressure offset	OUT <sub>OFF</sub>		0.5		V
Full scale span	FSS		4		
Output at minimum pressure	OUT <sub>P_MIN</sub>		0.5		
Output at maximum pressure	OUT <sub>P_MAX</sub>		4.5		

Table 23: Analog pressure output

<sup>1</sup>Ratiometric: Output signal changes in proportion to the change in supply voltage.



**Part number: 2513130810401**

Parameter	Symbol	Value			Unit
		Min	Typ	Max	
Zero pressure offset	OUT <sub>OFF</sub>		0.87		V
Full scale span	FSS		4		
Output at minimum pressure	OUT <sub>P_MIN</sub>		0.5		
Output at maximum pressure	OUT <sub>P_MAX</sub>		4.5		

Table 24: Analog pressure output

## 7.2 Analog pressure output: 3.3V devices

**Part number: 2513130810102**

Parameter	Symbol	Value			Unit
		Min	Typ	Max	
Zero pressure offset	OUT <sub>OFF</sub>		1.65		V
Full scale span	FSS		2.64		
Output at minimum pressure	OUT <sub>P_MIN</sub>		0.30		
Output at maximum pressure	OUT <sub>P_MAX</sub>		2.97		

Table 25: Analog pressure output

**Part number: 2513130810402**

Parameter	Symbol	Value			Unit
		Min	Typ	Max	
Zero pressure offset	OUT <sub>OFF</sub>		0.57		V
Full scale span	FSS		2.64		
Output at minimum pressure	OUT <sub>P_MIN</sub>		0.30		
Output at maximum pressure	OUT <sub>P_MAX</sub>		2.97		

Table 26: Analog pressure output

## 8 Look-up Table

Partnumber	Operating Voltage (V)	OUT <sub>P_MIN</sub> (digits)	SEN <sub>P</sub> (kPa/digit)	P <sub>MIN</sub> (kPa)
2513130810001	5V	3277	7.63 × 10 <sup>-6</sup>	-0.1
2513130810101	5V	3277	7.63 × 10 <sup>-5</sup>	-1
2513130810102	3.3V	3277	7.63 × 10 <sup>-5</sup>	-1
2513130810201	5V	3277	7.63 × 10 <sup>-4</sup>	-10
2513130810301	5V	3277	3.815 × 10 <sup>-3</sup>	0
2513130810401	5V	3277	4.196 × 10 <sup>-2</sup>	-100
2513130810402	3.3V	3277	4.196 × 10 <sup>-2</sup>	-100
2513130815401	5V	3277	5.722 × 10 <sup>-2</sup>	0

Table 27: look up table: Digital output

$$\text{Pressure [kPa]} = [(P_{15\text{bit}} - \text{OUT}_{P\_MIN}) \times \text{SEN}_P] + P_{MIN}$$

Partnumber	Operating Voltage (V)	OUT <sub>P_MIN</sub> (V)	SEN <sub>P</sub> (kPa/V)	P <sub>MIN</sub> (kPa)
2513130810001	5V	0.5	0.05	-0.1
2513130810101	5V	0.5	0.5	-1
2513130810102	3.3V	0.5	0.757	-1
2513130810201	5V	0.5	5	-10
2513130810301	5V	0.5	25	0
2513130810401	5V	0.5	275	-100
2513130810402	3.3V	0.5	416.66	-100
2513130815401	5V	0.5	375	0

Table 28: look up table: Analog output

$$\text{Pressure [kPa]} = [(P_{\text{voltage}} - \text{OUT}_{P\_MIN}) \times \text{SEN}_P] + P_{MIN}$$

## 9 Physical specifications

### 9.1 Sensor drawing: Vertical Nozzles

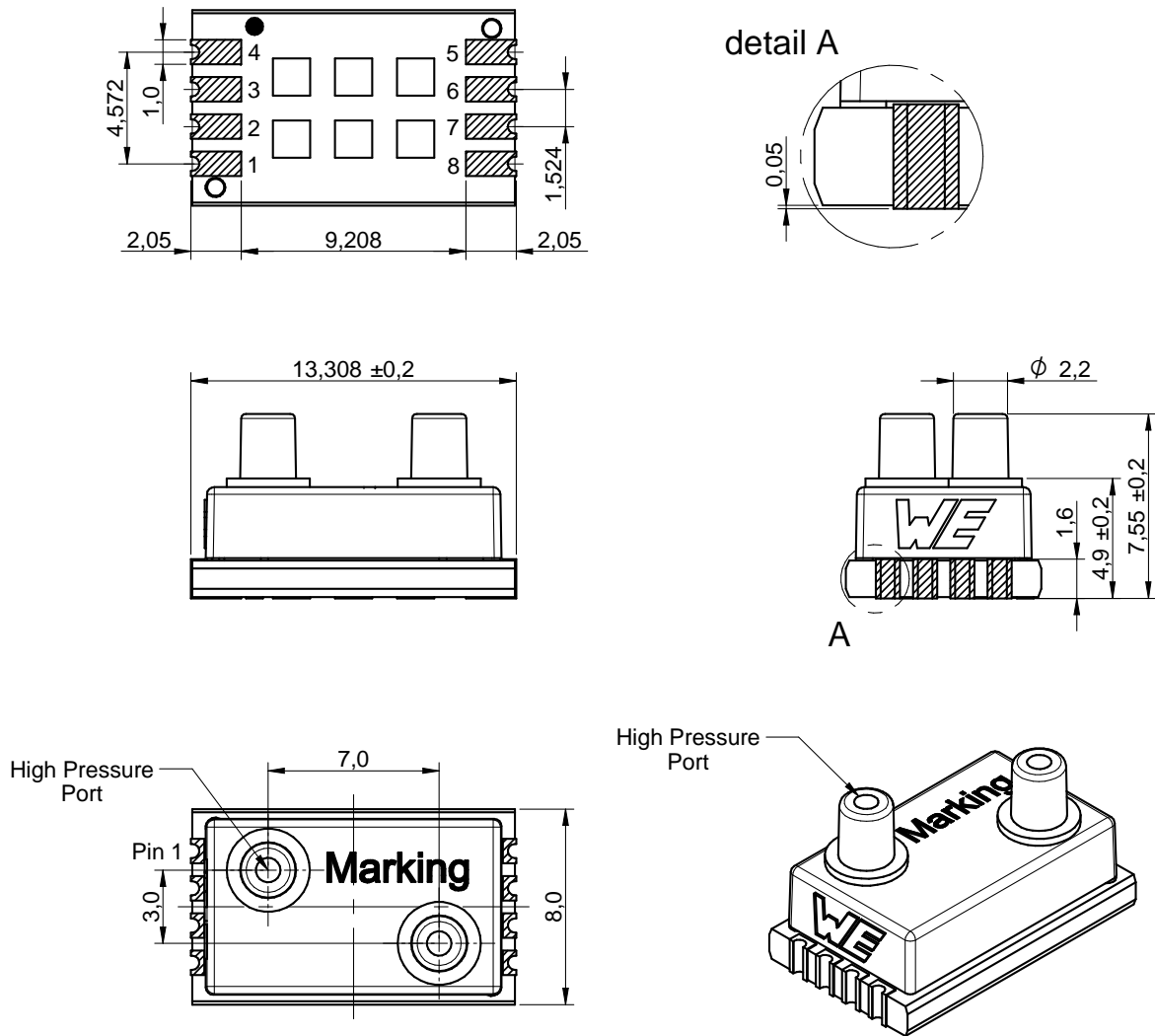

Figure 11: Sensor dimensions: Vertical nozzles [mm]

## 9.2 Sensor drawing: Horizontal-Barbed Nozzles

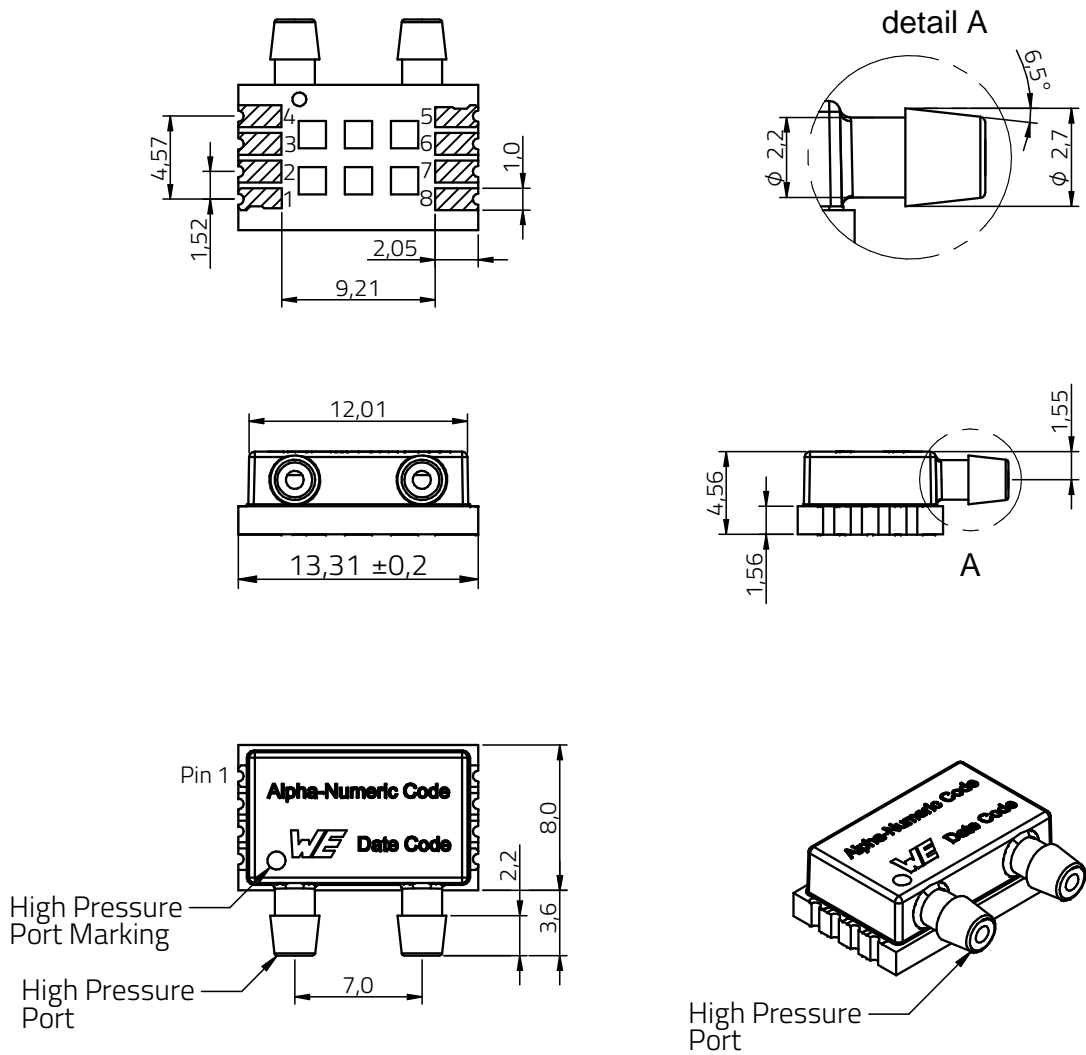

Figure 12: Sensor dimensions: Horizontal-barbed nozzles [mm]

### 9.3 Footprint

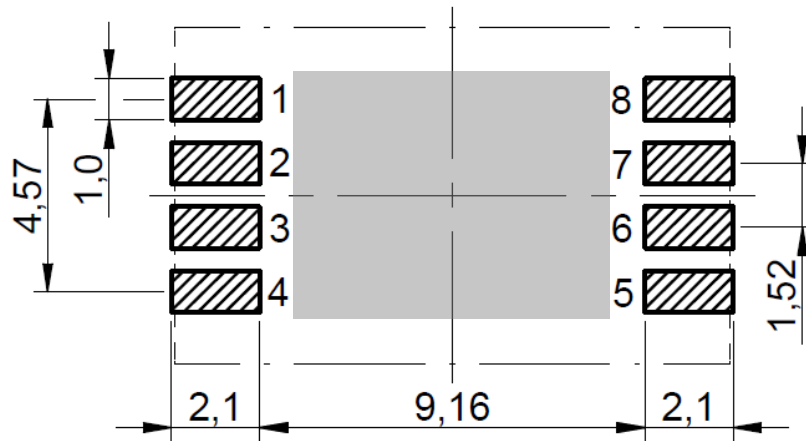

Figure 13: Recommended land pattern [mm] (top view)



Open traces, open wires or vias are not allowed in the centre area of the sensor (marked in grey in the figure 13)

## 9.4 Marking information

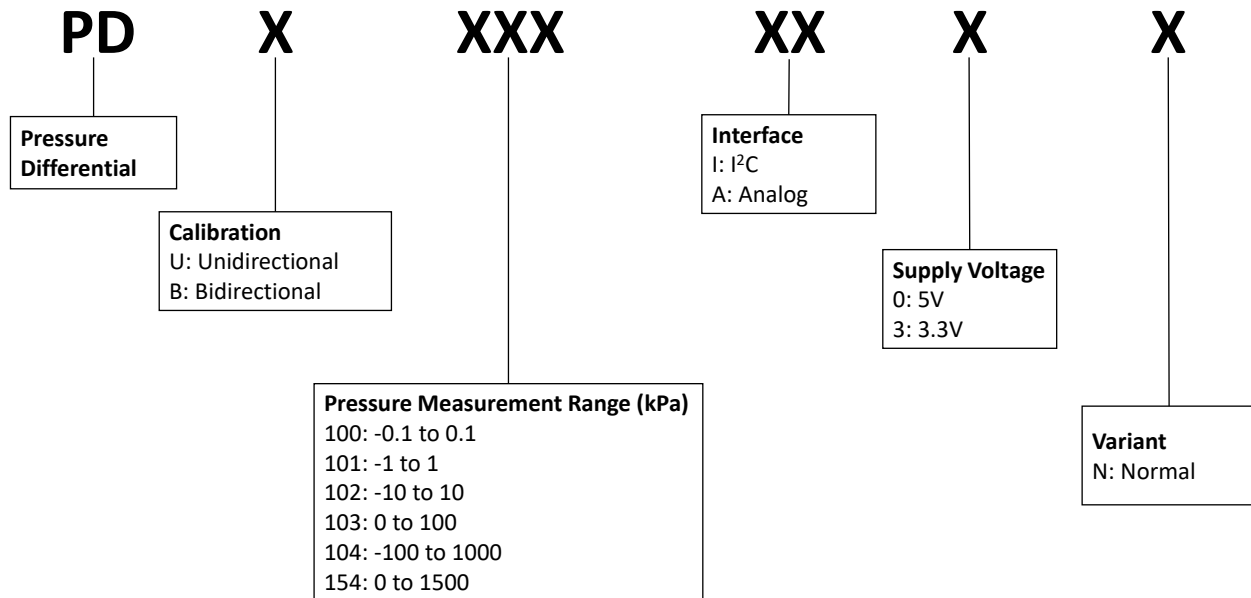

Figure 14: Marking information



Marking PDB101IA0N indicates a differential pressure sensor with measurement range from -1 to 1 kPa. The corresponding WE part number is 2513130810101.

## 10 Manufacturing information

### 10.1 Moisture sensitivity level

The sensor product is categorized as JEDEC Moisture Sensitivity Level 3 (MSL3), which requires special handling.

More information regarding the MSL requirements can be found in the IPC/JEDEC J-STD-020 standard on [www.jedec.org](http://www.jedec.org). More information about the handling, picking, shipping and the usage of moisture/re-flow and/or process sensitive products can be found in the IPC/JEDEC J-STD-033 standard on [www.jedec.org](http://www.jedec.org).

### 10.2 Reflow soldering

Attention must be paid on the thickness of the solder resist between the host PCB top side and the modules bottom side. Only lead-free assembly is recommended according to JEDEC J-STD020.

Profile feature		Value
Preheat temperature, min	$T_{S \text{ Min}}$	150 °C
Preheat temperature, max	$T_{S \text{ Max}}$	200 °C
Preheat time from $T_{S \text{ Min}}$ to $T_{S \text{ Max}}$	$t_S$	60 - 120 seconds
Ramp-up rate ( $T_L$ to $T_P$ )		3 °C / second max.
Liquidous temperature	$T_L$	217 °C
Time $t_L$ maintained above $T_L$	$t_L$	60 - 150 seconds
Peak package body temperature	$T_P$	see table below
Time within 5 °C of actual peak temperature	$t_P$	20 - 30 seconds
Ramp-down rate ( $T_P$ to $T_L$ )		6 °C / second max.
Time 20 °C to $T_P$		8 minutes max.

Table 29: Classification reflow soldering profile, Note: refer to IPC/JEDEC J-STD-020E

**\* In order to reduce residual stress on the sensor component, the recommended ramp-down temperature slope should be lower than 3 °C /s.**

Package thickness	Volume mm <sup>3</sup> <350	Volume mm <sup>3</sup> 350-2000	Volume mm <sup>3</sup> >2000
< 1.6 mm	260 °C	260 °C	260 °C
1.6 mm - 2.5 mm	260 °C	250 °C	245 °C
> 2.5 mm	250 °C	245 °C	245 °C

Table 30: Package classification reflow temperature, PB-free assembly, Note: refer to IPC/JEDEC J-STD-020E

It is recommended to solder the sensor on the last re-flow cycle of the PCB. For solder paste use a LFM-48W or Indium based SAC 305 alloy (Sn 96.5 / Ag 3.0 / Cu 0.5 / Indium 8.9HF / Type 3 / 89 %) type 3 or higher.

The reflow profile must be adjusted based on the thermal mass of the entire populated PCB, heat transfer efficiency of the reflow oven and the specific type of solder paste used. Based on the specific process and PCB layout the optimal soldering profile must be adjusted and verified. Other soldering methods (e.g. vapor phase) have not been verified and have to be validated by the customer at their own risk. Rework is not recommended.

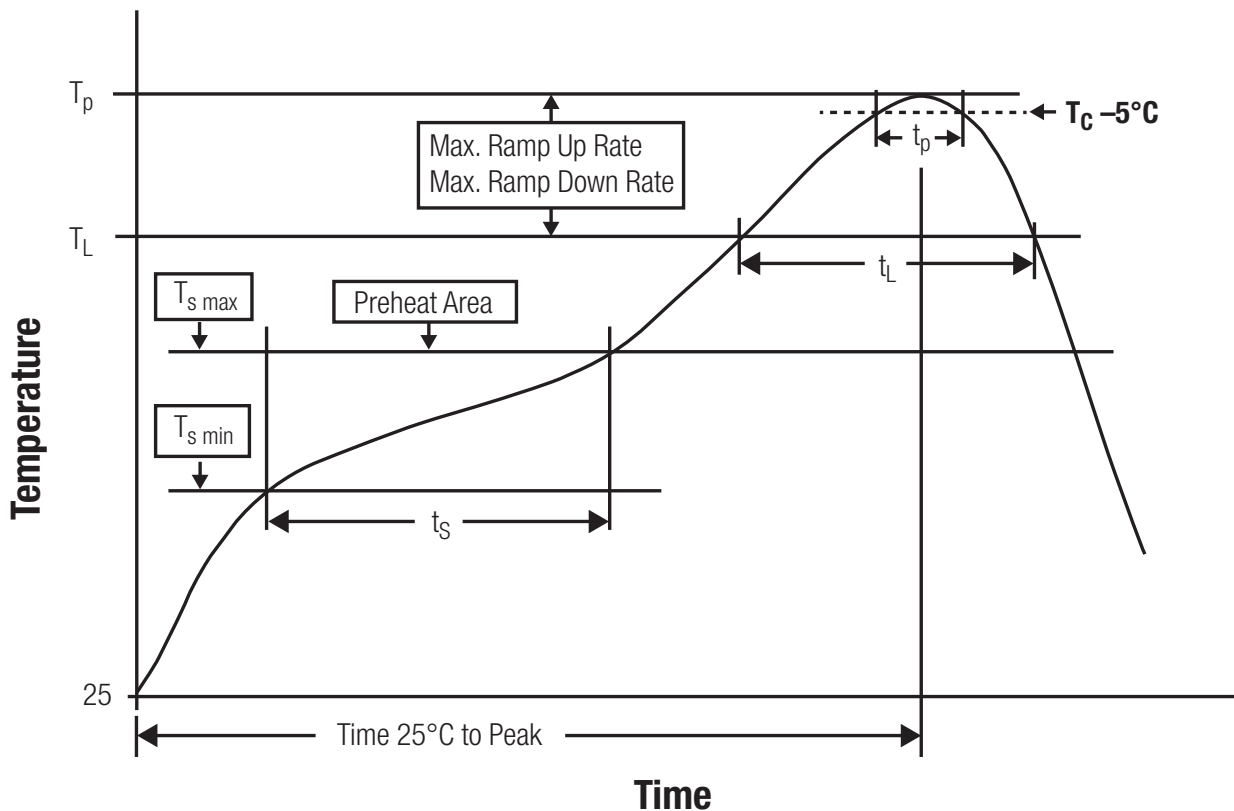

Figure 15: Reflow soldering profile

After reflow soldering, visually inspect the board to confirm proper alignment.

### 10.3 Cleaning and washing

- Do not clean the product. Any residue cannot be easily removed by washing. Use a "no clean" soldering paste and do not clean the board after soldering.
- Washing agents used during the production to clean the customer application might damage or change the characteristics of the component. Washing agents may have a negative effect on the long-term functionality of the product.



- Using a brush during the cleaning process may damage the component. Therefore, we do not recommend using a brush during the PCB cleaning process

## 10.4 Potting and coating

- Potting material might shrink or expand during and after hardening. This might apply mechanical stress on the components, which can influence the characteristics of the transfer function. In addition, potting material can close existing openings in the housing. This can lead to a malfunction of the component. Thus, potting is not recommended.
- Conformal coating may affect the product performance. We do not recommend coating the components.

## 10.5 Storage conditions

- A storage of Würth Elektronik eiSos products for longer than 12 months is not recommended. Within other effects, the terminals may suffer degradation, resulting in bad solderability. Therefore, all products shall be used within the period of 12 months based on the day of shipment.
- Do not expose the components to direct sunlight.
- The storage conditions in the original packaging are defined according to DIN EN 61760 - 2.
- For a moisture sensitive component, the storage condition in the original packaging is defined according to IPC/JEDEC-J-STD-033. It is also recommended to return the component to the original moisture proof bag and reseal the moisture proof bag again.

## 10.6 Handling

- Violation of the technical product specifications such as exceeding the nominal rated supply voltage, will void the warranty.
- Violation of the technical product specifications such as but not limited to exceeding the absolute maximum ratings will void the conformance to regulatory requirements.
- ESD prevention methods need to be followed for manual handling and processing by machinery.
- The edge castellation is designed and made for prototyping, i.e. hand soldering purposes only.
- The applicable country regulations and specific environmental regulations must be observed.
- Do not disassemble the product. Evidence of tampering will void the warranty.

## 11 Important notes

The following conditions apply to all goods within the wireless connectivity and sensors product range of Würth Elektronik eiSos GmbH & Co. KG:

### General customer responsibility

Some goods within the product range of Würth Elektronik eiSos GmbH & Co. KG contain statements regarding general suitability for certain application areas. These statements about suitability are based on our knowledge and experience of typical requirements concerning the areas, serve as general guidance and cannot be estimated as binding statements about the suitability for a customer application. The responsibility for the applicability and use in a particular customer design is always solely within the authority of the customer. Due to this fact, it is up to the customer to evaluate, where appropriate to investigate and to decide whether the device with the specific product characteristics described in the product specification is valid and suitable for the respective customer application or not. Accordingly, the customer is cautioned to verify that the documentation is current before placing orders.

### Customer responsibility related to specific, in particular safety-relevant applications

It has to be clearly pointed out that the possibility of a malfunction of electronic components or failure before the end of the usual lifetime cannot be completely eliminated in the current state of the art, even if the products are operated within the range of the specifications. The same statement is valid for all software source code and firmware parts contained in or used with or for products in the wireless connectivity and sensor product range of Würth Elektronik eiSos GmbH & Co. KG. In certain customer applications requiring a high level of safety and especially in customer applications in which the malfunction or failure of an electronic component could endanger human life or health, it must be ensured by most advanced technological aid of suitable design of the customer application that no injury or damage is caused to third parties in the event of malfunction or failure of an electronic component.

### Best care and attention

Any product-specific data sheets, manuals, application notes, PCNs, warnings and cautions must be strictly observed in the most recent versions and matching to the products revisions. These documents can be downloaded from the product specific sections on the wireless connectivity and sensors homepage.

### Customer support for product specifications

Some products within the product range may contain substances, which are subject to restrictions in certain jurisdictions in order to serve specific technical requirements. Necessary information is available on request. In this case, the Business Development Engineer (BDM) or the internal sales person in charge should be contacted who will be happy to support in this matter.

### Product improvements

Due to constant product improvement, product specifications may change from time to time. As a standard reporting procedure of the Product Change Notification (PCN) according to the JEDEC-Standard, we inform about major changes. In case of further queries regarding the PCN, the Business Development Engineer (BDM), the internal sales person or the technical support team in charge should be contacted. The basic responsibility of the customer as per section 11 and 11 remains unaffected.

All software like "wireless connectivity SDK", "Sensor SDK" or other source codes as well as all PC software tools are not subject to the Product Change Notification information process.

### Product life cycle

Due to technical progress and economical evaluation, we also reserve the right to discontinue production and delivery of products. As a standard reporting procedure of the Product Termination Notification (PTN) according to the JEDEC-Standard we will inform at an early stage about inevitable product discontinuance. According to this, we cannot ensure that all products within our product range will always be available. Therefore, it needs to be verified with the Business Development Engineer (BDM) or the internal sales person in charge about the current product availability expectancy before or when the product for application design-in disposal is considered. The approach named above does not apply in the case of individual agreements deviating from the foregoing for customer-specific products.

### Property rights

All the rights for contractual products produced by Würth Elektronik eiSos GmbH & Co. KG on the basis of ideas, development contracts as well as models or templates that are subject to copyright, patent or commercial protection supplied to the customer will remain with Würth Elektronik eiSos GmbH & Co. KG. Würth Elektronik eiSos GmbH & Co. KG does not warrant or represent that any license, either expressed or implied, is granted under any patent right, copyright, mask work right, or other intellectual property right relating to any combination, application, or process in which Würth Elektronik eiSos GmbH & Co. KG components or services are used.

### General terms and conditions

Unless otherwise agreed in individual contracts, all orders are subject to the current version of the "General Terms and Conditions of Würth Elektronik eiSos Group", last version available at [www.we-online.com](http://www.we-online.com).

## 12 Legal notice

### Exclusion of liability

Würth Elektronik eiSos GmbH & Co. KG considers the information in this document to be correct at the time of publication. However, Würth Elektronik eiSos GmbH & Co. KG reserves the right to modify the information such as technical specifications or functions of its products or discontinue the production of these products or the support of one of these products without any written announcement or notification to customers. The customer must make sure that the information used corresponds to the latest published information. Würth Elektronik eiSos GmbH & Co. KG does not assume any liability for the use of its products. Würth Elektronik eiSos GmbH & Co. KG does not grant licenses for its patent rights or for any other of its intellectual property rights or third-party rights.

Notwithstanding anything above, Würth Elektronik eiSos GmbH & Co. KG makes no representations and/or warranties of any kind for the

provided information related to their accuracy, correctness, completeness, usage of the products and/or usability for customer applications. Information published by Würth Elektronik eiSos GmbH & Co. KG regarding third-party products or services does not constitute a license to use such products or services or a warranty or endorsement thereof.

#### Suitability in customer applications

The customer bears the responsibility for compliance of systems or units, in which Würth Elektronik eiSos GmbH & Co. KG products are integrated, with applicable legal regulations. Customer acknowledges and agrees that it is solely responsible for compliance with all legal, regulatory and safety-related requirements concerning its products, and any use of Würth Elektronik eiSos GmbH & Co. KG components in its applications, notwithstanding any applications-related information or support that may be provided by Würth Elektronik eiSos GmbH & Co. KG. Customer represents and agrees that it has all the necessary expertise to create and implement safeguards which anticipate dangerous consequences of failures, monitor failures and their consequences lessen the likelihood of failures that might cause harm and take appropriate remedial actions. The customer will fully indemnify Würth Elektronik eiSos GmbH & Co. KG and its representatives against any damages arising out of the use of any Würth Elektronik eiSos GmbH & Co. KG components in safety-critical applications.

#### Trademarks

AMBER wireless is a registered trademark of Würth Elektronik eiSos GmbH & Co. KG. All other trademarks, registered trademarks, and product names are the exclusive property of the respective owners.

#### Usage restriction

Würth Elektronik eiSos GmbH & Co. KG products have been designed and developed for usage in general electronic equipment only. This product is not authorized for use in equipment where a higher safety standard and reliability standard is especially required or where a failure of the product is reasonably expected to cause severe personal injury or death, unless the parties have executed an agreement specifically governing such use. Moreover, Würth Elektronik eiSos GmbH & Co. KG products are neither designed nor intended for use in areas such as military, aerospace, aviation, nuclear control, submarine, transportation (automotive control, train control, ship control), transportation signal, disaster prevention, medical, public information network etc. Würth Elektronik eiSos GmbH & Co. KG must be informed about the intent of such usage before the design-in stage. In addition, sufficient reliability evaluation checks for safety must be performed on every electronic component, which is used in electrical circuits that require high safety and reliability function or performance. By using Würth Elektronik eiSos GmbH & Co. KG products, the customer agrees to these terms and conditions.

## 13 License terms for Würth Elektronik eiSos GmbH & Co. KG sensor product software and source code

These license terms will take effect upon the purchase and usage of the Würth Elektronik eiSos GmbH & Co. KG sensor products. You hereby agree that these license terms are applicable to the product and the incorporated software, firmware and source codes (collectively, "Software") made available by Würth Elektronik eiSos in any form, including but not limited to binary, executable or source code form. The software included in any Würth Elektronik eiSos sensor product is purchased to you on the condition that you accept the terms and conditions of these license terms. You agree to comply with all provisions under these license terms.

#### Limited license

Würth Elektronik eiSos hereby grants you a limited, non-exclusive, non-transferable and royalty-free license to use the software and under the conditions that will be set forth in these license terms. You are free to use the provided software only in connection with one of the products from Würth Elektronik eiSos to the extent described in these license terms.

You are entitled to change or alter the source code for the sole purpose of creating an application embedding the Würth Elektronik eiSos sensor product. The transfer of the source code to third parties is allowed to the sole extent that the source code is used by such third parties in connection with our product or another hardware provided by Würth Elektronik eiSos under strict adherence of these license terms. Würth Elektronik eiSos will not assume any liability for the usage of the incorporated software and the source code.

You are not entitled to transfer the source code in any form to third parties without prior written consent of Würth Elektronik eiSos.

You are not allowed to reproduce, translate, reverse engineer, decompile, disassemble or create derivative works of the incorporated software and the source code in whole or in part.

No more extensive rights to use and exploit the products are granted to you.

#### Usage and obligations

The responsibility for the applicability and use of the Würth Elektronik eiSos sensor product with the incorporated software in a particular customer design is always solely within the authority of the customer. Due to this fact, it is up to you to evaluate and investigate, where appropriate, and to decide whether the device with the specific product characteristics described in the product specification is valid and suitable for your respective application or not.

You are responsible for using the Würth Elektronik eiSos sensor product with the incorporated software in compliance with all applicable product liability and product safety laws. You acknowledge to minimize the risk of loss and harm to individuals and bear the risk for failure leading to personal injury or death due to your usage of the product.

Würth Elektronik eiSos' products are not authorized for use in safety-critical applications, or where a failure of the product is reasonably expected to cause severe personal injury or death. Moreover, Würth Elektronik eiSos' products are neither designed nor intended for use in areas such as military, aerospace, aviation, nuclear control, submarine, transportation (automotive control, train control, ship control), transportation signal, disaster prevention, medical, public information network etc. You shall inform Würth Elektronik eiSos about the intent of such usage before design-in stage. In certain customer applications requiring a very high level of safety and in which the malfunction or failure of an electronic component could endanger human life or health, you must ensure to have all necessary expertise in the safety and regulatory ramifications of your applications. You acknowledge and agree that you are solely responsible for all legal, regulatory and safety-related requirements concerning your products and any use of Würth Elektronik eiSos' products in such safety-critical applications, notwithstanding any applications-related

information or support that may be provided by Würth Elektronik eiSos. YOU SHALL INDEMNIFY WÜRTH ELEKTRONIK EISOS AGAINST ANY DAMAGES ARISING OUT OF THE USE OF WÜRTH ELEKTRONIK EISOS' PRODUCTS IN SUCH SAFETY-CRITICAL APPLICATIONS.

### Ownership

The incorporated software created by Würth Elektronik eiSos is and will remain the exclusive property of Würth Elektronik eiSos.

### Disclaimer of warranty

THE SOFTWARE AND IT'S SOURCE CODE IS PROVIDED "AS IS". YOU ACKNOWLEDGE THAT WÜRTH ELEKTRONIK EISOS MAKES NO REPRESENTATIONS AND WARRANTIES OF ANY KIND RELATED TO, BUT NOT LIMITED TO THE NON-INFRINGEMENT OF THIRD PARTIES' INTELLECTUAL PROPERTY RIGHTS OR THE MERCHANTABILITY OR FITNESS FOR YOUR INTENDED PURPOSE OR USAGE. WÜRTH ELEKTRONIK EISOS DOES NOT WARRANT OR REPRESENT THAT ANY LICENSE, EITHER EXPRESS OR IMPLIED, IS GRANTED UNDER ANY PATENT RIGHT, COPYRIGHT, MASK WORK RIGHT, OR OTHER INTELLECTUAL PROPERTY RIGHT RELATING TO ANY COMBINATION, MACHINE, OR PROCESS IN WHICH THE WÜRTH ELEKTRONIK EISOS' PRODUCT WITH THE INCORPORATED SOFTWARE IS USED. INFORMATION PUBLISHED BY WÜRTH ELEKTRONIK EISOS REGARDING THIRD-PARTY PRODUCTS OR SERVICES DOES NOT CONSTITUTE A LICENSE FROM WÜRTH ELEKTRONIK EISOS TO USE SUCH PRODUCTS OR SERVICES OR A WARRANTY OR ENDORSEMENT THEREOF.

### Limitation of liability

Any liability not expressly provided by Würth Elektronik eiSos shall be disclaimed.

You agree to hold us harmless from any third-party claims related to your usage of the Würth Elektronik eiSos' products with the incorporated software and source code. Würth Elektronik eiSos disclaims any liability for any alteration, development created by you or your customers as well as for any combination with other products.

### Applicable law and jurisdiction

Applicable law to these license terms shall be the laws of the Federal Republic of Germany. Any dispute, claim or controversy arising out of or relating to these license terms shall be resolved and finally settled by the court competent for the location of Würth Elektronik eiSos registered office.

### Severability clause

If a provision of these license terms is or becomes invalid, unenforceable or null and void, this shall not affect the remaining provisions of the terms. The parties shall replace any such provisions with new valid provisions that most closely approximate the purpose of the terms.

### Miscellaneous

Würth Elektronik eiSos reserves the right at any time to change this terms at its own discretion. It is your responsibility to check at Würth Elektronik eiSos homepage for any updates. Your continued usage of the products will be deemed as the acceptance of the change.

We recommend you to be updated about the status of new software, which is available on our website or in our data sheet, and to implement new software in your device where appropriate.

By ordering a product, you accept these license terms in all terms.

## List of Figures

1	Block diagram . . . . .	8
2	Pin specifications - vertical nozzles (top view) . . . . .	17
3	Pin specifications- horizontal nozzles (top view) . . . . .	17
4	Master-slave concept . . . . .	19
5	<i>SDA</i> and <i>SCL</i> logic levels . . . . .	20
6	Data validity, START and STOP condition . . . . .	21
7	Slave address format . . . . .	22
8	Complete data transfer . . . . .	23
9	Application circuit with I <sup>2</sup> C interface (top view) . . . . .	25
10	Reading output data with I <sup>2</sup> C interface . . . . .	26
11	Sensor dimensions: Vertical nozzles [mm] . . . . .	34
12	Sensor dimensions: Horizontal-barbed nozzles [mm] . . . . .	35
13	Recommended land pattern [mm] (top view) . . . . .	36
14	Marking information . . . . .	37
15	Reflow soldering profile . . . . .	39

## List of Tables

1	Ordering information . . . . .	7
2	General information . . . . .	9
3	Media compatibility . . . . .	9
4	Absolute maximum ratings . . . . .	10
5	Pressure sensor specifications (part nr.: 25131308xxx01) . . . . .	11
6	Pressure sensor specifications (part nr.: 2513130810001) . . . . .	12
7	Pressure sensor specifications (part nr.: 2513130810101) . . . . .	12
8	Pressure sensor specifications (part nr.: 2513130810201) . . . . .	13
9	Pressure sensor specifications (part nr.: 2513130810301) . . . . .	13
10	Pressure sensor specifications (Part nr.: 2513130810401) . . . . .	14
11	Pressure sensor specifications (Part nr.: 2513130815401) . . . . .	14
12	Pressure sensor specifications (part nr.: 2513130810102) . . . . .	15
13	Pressure sensor specifications (Part nr.: 2513130810402) . . . . .	15
14	Temperature sensor specifications . . . . .	16
15	Electrical specifications . . . . .	16
16	Pin description . . . . .	18
17	I <sup>2</sup> C timing parameters . . . . .	24
18	Digital pressure output: bidirectional . . . . .	27
19	Digital pressure output: unidirectional . . . . .	27
20	Digital pressure output . . . . .	27
21	Digital temperature output: all devices . . . . .	28
22	Analog pressure output . . . . .	31
23	Analog pressure output . . . . .	31
24	Analog pressure output . . . . .	32
25	Analog pressure output . . . . .	32
26	Analog pressure output . . . . .	32
27	look up table: Digital output . . . . .	33

---

28	look up table: Analog output . . . . .	33
29	Classification reflow soldering profile, Note: refer to IPC/JEDEC J-STD-020E . . .	38
30	Package classification reflow temperature, PB-free assembly, Note: refer to IPC/- JEDEC J-STD-020E . . . . .	38



**Contact**

Würth Elektronik eiSos GmbH & Co. KG  
Division Wireless Connectivity & Sensors

Max-Eyth-Straße 1  
74638 Waldenburg  
Germany

Tel.: +49 651 99355-0  
Fax.: +49 651 99355-69  
[www.we-online.com/wireless-connectivity](http://www.we-online.com/wireless-connectivity)

**WÜRTH ELEKTRONIK** MORE THAN YOU EXPECT