

USER MANUAL

EVALUATION BOARD/KIT FOR
RADIO MODULES
STEPHANO-I AND ORTHOSIE-I

2617011025000, 2617011022000

VERSION 1.1

OCTOBER 10, 2024

WÜRTH ELEKTRONIK MORE THAN YOU EXPECT

MUST READ

Check for firmware updates

Before using the product, make sure you use the most recent firmware version, data sheet, and user manual. This is especially important for Wireless Connectivity products that were not purchased directly from Würth Elektronik eiSos. A firmware update on these respective products may be required.

We strongly recommend including the possibility of a firmware update in the customer system design.

Revision history

Manual version	HW version	Notes	Date
1.0	1.0	<ul style="list-style-type: none">• Initial version	May 2024
1.1	1.0	<ul style="list-style-type: none">• Added chapter Marking• Added description of available baud rates supported by the FTDI chipset	October 2024

Abbreviations

Abbreviation	Name	Description
BDM	Business Development Manager	Support and sales contact person responsible for limited sales area.
BYOF	Build Your Own Firmware	Radio module without firmware to develop custom firmware
EV (board/kit)	Evaluation (board/kit)	
HIGH	High signal level	Signal level of the VDD.
LED	Light Emitting Diode	
LOW	Low signal level	Signal level of the ground.
MCU	MicroController Unit	
RF	Radio Frequency	Describes everything relating to the wireless transmission.
UART	Universal Asynchronous Receiver Transmitter	Protocol for the exchange of data in series between two devices.
VDD	Supply voltage	

Contents

1	Supported radio modules	4
2	Functional description	6
2.1	Taking into operation	6
3	Development board	7
3.1	Block diagram	7
3.2	Jumpers, connectors and pin headers	7
3.3	Connectors and pin headers	11
3.4	Buttons	13
3.4.1	Reset button	13
3.5	Function blocks	13
3.5.1	Power supply	13
3.5.1.1	External power supply	13
3.5.1.2	Bus powered, power supply through USB1	13
3.5.2	Current measurement	13
3.5.3	UART1 / USB1	14
3.5.4	UART0 / USB0	15
3.5.5	UART direct	15
3.5.6	Programming interface	15
3.6	Schematic	16
3.7	Full layout	18
3.8	Bill of materials	21
4	Marking	22
4.1	Lot number	22
5	Regulatory compliance information	23
5.1	European Conformity	23
5.2	FCC	23
5.3	Exemption clause	23
6	References	24
7	Important notes	25
8	Legal notice	25
9	License terms	26

1 Supported radio modules

The EV-Board described in this manual can be used to evaluate the following products:

WE order code	Description
2617011022000	BYOF radio module Orthosie-I [1]
2617011025000	WiFi and Bluetooth® LE combo module Stephano-I [2]

Table 1: Compatibility

The EV-Kits can be ordered using the following order codes:

WE order code	Description
2617029022001	EV-Kit Orthosie-I
2617029025001	EV-Kit Stephano-I

Table 2: Order codes

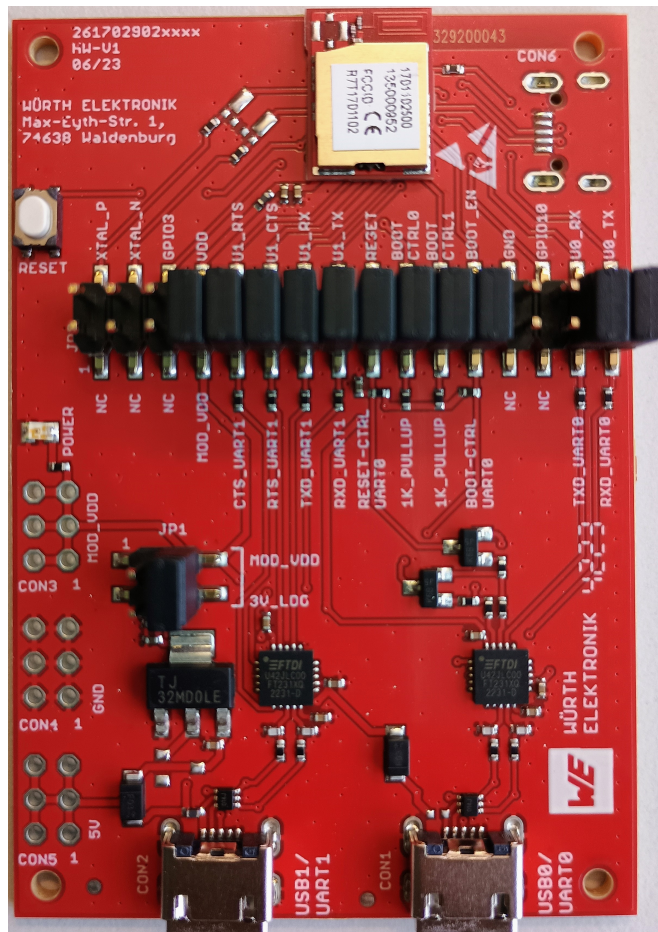

Figure 1: Stephano-I EV-Board

Kit content 2617029022001	Quantity
EV-Board with Orthosie-I	1
USB2 A to microUSB cable	2

Table 3: Content Orthosie-I EV-Kit

The Orthosie-I EV-Kit needs two cables as opposed to the Stephano-I EV-Kit: one cable is used for power supply and the second cable for flashing of the module. The Stephano-I EV-Kit only needs one cable for power supply.

Kit content 2617029025001	Quantity
EV-Board with Stephano-I	1
USB2 A to microUSB cable	1

Table 4: Content Stephano-I EV-Kit

2 Functional description

The EV-Board offers the user the possibility to develop hard- and software for the compatible radio module. It can be connected to a USB port of a PC.

For the connection to an MCU system, the development board is equipped with a multi-pin connector, which is connected to all pins of the radio module. Jumpers allow the module to be disconnected from components, such as the USB interface, which are not required.

Refer to our YouTube channel:

www.youtube.com/user/WuerthElektronik/videos for video tutorials, hands-ons and webinars relating to our products. Our channel will be updated regularly with new content.

2.1 Taking into operation

To run the EV-Board, the jumpers need to be placed on the default location. The default location of jumpers can be found in 3.2. Before using the EV-Kit it must be assured that the jumpers are placed in the correct position.

The corresponding FTDI driver package (www.ftdichip.com/Drivers/VCP.htm) has to be installed on your PC.

The USB1 connector can be used to power up the radio module and to communicate with the Stephano-I's AT command based firmware. Refer to the module user manual [2] for detailed module specific quick-start instructions. For Orthosie-I, USB1 is only used to supply the device with power.

The USB0 connector with the flash circuit behind allows to re-program the Espressif chipset with PC tools, like "Espressif flash download tool", or to control special test firmware provided by Espressif.

Refer to the Espressif documentation for further information: AT command documentation for Stephano-I [3], examples for Stephano-I [4] and Espressif tools download page [5].

3 Development board

3.1 Block diagram

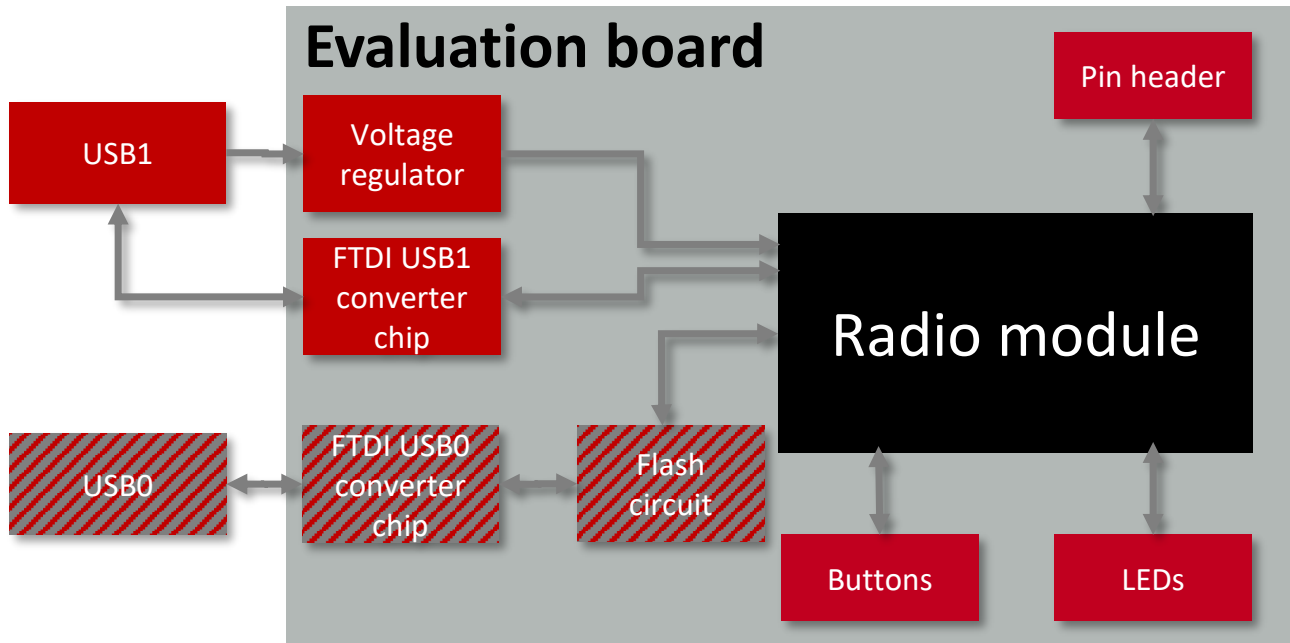

Figure 2: Block diagram



The flash circuit between the FTDI USB0 converter chip and the radio module is a circuit with transistors and resistors needed for flashing and/or erasing the chipset.

3.2 Jumpers, connectors and pin headers

The following figure shows the default positioning (marked in red) of all jumpers on the EV-Board. This section also contains the details to any jumper connection that is supported by the EV-Board. Before using the board, make sure that the jumper setting is correct.

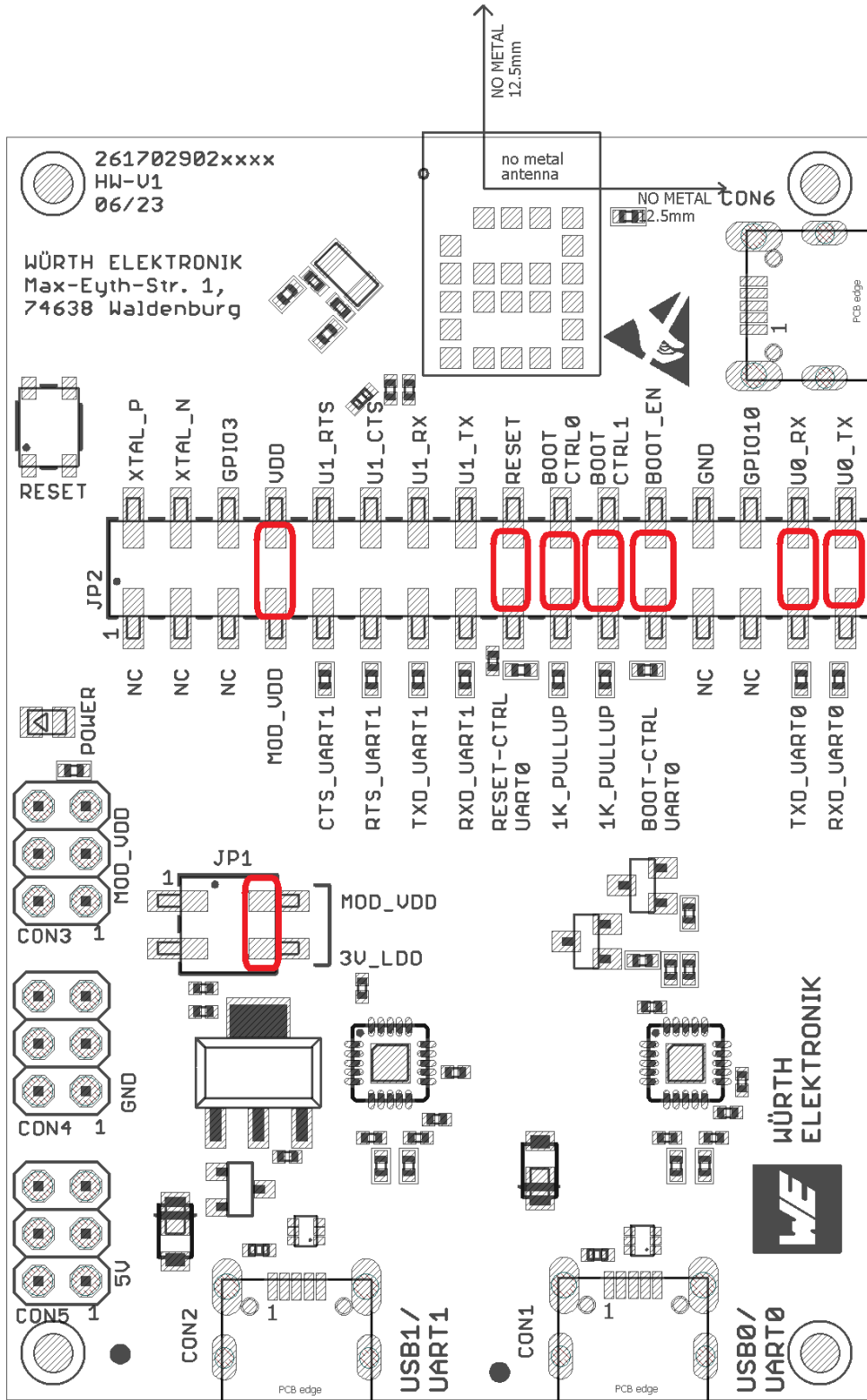

Figure 3: Orthosie-I: Default configuration of jumpers

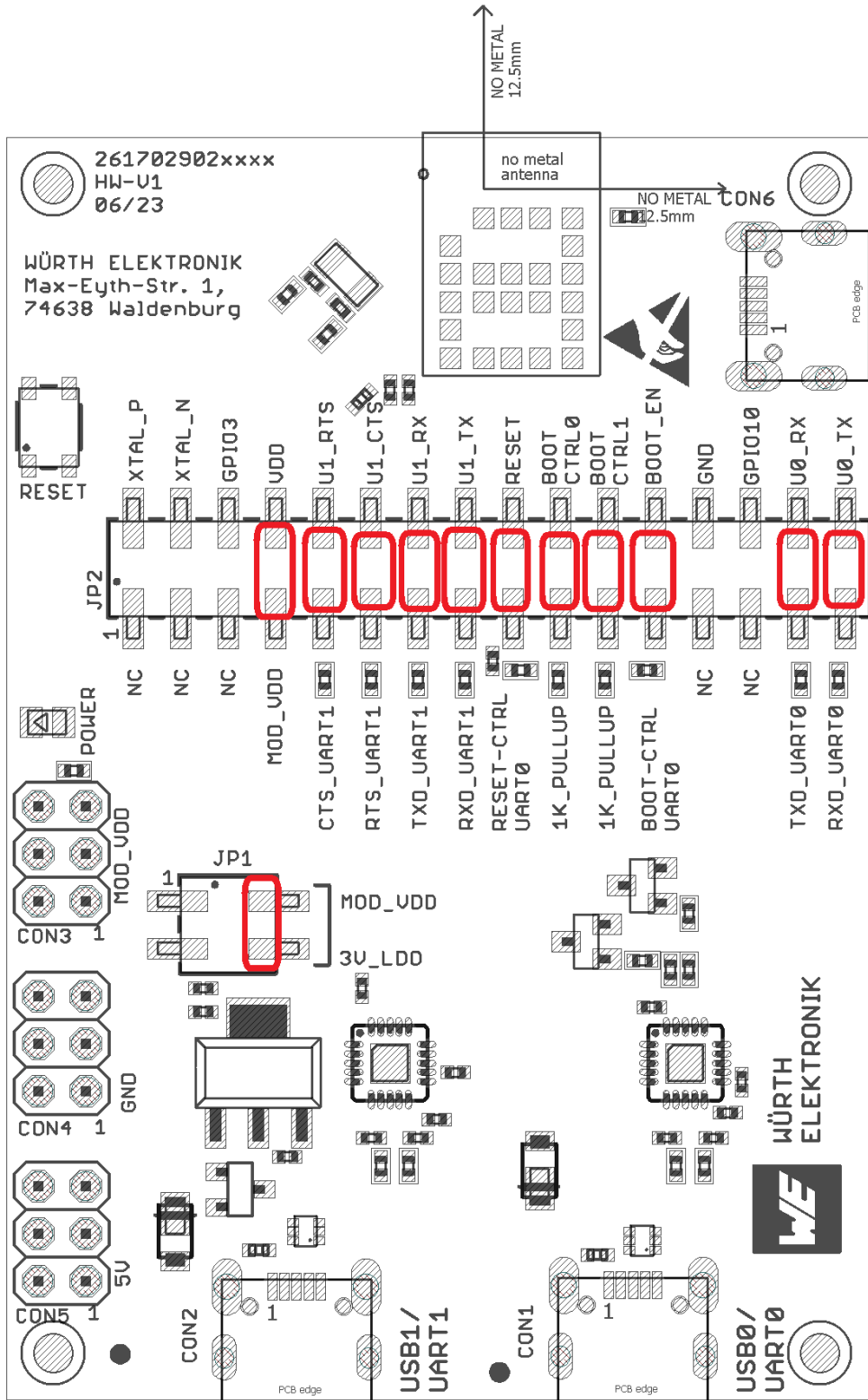

Figure 4: Stephano-I: Default configuration of jumpers

JP1	Function	Jumper set (default)
2,4	LDO power supply	Yes
2,4	External power supply	No
1	Not connected	
3	Not connected	

Table 5: Jumper JP1

JP2	Pin (Module Function)	Jumper set (default) Stephano-I	Jumper set (default) Orthosie-I
1,2	NC to XTAL_P	No	No
3,4	NC to XTAL_N	No	No
5,6	NC to GPIO3	No	No
7,8	Current measurement bridge	Yes	Yes
9,10	GPIO4 (/U1_RTS) to /CTS-FTDI0	Yes	No
11,12	GPIO5 (/U1_CTS) to /RTS-FTDI0	Yes	No
13,14	GPIO6 (/U1_RX) to /TX-FTDI0	Yes	No
15,16	GPIO7 (/U1_TX) to /RX-FTDI0	Yes	No
17,18	CHIP_EN (/RESET) to /Reset-FTDI	Yes	Yes
19,20	GPIO2 (BOOT_CTRL0) to 1k Ω pull-up	Yes	Yes
21,22	GPIO8 (BOOT_CTRL1) to 1k Ω pull-up	Yes	Yes
23,24	GPIO9 (BOOT_EN) to BOOT_CTRL	Yes	Yes
25,26	NC to GND	No	No
27,28	NC to GPIO10	No	No
29,30	GPIO20 (/U0_RX) to /TX-FTDI0	Yes	Yes
31,32	GPIO21 (/U0_TX) to /RX-FTDI0	Yes	Yes

Table 6: Jumper JP2

3.3 Connectors and pin headers

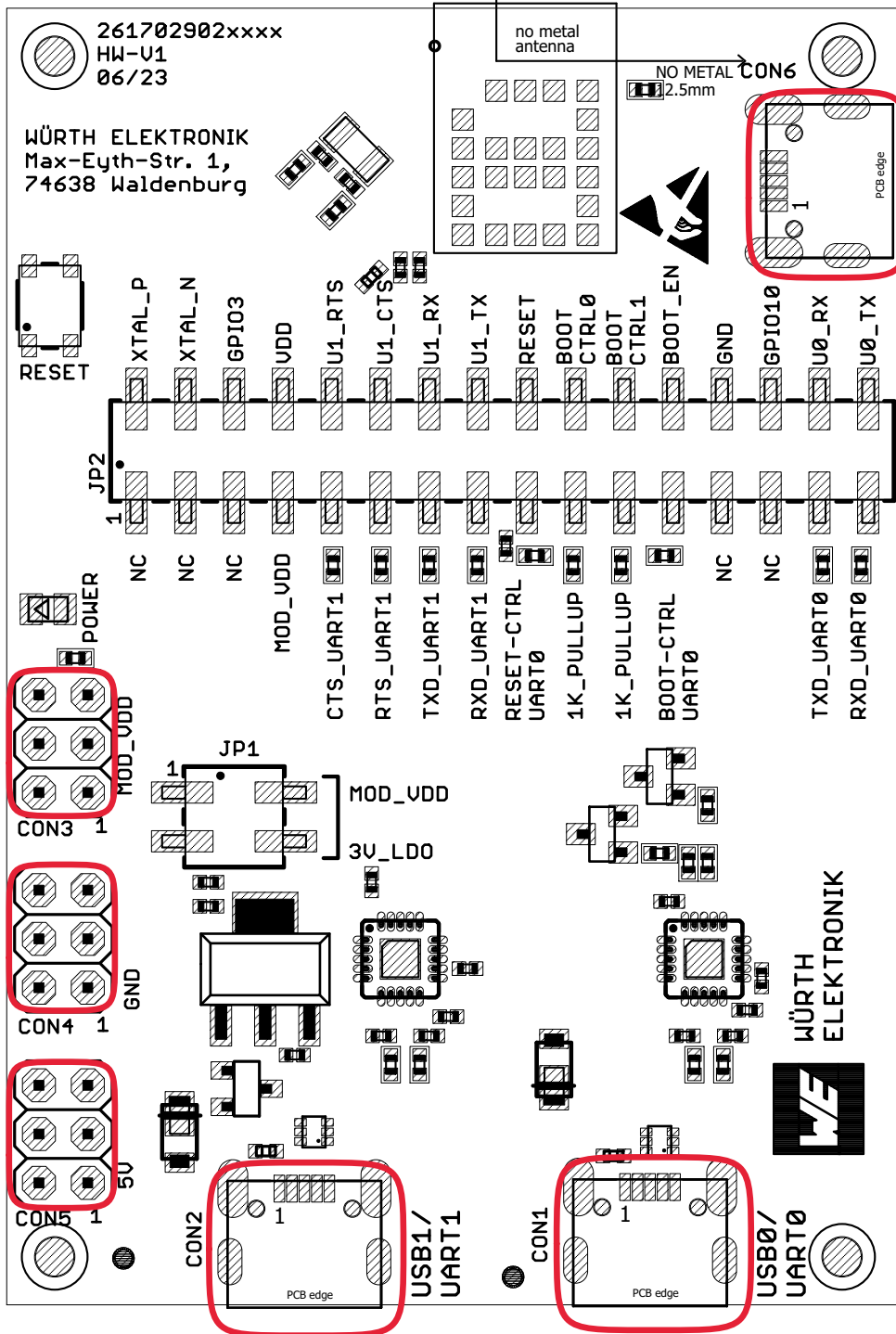

Figure 5: Connectors

Connector	Function
CON1	Debug USB0 for flashing
CON2	Application USB1 for communication and power supply
CON3	External power supply VDD (not mounted)
CON4	External power supply GND (not mounted)
CON5	External power supply 5 V (not mounted)

Table 7: Connector overview

3.4 Buttons

3.4.1 Reset button

The reset button is connected to the active low */RESET* pin of the MCU. It can be used to set the module to sleep or to reset it. For more details, refer to the radio module's user manual [2].



In case the */RESET* pin is used to set the radio module to sleep mode, remove the jumper on JP2 pin 17,18 to disconnect the pull-up resistor.

3.5 Function blocks

3.5.1 Power supply

The development board can be operated via USB1. The integrated voltage regulator regulates the connected 5 V down to 3.3 V, with which the remaining parts of the circuit are supplied. When the power is connected, the power LED will be on.

3.5.1.1 External power supply

If no jumper is set on JP1, an external 3.3 V power supply can be connected to CON3 (MOD_VDD).

3.5.1.2 Bus powered, power supply through USB1

If the jumper is set on JP1, the radio module is powered via USB1 connector.

3.5.2 Current measurement

By default, the jumper 7-8 on connector JP2 is set to supply the radio module with power. If a current meter is connected in place of the jumper, the power consumption of the radio module can be measured.

If the meter is not attached and the bridge is not set, the module will not receive a supply voltage. However, the power LED may be active, as it is connected prior to the current measurement bridge, in order not to distort the module's power consumption.



To achieve the stated low power current, the module pins must be terminated as stated in the module specific manual [2].

3.5.3 UART1 / USB1

The UART1 of the module is used for communicating with the module per AT commands. It can be connected to the USB1 converter by setting the bridge to JP2 and is available on the USB1 jack, so that the module can be connected directly to a PC. Using the FTDI-driver, the PC will show a virtual COM-Port, which can be used to communicate with the module.

In order to establish a stable UART communication between the FTDI USB to UART converter chipset and the radio module’s chipset, the difference between the baud rates of each entity must not exceed the respective immunity level. Both devices use an internal clock to generate the configured UART baud rate. Due to the fixed clock frequency, only specific baud rates can be run without frequency error.

To figure out which baud rates of the radio module can be evaluated using the mounted FTDI chipset (FT232R or FT231X), it is important to know the real baud rate B with its introduced error. To get them, the FTDI’s clock of 3000 kHz must be divided by the respective prescaler P :

$$B = \frac{3000}{P} \text{ [kBaud]}$$

The supported prescalers P can be chosen as:

$$P \in \{1, 1.5\} \text{ or } P = 2 + (N \cdot 0.125) \text{ with } N \in \{0, 1, 2, 3, 4, \dots\}$$

When a baud rate is configured in the FTDI chip, the prescaler is chosen that meets the closest baud rate. In that case, the real baud rate differs from the configured one, introducing a UART clock error, which may lead to UART communication issues.

Example: In case the desired baud rate $B_{desired} = 1250$ kBaud, the desired prescaler is $P_{desired} = \frac{3000}{1250} = 2.4$. The closest prescaler P is determined by $P = 2 + (N \cdot 0.125) = 2.375$ with $N = 3$. This results in a real baud rate $B = \frac{3000}{2.375} = 1263$ kBaud, which introduces an error of $\frac{B - B_{desired}}{B_{desired}} = 1.04\%$ with respect to the desired baud rate.

Desired baud rate [kBaud]	Closest prescaler P	Real baud rate B [kBaud]	Error [%]
3000	1	3000	0
2500	1.5	2000	-20
2000	1.5	2000	0
1500	2	1500	0
1250	2.375	1263	1.04
1411.764706	2.125	1411.764706	0
⋮	⋮	⋮	⋮
1000	3	1000	0
921.6	3.25	923.0769231	0.16
⋮	⋮	⋮	⋮
230.4	13	230.7692308	0.16
⋮	⋮	⋮	⋮
115.2	26	115.3846154	0.15

⋮	⋮	⋮	⋮
38.4	78.125	38.4	0
⋮	⋮	⋮	⋮
19.2	156.25	19.2	0
⋮	⋮	⋮	⋮
9.6	312.5	9.6	0
⋮	⋮	⋮	⋮

Table 8: Example baud rates

3.5.4 UART0 / USB0

The UART0 of the module is used for flashing and debugging purposes. It can be connected to the USB0 converter by setting the bridge to JP2 and is available on the USB0 jack, so that the module can be connected directly to a PC. Using the FTDI-driver, the PC will show a virtual COM-Port, which can be used to communicate with the module.

3.5.5 UART direct

If an MCU is to be connected to the module, remove the bridges on JP2. The UART can be connected directly on the pin strip JP2 (all even numbered pins). The module RXD line must be handled accordingly by your host (i.e. pulled up while inactive and during module boot-up). Check that the /RESET pin and boot pins are on the correct level to start-up the application. Beware of IO level incompatibility. The host must obey the values stated in the module’s manual [2]. Especially the IO level restrictions must be implemented by a host system (i.e. using a level shifter to use the allowed IO levels).

3.5.6 Programming interface

The radio module can be programmed by the integrated serial bootloader. To use that, the UART0 as well as the /RESET and /BOOT_EN must be driven accordingly. The EV-Board implements the needed hardware layout of these pins, such that the USB0 interface can be used with the corresponding flash software tools.

3.6 Schematic

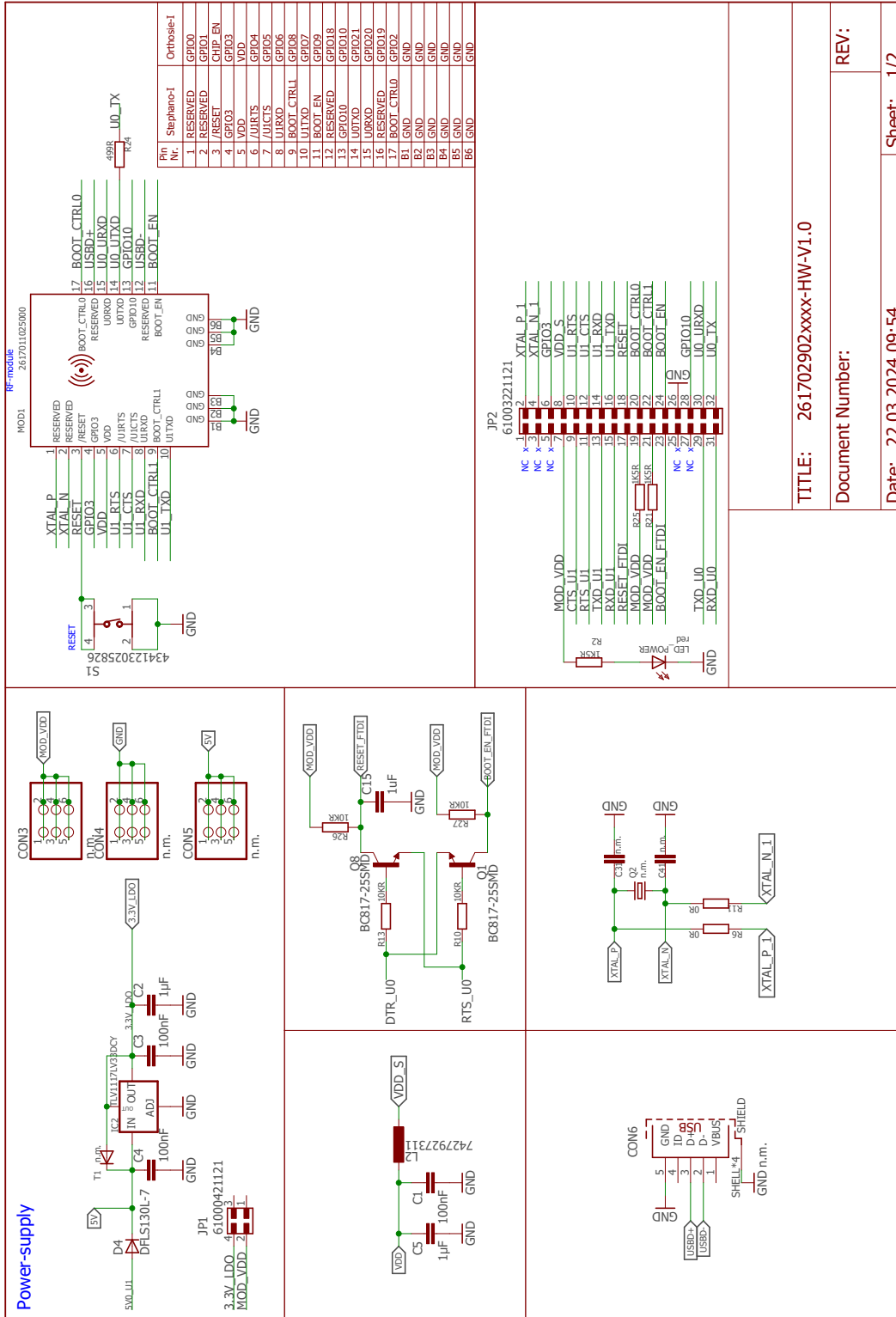

Figure 6: Circuit diagram (part 1)

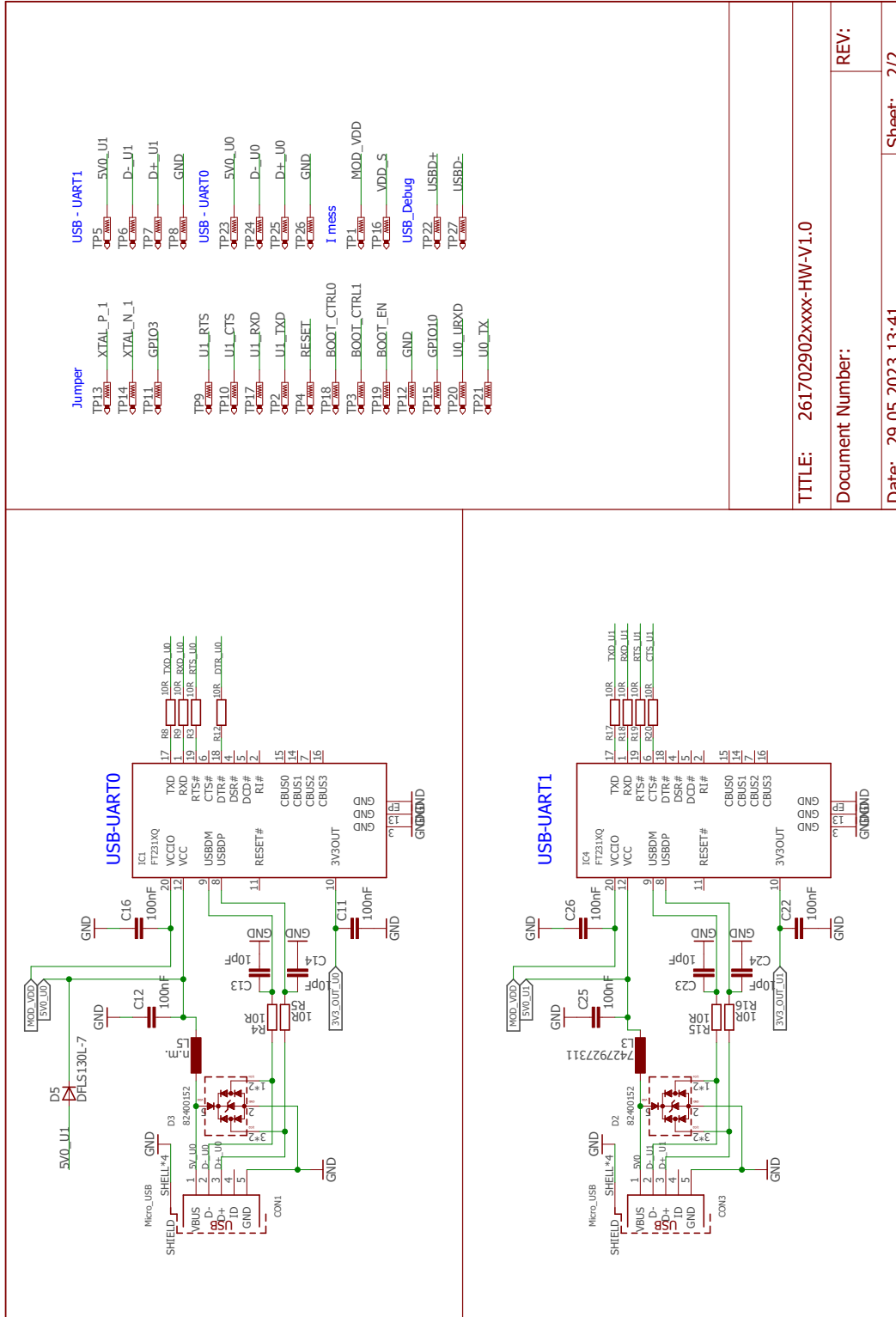

Figure 7: Circuit diagram (part 2)

3.7 Full layout

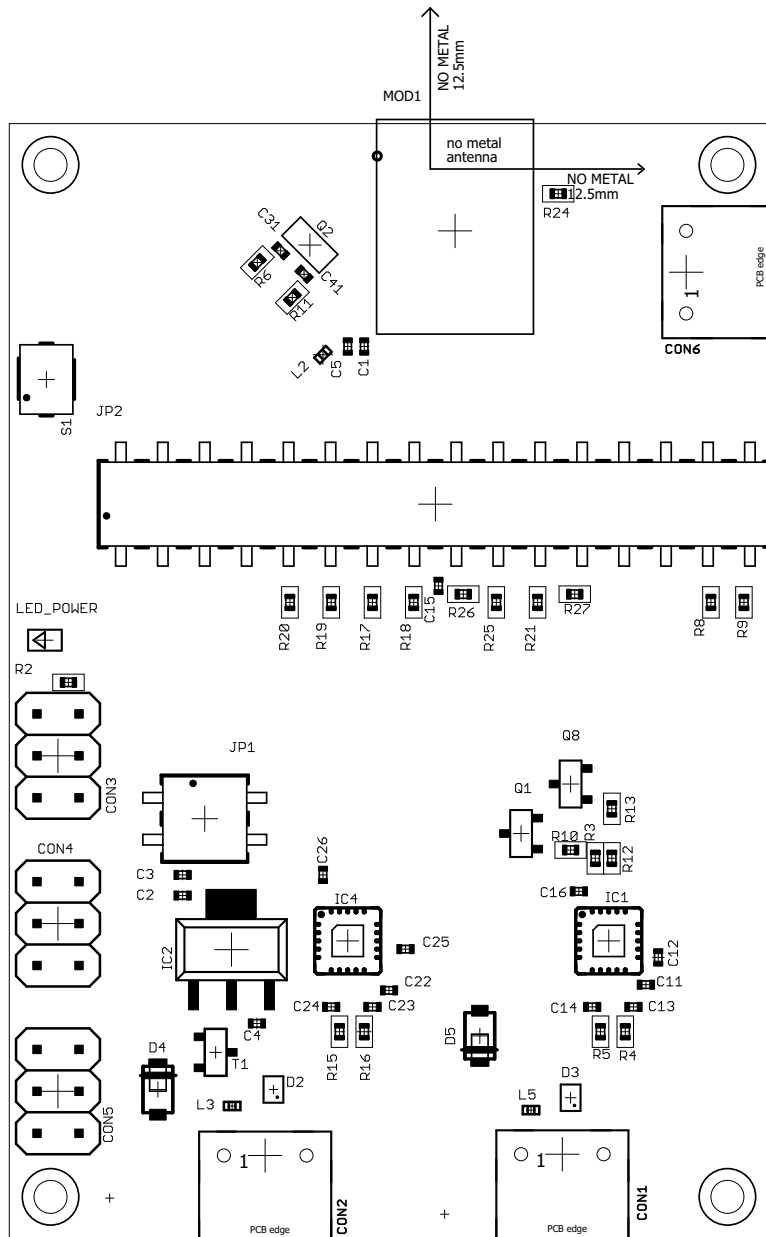

Figure 8: Assembly diagram

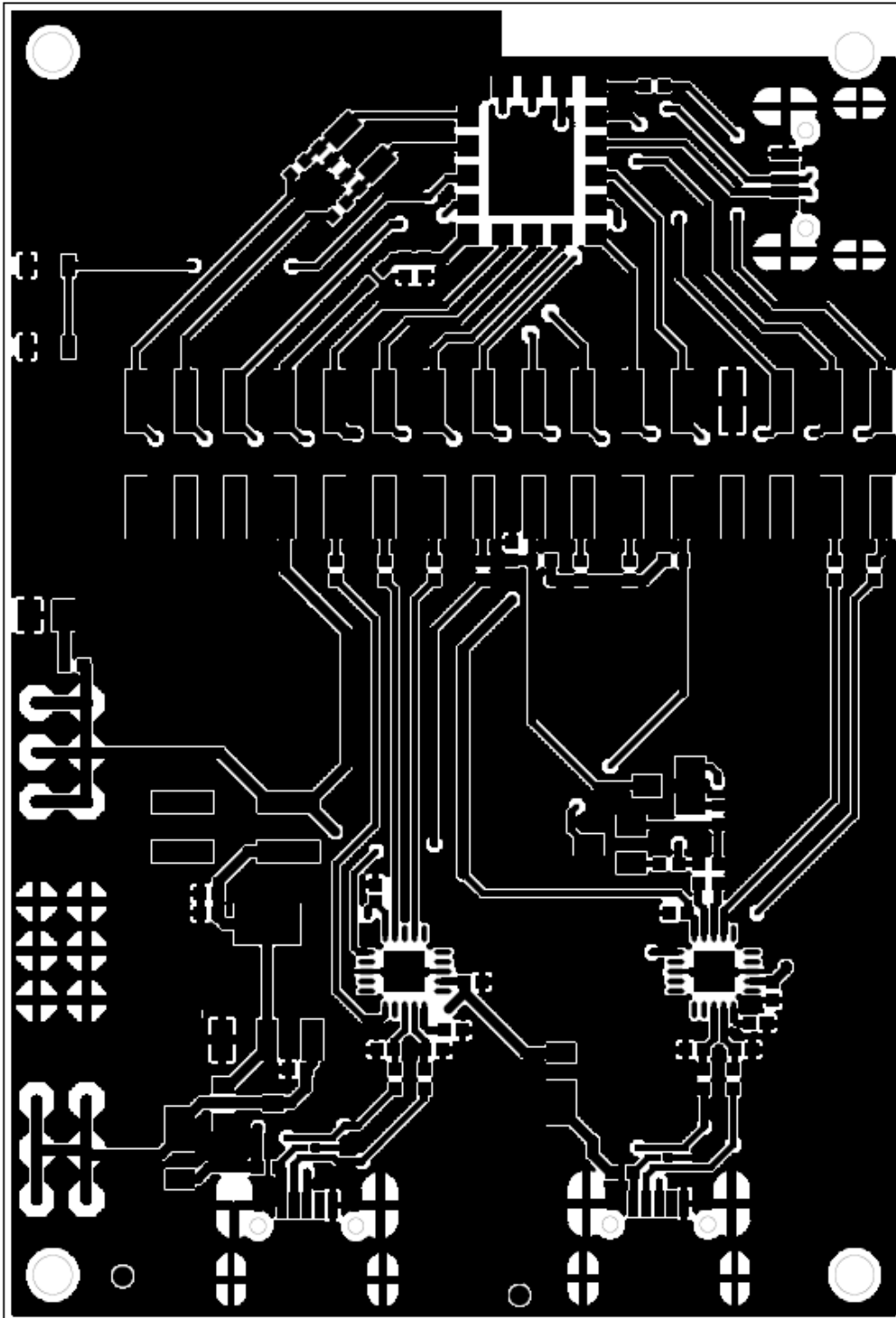

Figure 9: Top layer

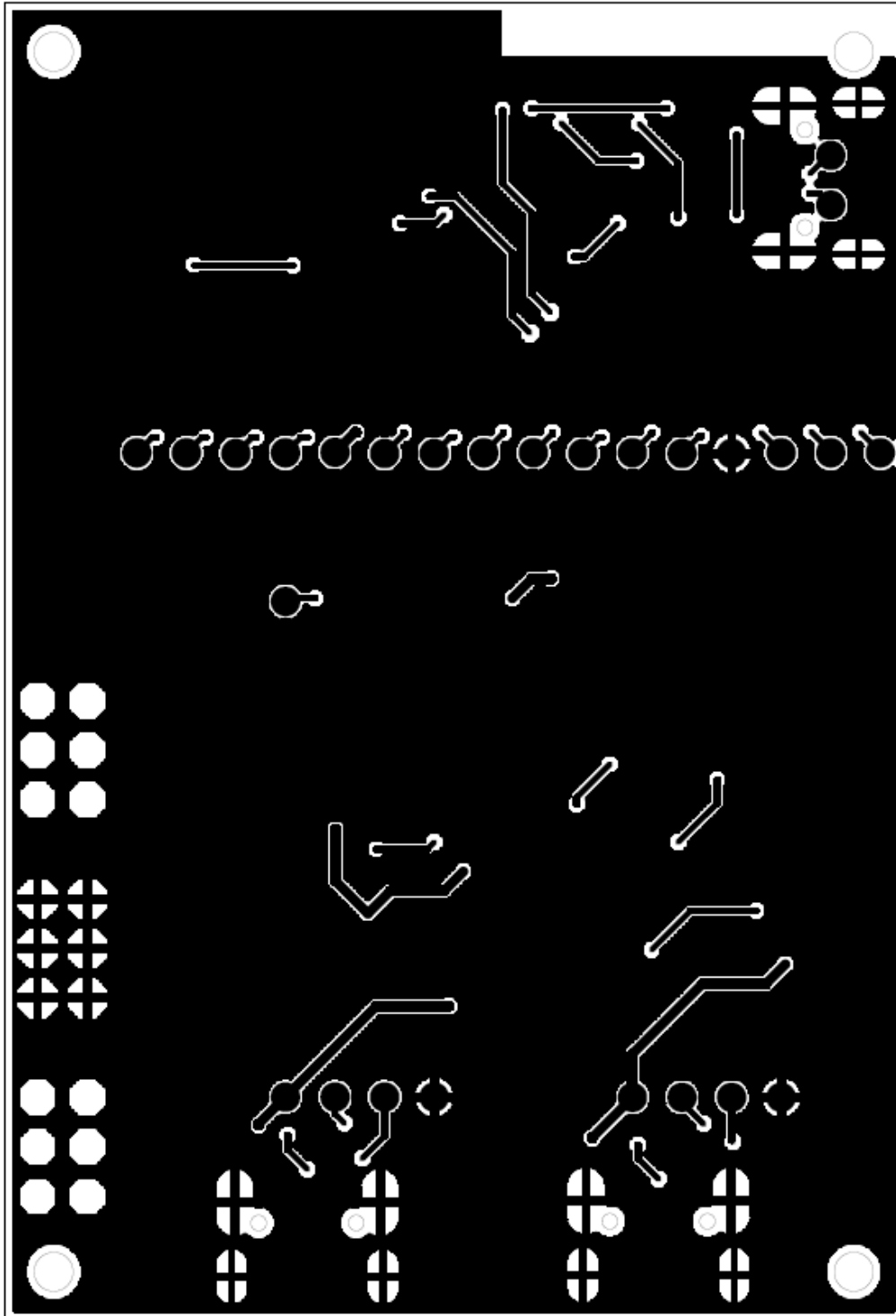

Figure 10: Bottom layer

3.8 Bill of materials

Part	Value	Package	MANUFACTURER	NR
MOD1	Stephano-I / Orthosie-I	WE-FP-7	Würth Elektronik	2617011025000 / 2617011025000
C1	100nF	C0402_IPC	Würth Elektronik	885012205037
C2	1µF	C0402_IPC	Würth Elektronik	885012105012
C3	100nF	C0402_IPC	Würth Elektronik	885012205037
C4	100nF	C0402_IPC	Würth Elektronik	885012205037
C5	1µF	C0402_IPC	Würth Elektronik	885012105012
C6	n.m.	C0402_IPC		
C7	n.m.	C0402_IPC		
C8	n.m.	C0402_IPC		
C9	22pF	C0402_IPC	Würth Elektronik	885012005057
C10	n.m.	C0402_IPC		
C11	100nF	C0402_IPC	Würth Elektronik	885012205037
C12	100nF	C0402_IPC	Würth Elektronik	885012205037
C13	10pF	C0402_IPC	Würth Elektronik	885012005055
C14	10pF	C0402_IPC	Würth Elektronik	885012005055
C15	1uF	C0402_IPC	Würth Elektronik	885012105012
C16	100nF	C0402_IPC	Würth Elektronik	885012205037
C22	100nF	C0402_IPC	Würth Elektronik	885012205037
C23	10pF	C0402_IPC	Würth Elektronik	885012005055
C24	10pF	C0402_IPC	Würth Elektronik	885012005055
C25	100nF	C0402_IPC	Würth Elektronik	885012205037
C26	100nF	C0402_IPC	Würth Elektronik	885012205037
C31	n.m.	C0402_IPC		
C41	n.m.	C0402_IPC		
CON1	Micro_USB	629105150521	Würth Elektronik	629105150521
CON2	Micro_USB	629105150521	Würth Elektronik	629105150521
CON6	n.m.	629105150521		
CON3	n.m.	2X03		
CON4	n.m.	2X03		
CON5	n.m.	2X03		
D2	82400152	WE-TVS_SOT563	Würth Elektronik	82400152
D3	82400152	WE-TVS_SOT563	Würth Elektronik	82400152
D4	DFLS130L-7	SOD123_POWERDI	Diodes incorporated	DFLS130L-7
D5	DFLS130L-7	SOD123_POWERDI	Diodes incorporated	DFLS130L-7
IC1	FT231XQ	QLP20	FTDI	FT231XQ-R
IC2	TLV1117LV33DCY	SOT223-4	TI	TLV1117LV33DCY
IC4	FT231XQ	QLP20	FTDI	FT231XQ-R
JP1	61000421121	61000421121	Würth Elektronik	61000421121
JP2	61003221121	61003221121	Würth Elektronik	61003221121

4 Marking

4.1 Lot number

The 15 digit lot number is printed in numerical digits as well as in form of a machine readable bar code. It is divided into 5 blocks as shown in the following picture and can be translated according to the following table.

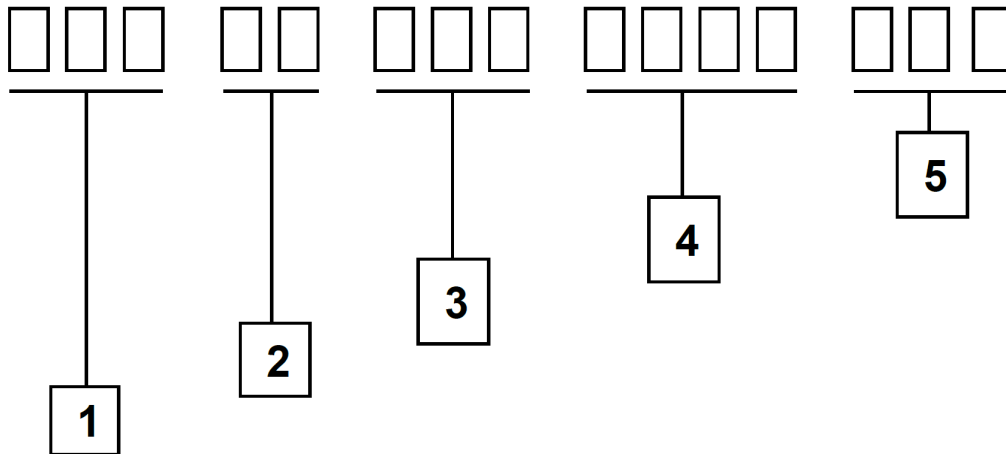

Figure 11: Lot number structure

Block	Information	Example(s)
1	eiSos internal, 3 digits	438
2	eiSos internal, 2 digits	01
3	Radio module hardware version, 3 digits	V2.4 = 024, V12.2 = 122
4	Date code, 4 digits	1703 = week 03 in year 2017, 1816 = week 16 in year 2018
5	Radio module firmware version, 3 digits	V3.2 = 302, V5.13 = 513

Table 9: Lot number details

As the user can perform a firmware update the printed lot number only shows the factory delivery state. The currently installed firmware can be requested from the module using the corresponding product specific command. The firmware version as well as the hardware version are restricted to show only major and minor version not the patch identifier.

5 Regulatory compliance information

5.1 European Conformity

Pursuant to Article 1 (2.) of the EU directive 2014/53/EU, Article 1 (2.) the directive does not apply to equipment listed in Annex I (4.): custom-built EV-Kits designed for professionals to be used solely at research and development facilities for such purposes.

5.2 FCC

Pursuant to §2.803 (c) of Title 47 Chapter I Subchapter A Part 2 Subpart I, the EV-Kit falls under the FCC exception. Therefore it is marked as "For evaluation only; not FCC approved for resale".

5.3 Exemption clause

Relevant regulation requirements are subject to change. Würth Elektronik eiSos does not guarantee the accuracy of the before mentioned information. Directives, technical standards, procedural descriptions and the like may be interpreted differently by the national authorities. Equally, the national laws and restrictions may vary with the country. In case of doubt or uncertainty, we recommend that you consult with the authorities or official certification organizations of the relevant countries. Würth Elektronik eiSos is exempt from any responsibilities or liabilities related to regulatory compliance.

Notwithstanding the above, Würth Elektronik eiSos makes no representations and warranties of any kind related to their accuracy, correctness, completeness and/or usability for customer applications. No responsibility is assumed for inaccuracies or incompleteness.

6 References

- [1] Würth Elektronik. Orthosie-I user manual. <https://www.we-online.de/katalog/de/manual/2617011022000>.
- [2] Würth Elektronik. Stephano-I user manual. <https://www.we-online.de/katalog/de/manual/2617011025000>.
- [3] Espressif. AT command documentation for Stephano-I, version 3.2.0.0. <https://docs.espressif.com/projects/esp-at/en/release-v3.2.0.0/esp32c3/index.html>.
- [4] Espressif. Examples for Stephano-I, version 3.2.0.0. https://docs.espressif.com/projects/esp-at/en/release-v3.2.0.0/esp32c3/AT_Command_Examples/index.html.
- [5] Espressif. Espressif tools download page. <https://www.espressif.com/en/support/download/other-tools>.

7 Important notes

The following conditions apply to all goods within the wireless connectivity and sensors product range of Würth Elektronik eiSos GmbH & Co. KG:

General customer responsibility

Some goods within the product range of Würth Elektronik eiSos GmbH & Co. KG contain statements regarding general suitability for certain application areas. These statements about suitability are based on our knowledge and experience of typical requirements concerning the areas, serve as general guidance and cannot be estimated as binding statements about the suitability for a customer application. The responsibility for the applicability and use in a particular customer design is always solely within the authority of the customer. Due to this fact, it is up to the customer to evaluate, where appropriate to investigate and to decide whether the device with the specific product characteristics described in the product specification is valid and suitable for the respective customer application or not. Accordingly, the customer is cautioned to verify that the documentation is current before placing orders.

Customer responsibility related to specific, in particular safety-relevant applications

It has to be clearly pointed out that the possibility of a malfunction of electronic components or failure before the end of the usual lifetime cannot be completely eliminated in the current state of the art, even if the products are operated within the range of the specifications. The same statement is valid for all software source code and firmware parts contained in or used with or for products in the wireless connectivity and sensor product range of Würth Elektronik eiSos GmbH & Co. KG. In certain customer applications requiring a high level of safety and especially in customer applications in which the malfunction or failure of an electronic component could endanger human life or health, it must be ensured by most advanced technological aid of suitable design of the customer application that no injury or damage is caused to third parties in the event of malfunction or failure of an electronic component.

Best care and attention

Any product-specific data sheets, manuals, application notes, PCNs, warnings and cautions must be strictly observed in the most recent versions and matching to the products revisions. These documents can be downloaded from the product specific sections on the wireless connectivity and sensors homepage.

Customer support for product specifications

Some products within the product range may contain substances, which are subject to restrictions in certain jurisdictions in order to serve specific technical requirements. Necessary information is available on request. In this case, the Business Development Engineer (BDM) or the internal sales person in charge should be contacted who will be happy to support in this matter.

Product improvements

Due to constant product improvement, product specifications may change from time to time. As a standard reporting procedure of the Product Change Notification (PCN) according to the JEDEC-Standard, we inform about major changes. In case of further queries regarding the PCN, the Business Development Engineer (BDM), the internal sales person or the technical support team in charge should be contacted. The basic responsibility of the customer as per section 7 and 7 remains unaffected.

All software like "wireless connectivity SDK", "Sensor SDK" or other source codes as well as all PC software tools are not subject to the Product Change Notification information process.

Product life cycle

Due to technical progress and economical evaluation, we also reserve the right to discontinue production and delivery of products. As a standard reporting procedure of the Product Termination Notification (PTN) according to the JEDEC-Standard we will inform at an early stage about inevitable product discontinuance. According to this, we cannot ensure that all products within our product range will always be available. Therefore, it needs to be verified with the Business Development Engineer (BDM) or the internal sales person in charge about the current product availability expectancy before or when the product for application design-in disposal is considered. The approach named above does not apply in the case of individual agreements deviating from the foregoing for customer-specific products.

Property rights

All the rights for contractual products produced by Würth Elektronik eiSos GmbH & Co. KG on the basis of ideas, development contracts as well as models or templates that are subject to copyright, patent or commercial protection supplied to the customer will remain with Würth Elektronik eiSos GmbH & Co. KG. Würth Elektronik eiSos GmbH & Co. KG does not warrant or represent that any license, either expressed or implied, is granted under any patent right, copyright, mask work right, or other intellectual property right relating to any combination, application, or process in which Würth Elektronik eiSos GmbH & Co. KG components or services are used.

General terms and conditions

Unless otherwise agreed in individual contracts, all orders are subject to the current version of the "General Terms and Conditions of Würth Elektronik eiSos Group", last version available at www.we-online.com.

8 Legal notice

Exclusion of liability

Würth Elektronik eiSos GmbH & Co. KG considers the information in this document to be correct at the time of publication. However, Würth Elektronik eiSos GmbH & Co. KG reserves the right to modify the information such as technical specifications or functions of its products or discontinue the production of these products or the support of one of these products without any written announcement or notification to customers. The customer must make sure that the information used corresponds to the latest published information. Würth Elektronik eiSos GmbH & Co. KG does not assume any liability for the use of its products. Würth Elektronik eiSos GmbH & Co. KG does not grant licenses for its patent rights or for any other of its intellectual property rights or third-party rights.

Notwithstanding anything above, Würth Elektronik eiSos GmbH & Co. KG makes no representations and/or warranties of any kind for the

provided information related to their accuracy, correctness, completeness, usage of the products and/or usability for customer applications. Information published by Würth Elektronik eiSos GmbH & Co. KG regarding third-party products or services does not constitute a license to use such products or services or a warranty or endorsement thereof.

Suitability in customer applications

The customer bears the responsibility for compliance of systems or units, in which Würth Elektronik eiSos GmbH & Co. KG products are integrated, with applicable legal regulations. Customer acknowledges and agrees that it is solely responsible for compliance with all legal, regulatory and safety-related requirements concerning its products, and any use of Würth Elektronik eiSos GmbH & Co. KG components in its applications, notwithstanding any applications-related information or support that may be provided by Würth Elektronik eiSos GmbH & Co. KG. Customer represents and agrees that it has all the necessary expertise to create and implement safeguards which anticipate dangerous consequences of failures, monitor failures and their consequences lessen the likelihood of failures that might cause harm and take appropriate remedial actions. The customer will fully indemnify Würth Elektronik eiSos GmbH & Co. KG and its representatives against any damages arising out of the use of any Würth Elektronik eiSos GmbH & Co. KG components in safety-critical applications.

Trademarks

AMBER wireless is a registered trademark of Würth Elektronik eiSos GmbH & Co. KG. All other trademarks, registered trademarks, and product names are the exclusive property of the respective owners.

Usage restriction

Würth Elektronik eiSos GmbH & Co. KG products have been designed and developed for usage in general electronic equipment only. This product is not authorized for use in equipment where a higher safety standard and reliability standard is especially required or where a failure of the product is reasonably expected to cause severe personal injury or death, unless the parties have executed an agreement specifically governing such use. Moreover, Würth Elektronik eiSos GmbH & Co. KG products are neither designed nor intended for use in areas such as military, aerospace, aviation, nuclear control, submarine, transportation (automotive control, train control, ship control), transportation signal, disaster prevention, medical, public information network etc. Würth Elektronik eiSos GmbH & Co. KG must be informed about the intent of such usage before the design-in stage. In addition, sufficient reliability evaluation checks for safety must be performed on every electronic component, which is used in electrical circuits that require high safety and reliability function or performance. By using Würth Elektronik eiSos GmbH & Co. KG products, the customer agrees to these terms and conditions.

9 License terms

These License terms will take effect upon the purchase and usage of the Würth Elektronik eiSos GmbH & Co. KG wireless connectivity products. You hereby agree that these license terms are applicable to the product and the incorporated software, firmware and source codes (collectively, "Software") made available by Würth Elektronik eiSos in any form, including but not limited to binary, executable or source code form. The software included in any Würth Elektronik eiSos wireless connectivity product is purchased to you on the condition that you accept the terms and conditions of these license terms. You agree to comply with all provisions under these license terms.

Limited license

Würth Elektronik eiSos hereby grants you a limited, non-exclusive, non-transferable and royalty-free license to use the software and under the conditions that will be set forth in these license terms. You are free to use the provided software only in connection with one of the products from Würth Elektronik eiSos to the extent described in these license terms. You are entitled to change or alter the source code for the sole purpose of creating an application embedding the Würth Elektronik eiSos wireless connectivity product. The transfer of the source code to third parties is allowed to the sole extent that the source code is used by such third parties in connection with our product or another hardware provided by Würth Elektronik eiSos under strict adherence of these license terms. Würth Elektronik eiSos will not assume any liability for the usage of the incorporated software and the source code. You are not entitled to transfer the source code in any form to third parties without prior written consent of Würth Elektronik eiSos.

You are not allowed to reproduce, translate, reverse engineer, decompile, disassemble or create derivative works of the incorporated software and the source code in whole or in part. No more extensive rights to use and exploit the products are granted to you.

Usage and obligations

The responsibility for the applicability and use of the Würth Elektronik eiSos wireless connectivity product with the incorporated firmware in a particular customer design is always solely within the authority of the customer. Due to this fact, it is up to you to evaluate and investigate, where appropriate, and to decide whether the device with the specific product characteristics described in the product specification is valid and suitable for your respective application or not.

You are responsible for using the Würth Elektronik eiSos wireless connectivity product with the incorporated firmware in compliance with all applicable product liability and product safety laws. You acknowledge to minimize the risk of loss and harm to individuals and bear the risk for failure leading to personal injury or death due to your usage of the product.

Würth Elektronik eiSos' products with the incorporated firmware are not authorized for use in safety-critical applications, or where a failure of the product is reasonably expected to cause severe personal injury or death. Moreover, Würth Elektronik eiSos' products with the incorporated firmware are neither designed nor intended for use in areas such as military, aerospace, aviation, nuclear control, submarine, transportation (automotive control, train control, ship control), transportation signal, disaster prevention, medical, public information network etc. You shall inform Würth Elektronik eiSos about the intent of such usage before design-in stage. In certain customer applications requiring a very high level of safety and in which the malfunction or failure of an electronic component could endanger human life or health, you must ensure to have all necessary expertise in the safety and regulatory ramifications of your applications. You acknowledge and agree that you are solely responsible for all legal, regulatory and safety-related requirements concerning your products and any use of Würth Elektronik eiSos' products with the incorporated firmware in such safety-critical applications, notwithstanding any applications-related information or support that may be provided by Würth Elektronik eiSos. **YOU SHALL INDEMNIFY WÜRTH ELEKTRONIK EISOS AGAINST ANY DAMAGES ARISING OUT OF THE USE OF WÜRTH ELEKTRONIK EISOS' PRODUCTS WITH THE INCORPORATED FIRMWARE IN SUCH SAFETY-CRITICAL APPLICATIONS.**

Ownership

The incorporated firmware created by Würth Elektronik eiSos is and will remain the exclusive property of Würth Elektronik eiSos.

Firmware update(s)

You have the opportunity to request the current and actual firmware for a bought wireless connectivity product within the time of warranty. However, Würth Elektronik eiSos has no obligation to update a modules firmware in their production facilities, but can offer this as a service on request. The upload of firmware updates falls within your responsibility, e.g. via ACC or another software for firmware updates. Firmware updates will not be communicated automatically. It is within your responsibility to check the current version of a firmware in the latest version of the product manual on our website. The revision table in the product manual provides all necessary information about firmware updates. There is no right to be provided with binary files, so called "firmware images", those could be flashed through JTAG, SWD, Spi-Bi-Wire, SPI or similar interfaces.

Disclaimer of warranty

THE FIRMWARE IS PROVIDED "AS IS". YOU ACKNOWLEDGE THAT WÜRTH ELEKTRONIK EISOS MAKES NO REPRESENTATIONS AND WARRANTIES OF ANY KIND RELATED TO, BUT NOT LIMITED TO THE NON-INFRINGEMENT OF THIRD PARTIES' INTELLECTUAL PROPERTY RIGHTS OR THE MERCHANTABILITY OR FITNESS FOR YOUR INTENDED PURPOSE OR USAGE. WÜRTH ELEKTRONIK EISOS DOES NOT WARRANT OR REPRESENT THAT ANY LICENSE, EITHER EXPRESS OR IMPLIED, IS GRANTED UNDER ANY PATENT RIGHT, COPYRIGHT, MASK WORK RIGHT, OR OTHER INTELLECTUAL PROPERTY RIGHT RELATING TO ANY COMBINATION, MACHINE, OR PROCESS IN WHICH THE WÜRTH ELEKTRONIK EISOS' PRODUCT WITH THE INCORPORATED FIRMWARE IS USED. INFORMATION PUBLISHED BY WÜRTH ELEKTRONIK EISOS REGARDING THIRD-PARTY PRODUCTS OR SERVICES DOES NOT CONSTITUTE A LICENSE FROM WÜRTH ELEKTRONIK EISOS TO USE SUCH PRODUCTS OR SERVICES OR A WARRANTY OR ENDORSEMENT THEREOF.

Limitation of liability

Any liability not expressly provided by Würth Elektronik eiSos shall be disclaimed.

You agree to hold us harmless from any third-party claims related to your usage of the Würth Elektronik eiSos' products with the incorporated firmware, software and source code. Würth Elektronik eiSos disclaims any liability for any alteration, development created by you or your customers as well as for any combination with other products.

Applicable law and jurisdiction

Applicable law to these license terms shall be the laws of the Federal Republic of Germany. Any dispute, claim or controversy arising out of or relating to these license terms shall be resolved and finally settled by the court competent for the location of Würth Elektronik eiSos registered office.

Severability clause

If a provision of these license terms is or becomes invalid, unenforceable or null and void, this shall not affect the remaining provisions of the terms. The parties shall replace any such provisions with new valid provisions that most closely approximate the purpose of the terms.

Miscellaneous

Würth Elektronik eiSos reserves the right at any time to change these terms at its own discretion. It is your responsibility to check at Würth Elektronik eiSos homepage for any updates. Your continued usage of the products will be deemed as the acceptance of the change.

We recommend you to be updated about the status of new firmware and software, which is available on our website or in our data sheet and manual, and to implement new software in your device where appropriate.

By ordering a product, you accept these license terms in all terms.

List of Figures

1	Stephano-I EV-Board	4
2	Block diagram	7
3	Orthosie-I: Default configuration of jumpers	8
4	Stephano-I: Default configuration of jumpers	9
5	Connectors	11
6	Circuit diagram (part 1)	16
7	Circuit diagram (part 2)	17
8	Assembly diagram	18
9	Top layer	19
10	Bottom layer	20
11	Lot number structure	22

List of Tables

1	Compatibility	4
2	Order codes	4
3	Content Orthosie-I EV-Kit	5
4	Content Stephano-I EV-Kit	5
5	Jumper JP1	10
6	Jumper JP2	10
7	Connector overview	12
8	Example baud rates	15
9	Lot number details	22



Contact

Würth Elektronik eiSos GmbH & Co. KG
Division Wireless Connectivity & Sensors

Max-Eyth-Straße 1
74638 Waldenburg
Germany

Tel.: +49 651 99355-0
Fax.: +49 651 99355-69
www.we-online.com/wireless-connectivity

WÜRTH ELEKTRONIK MORE THAN YOU EXPECT