

# ePDM 70-150

Power Distribution Controller



The ePDM 70-150 is an electronic power distribution controller that can control a variety of loads. It has a large number of outputs up to 35 A. The controller is designed to meet the requirements of a modern vehicle and, in addition to powering the loads, allows also the integration of numerous diagnostic functions. With ePDM 70-150, different wake-up scenarios can be implemented. The „Always-ON“ outputs provide power to modules, such as a telematics module, even when the ePDM is switched off.

The controller communicates via CAN bus and is fully programmable. The WEcontrol Designer provides a powerful programming environment. For system protection, e.g. against open load or overcurrent, you can implement diagnostic functions and configure the outputs using “fuse-like” function blocks.

General information	
Housing	Standard ePDM
Connectors	1 x Powerelement M8 1 x LeavySeal 31 pins, Coding E 1 x LeavySeal 39 pins; Coding F
Dimensions	240 x 180 x 50 mm
Weight	~ 1 kg
Operating temperature	-30 °C to +85 °C
Storage temperature	-40 °C to +85 °C
Operating range	9 to 16 V
Pre-fusing (recommended)	200 A main supply
Max. current	150 A at 70 °C; 120 A at 85 °C; 200 A short term
Current consumption	Active (no output) < 100 mA Sleep mode < 3 mA (all outputs off)
Processor	NXP S32K Cortex M4 32 bit
Clock frequency	80 MHz
Flash memory	2 MB
RAM	256 kB
FRAM	2 kB
Ingress protection	IP6K7 / IP 6K9K
CAN Bus	
	<b>2 CAN ports</b>
Acc. ISO 11898-2 High speed	83, 100, 125, 250, 500, 1000 kBit /s (500 kb/s default speed)

Inputs / Outputs overview		
1	Vref 5 V	max 200 mA / switchable
3	Analogue inputs	0 – 5 V
2	Analogue inputs	0 – 20 mA / 0 – 10 V
4	Analogue inputs	0 – 16 V
2	CAN interface	CAN 2.0 high speed
7	Digital high inputs	2x Wake up high active
3	Digital low inputs	2x Wake up low active
3	Frequency input	or digital input
4	Digital outputs AOn	max load 2 x 3 A, 2 x 6 A always on
2	Digital outputs 300 mA	sinking outputs (LSD)
10	Digital outputs 3 A	max load 3 A
10	Digital outputs 6 A	max load 6 A
8	Digital outputs 9 A	max load 9 A
3	Digital outputs 35 A	max load 35 A
1	Full Bridge 4 A	max load 4 A

Input details	
<b>Analogue inputs</b>	<b>3 x 0 – 5 V DC</b>
Input voltage range	0 – 5.2 V DC
Resolution	12 bit
Input impedance	77 KΩ
Switchable pull up	10 KΩ to 5 V
<b>Analogue inputs</b>	<b>2 x 0 – 10 V / 0 – 20 mA</b>
Input range	0 – 11.2 V or 0 – 30 mA
Resolution	12 bit
Input impedance	41 KΩ for voltage mode
Switchable pull down	~340 Ω for current mode
<b>Analogue inputs</b>	<b>4 x 0 – 16 V</b>
Input	0 – 16 V
Resolution	12 bit
Input impedance	37 KΩ
<b>Digital high inputs*</b>	<b>7 x</b>
Input voltage	0 – 16 V
Switch-on / off level	5.7 V – 2.5 V
Input impedance	min 34 KΩ
Non wake-up Dig IN are disconnected in sleep mode	
<b>Digital low inputs*</b>	<b>3x</b>
Input voltage	0 – 16 V
Switch-on / off level	2 V – 3 V
Pull-up impedance	115 K to 3V3

\*Two DI high and two DI low are wake-up inputs

Input details	
<b>Frequency inputs</b>	<b>3 x</b>
Input voltage	0 – 16 V DC
Max. frequency	15 KHz / 10 to 90 %
Switch-on / off level	5.7 – 2.5 V
Input impedance	min 34 KΩ

Status LED	
Color	3 colors LED (R / G / B)
Function	Free programmable status LED
Visibility	Through transparent window

Protections	
Overvoltage	CPU shutdown / transil diode
Over current	Overcurrent programmable per software
Short to ground / battery	All inputs referred to ground HSD outputs protected by internal thermal protection (SmartFET)

Output details	
<b>Digital outputs 35 A</b>	3 x high side
Load current	max 35 A
Diagnostic current sense, PWM, max feedback range 60 A	
<b>Digital outputs 9 A</b>	8 x high side
Load current	max 9 A
Diagnostic current sense, PWM, max feedback range 16.1 A	
<b>Digital outputs 6 A</b>	12 x high side
Load current	max 6 A
Diagnostic current sense, half with PWM, max feedback range 13.25 A	
<b>Digital outputs 3 A</b>	12 x high side
Load current	max 3 A
Diagnostic current sense, half with PWM, max feedback range 6.25 A	
<b>Digital output 4 A</b>	1 x full bridge
Load current	max 4 A
Diagnostic current sense, PWM, max feedback range 7.7 A	
<b>Digital outputs low side</b>	2 x low side
Load current	max 300 mA

Test standards and regulations		
E1	UN/ECE-R10	ESD Immunity Radiated Immunity Conducted Immunity Magnetic Immunity Conducted Emissions Radiated Emissions
Electrical tests	ISO 7637-2	Impulse 1, Impulse 2a, Impulse 2b, Impulse 3a, Impulse 3b, Impulse 4, Impulse 5
Environmental tests	EN 60068-2-30 EN 60068-2-78 EN 60068-2-52	
Mechanical tests	ISO 16750-3 EN 60068-2-6 ISO 16750-3	

Intend of use and disclaimer	
High side outputs	Although the outputs are protected against polarity inversion, they are not intended to be powered by another voltage when the main supply is disconnected. This should be avoided at all times.
35 A high side output & main ground	Due to the internal protection, we recommend using 6 mm <sup>2</sup> wires on the four 6.3 mm pins.
LED usage	The LED will light orange during the boot process, once the CPU has started the LED behavior / color must be defined in the software application.
Temperature sensors	The temperature sensors are only an indication and are here to give a rough idea about the status of the product, no specific behavior has been designed in relation to these sensors value. The final application is free to define some behaviors based on these temperature sensors (NTC resistance type), we suggest to start taking measures when one of the 3 sensors reaches max. 100 °C.
Vmain	The main supply voltage is connected to all outputs. It should be protected / fused outside the unit.
Inductive loads	When supplying inductive loads, the rated current should be reduced by half to ensure correct protection, freewheeling diodes should be fitted as close as possible to the load and the cable length should be kept as short as possible (preferably less than 5 m). The product does not have an internal freewheeling diode.
Inrush current	Inrush current evaluation underway, datasheet will be updated with more data when available
Internal fuses	Each output is internally protected by a SMD fuse, this is for extra safety in case of emergency, they are oversized and the high side outputs will protect the system much faster than the SMD fuse. Output : 35 A (50 A fuse) / 9 A (20 A fuse) / 6 A (20 A fuse) / 3 A (15 A fuse) / 4 A (15 A fuse)
PWM outputs	When used in PWM mode, only the 9 A and 35 A outputs provide a representative average current. The 3 A and 6 A outputs do not provide an effective current reading in PWM mode. In PWM mode, only one frequency can be set per output type, but different duty cycles. Frequencies given for 90 % duty cycle / 50 % rated load 35 A (max 90 Hz) / 9 A (max 200 Hz) / 6 A (max 500 Hz) / 3 A (max 500 Hz) / H-bridge (max 1 KHz). If different frequencies are set, the first output activated will set the frequency for the whole output type until they are all switched off. It is only possible to change the frequency for one type if no output or only one output is activated.

# ePDM 70-150

## Power Distribution Controller

Software possibilities (example)	
Highs side outputs	On the high side, the current feedback information can be used to detect short circuits or overloads, and actions can then be programmed in the main application.
Wake up	4 digital inputs (2 high active, 2 low active) are always present to activate/wake the unit. All inputs must be in "Off" state for the unit to enter sleep mode. Sleep mode must be programmed/requested in the application.
Fuse like behavior	The programming environment provides several advanced function blocks for output behavior calibration and diagnostics. Please note the following current update rates for the outputs: 35 A: ~200 ms / 9 A: ~200 ms / 6 & 3 A: ~100 ms
Always ON outputs	The CPU must be started at least once to configure the outputs, they are not immediately activated when the KL30 is first connected. As soon as the device is powered up, they behave as normal outputs. When the unit is switched off, the 4 outputs retain the last programmed state. If they are off and you want to activate them, you must activate them in your shutdown routine.

### Dimensions

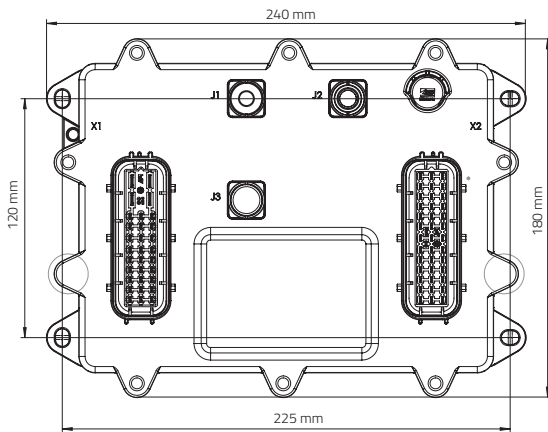

### Mounting

Max. torque	
M8 power supply	9 Nm max.
M6 x 4 fixing screws	11 Nm max.
Vertical mounting recommended but not mandatory Connectors facing down (see left picture)	

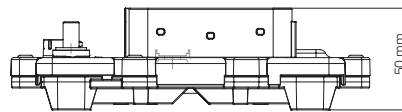

### Hardware map

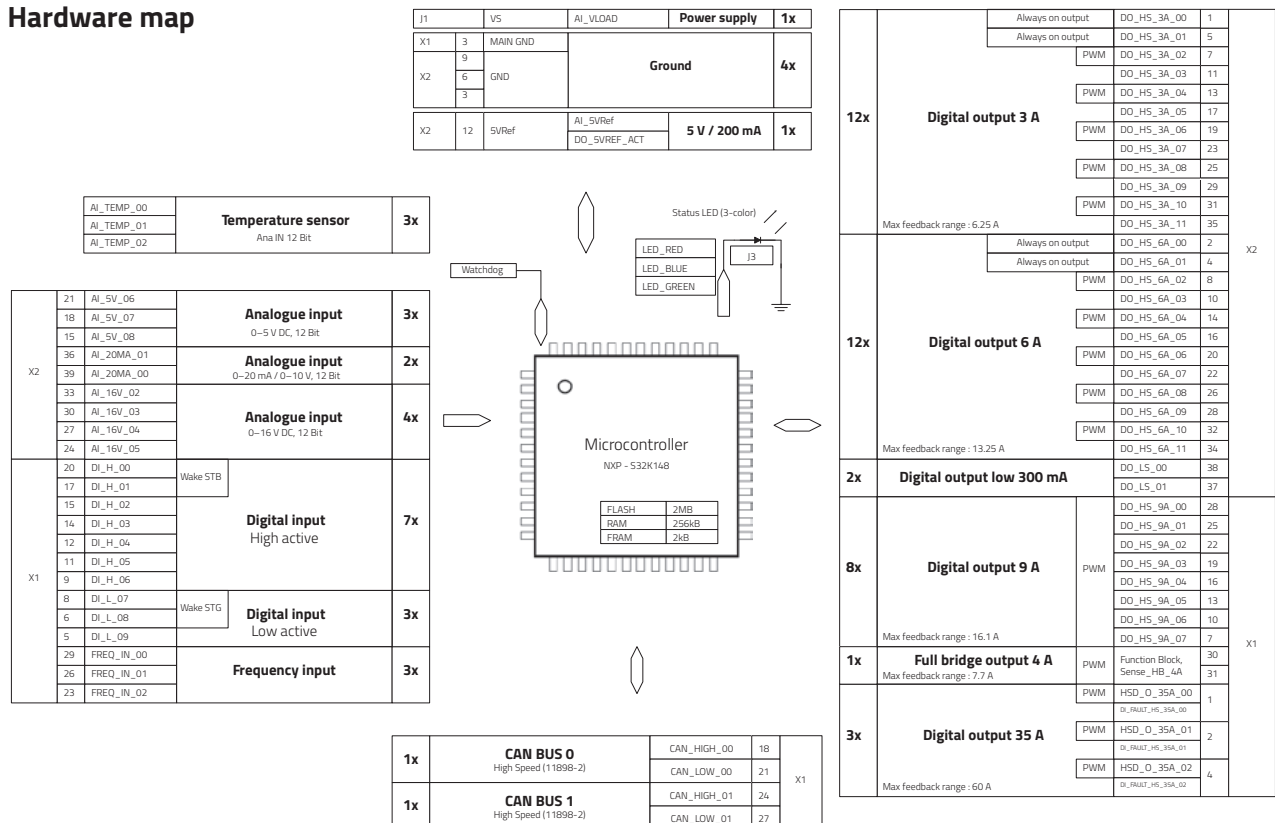

### Pin assignment

X1 Connector		
Pin	Description	Function
1	HSD_O_35A_0	Digital output 35 A
2	HSD_O_35A_1	Digital output 35 A
3	GND	Ground (main)
4	HSD_O_35A_2	Digital output 35 A
5	DI_L_09	Digital input low
6	DI_L_08	Digital input low*
7	DO_HS_9A_07	Digital output 9 A
8	DI_L_07	Digital input low*
9	DI_H_06	Digital input high
10	DO_HS_9A_06	Digital output 9 A
11	DI_H_05	Digital input high
12	DI_H_04	Digital input high
13	DO_HS_9A_05	Digital output 9 A
14	DI_H_03	Digital input high
15	DI_H_02	Digital input high
16	DO_HS_9A_04	Digital output 9 A
17	DI_H_01	Digital input high*
18	CAN 0 H	CAN 0 CAN high**
19	DO_HS_9A_03	Digital output 9 A
20	DI_H_00	Digital input high*
21	CAN 0 L	CAN 0 CAN low**
22	DO_HS_9A_02	Digital output 9 A
23	FREQ_IN_02	Frequency input
24	CAN 1 H	CAN 1 CAN high
25	DO_HS_9A_01	Digital output 9 A
26	FREQ_IN_01	Frequency input
27	CAN 1 L	CAN 1 CAN low
28	DO_HS_9A_00	Digital output 9 A
29	FREQ_IN_00	Frequency input
30	HB_4A_0	Full bridge pin B
31	HB_4A_1	Full bridge pin A

X2 Connector		
Pin	Description	Function
1	DO_HS_3A_00	Digital output 3 A Aon***
2	DO_HS_6A_00	Digital output 6 A Aon***
3	GND	Ground
4	DO_HS_6A_01	Digital output 6 A Aon***
5	DO_HS_3A_01	Digital output 3 A Aon***
6	GND	Ground
7	DO_HS_3A_02	Digital output 3 A
8	DO_HS_6A_02	Digital output 6 A
9	GND	Ground
10	DO_HS_6A_03	Digital output 6A
11	DO_HS_3A_03	Digital output 3 A
12	5Vref	5 V reference voltage
13	DO_HS_3A_04	Digital output 3 A
14	DO_HS_6A_04	Digital output 6 A
15	AI_5V_08	Analogue input 0 – 5 V
16	DO_HS_6A_05	Digital output 6 A
17	DO_HS_3A_05	Digital output 3 A
18	AI_5V_07	Analogue input 0 – 5 V
19	DO_HS_3A_06	Digital output 3 A
20	DO_HS_6A_06	Digital output 6 A
21	AI_5V_06	Analogue input 0 – 5 V
22	DO_HS_6A_07	Digital output 6 A
23	DO_HS_3A_07	Digital output 3 A
24	AI_16V_05	Analogue input 0 – 16 V
25	DO_HS_3A_08	Digital output 3 A
26	DO_HS_6A_08	Digital output 6 A
27	AI_16V_04	Analogue input 0 – 16 V
28	DO_HS_6A_09	Digital output 6 A
29	DO_HS_3A_09	Digital output 3 A
30	AI_16V_03	Analogue input 0 – 16 V
31	DO_HS_3A_10	Digital output 3 A
32	DO_HS_6A_10	Digital output 6 A
33	AI_16V_02	Analogue input 0 – 16 V
34	DO_HS_6A_11	Digital output 6 A
35	DO_HS_3A_11	Digital output 3 A
36	AI_20MA_01	Analogue input 0 – 20 mA
37	DO_LS_01	Digital low 300 mA
38	DO_LS_00	Digital low 300 mA
39	AI_20MA_00	Analogue input 0 – 20 mA

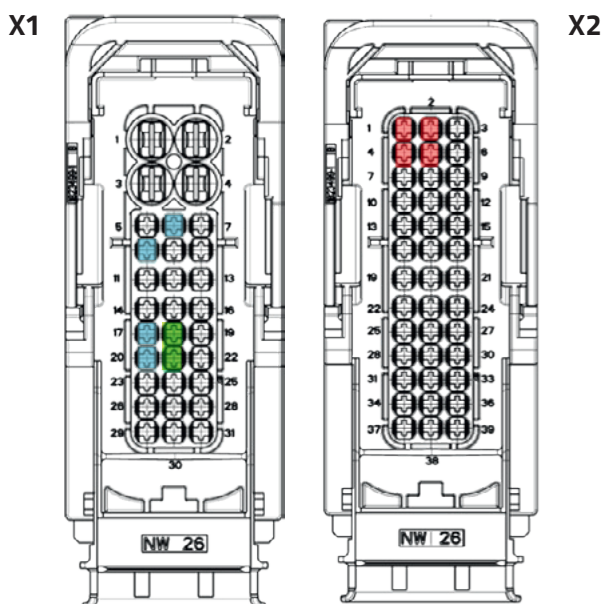

- \* Wake up input
- \*\* CAN 0: UDS programming interface
- \*\*\* Always on output

### Programming with WEcontrol Designer

WEcontrol Designer is the advanced programming environment from Würth Elektronik ICS. The set of powerful text and graphical editors for IEC-61131-3 languages supports the following programming types:

- Sequential Flow Chart (SFC)
- Function Block Diagram (FBD)
- Ladder Diagram (LD)
- Structured Text (ST)



The WEcontrol Designer also offers a wide range of features such as:

- Optimised application creation
- Simulation and online data access / modification via CAN bus
- Automated language conversion
- User Defined Function Blocks (UDFB) for specific / repetitive functions
- Graphical I/O mapping and configuration
- Automated HTML project documentation
- Import of CAN communication database from Vector and Peak systems
- Easy creation of graphical debug interfaces (based on the application)

### WEcontrol Designer Try & Buy Kit

Use our WEcontrol Designer software development tool and Try & Buy Kit to independently program the functions you want to use.



### Order Information

Available references	
ICS-103592	ePDM 70-150

Mating connectors	
6-1718321-3	Leavy Seal Housing 39 way AMP MCP 2.8 (Brown) Coding F (S03433)
1-1564297-6	Leavy Seal Housing 31 way AMP MCP 2.8/6.3 (Burgundy) Coding E (S03406)
1418882-1	Cover
828922-1	Blinds 2.8 (V15001)
1719043-1	Blinds 6.3 (V15002)
1-968857-1	MCP 2.8 contacts (V15004)
1241418-4	MCP 6.3 contacts (V15005)

This item is a standard product, please consider the relevant datasheet notes. The user is responsible for the product's functionality in its purposed system environment. Technical content may be modified and changed by Würth Elektronik ICS GmbH & Co. KG without any notice.

For more information write us an e-mail [ics@we-online.com](mailto:ics@we-online.com), call **+49 7940 9810-0** or visit us at [www.we-online.com/ics](http://www.we-online.com/ics)

**Würth Elektronik ICS GmbH & Co. KG**  
**Intelligent Power & Control Systems**  
Gewerbepark Waldzimmern · Würthstraße 1  
74676 Niedernhall · Germany  
Tel.: +49 7940 9810-0 · Fax +49 7940 9810-1099  
[ics@we-online.com](mailto:ics@we-online.com) · [www.we-online.com/ics](http://www.we-online.com/ics)