

DIGITAL WE DAYS

2023



EMC PRECOMPLIANCE
MEASUREMENTS AND
OPTIMIZATIONS

WÜRTH ELEKTRONIK MORE THAN YOU EXPECT

TODAY'S SPEAKERS



PRESENTATION

Muhammad Ahsan Abbasi
EMC-Laboratory Engineer



MODERATION

Markus Eberle
Marketing Department

INFORMATION ABOUT THE WEBINAR

You are muted during the webinar.

However, you can ask us questions using the chat function.

Duration of the presentation 30 Min
Q&A: 10 – 15 Min

Any questions?
No problem! Email us digital-we-days@we-online.com

Please help us to optimize our webinars!
We are looking forward to your feedback.

On our channel Würth Elektronik Group
And on [Digital WE Days 2023 YouTube Playlist](#)



AGENDA

- Introduction to EMC
- Road to compliance
- Applicability of the EMCD 2014/30/EU
- EMC Measurements and Standards
- Placement of Input filter components: Design tip
- Würth Elektronik EMC Lab Service



INTRODUCTION TO EMC

What is EMC ?

Ability of an equipment or a system

- to function satisfactorily in its electromagnetic environment
- without introducing intolerable electromagnetic disturbances to anything in that environment.

LIVE AND LET OTHERS LIVE

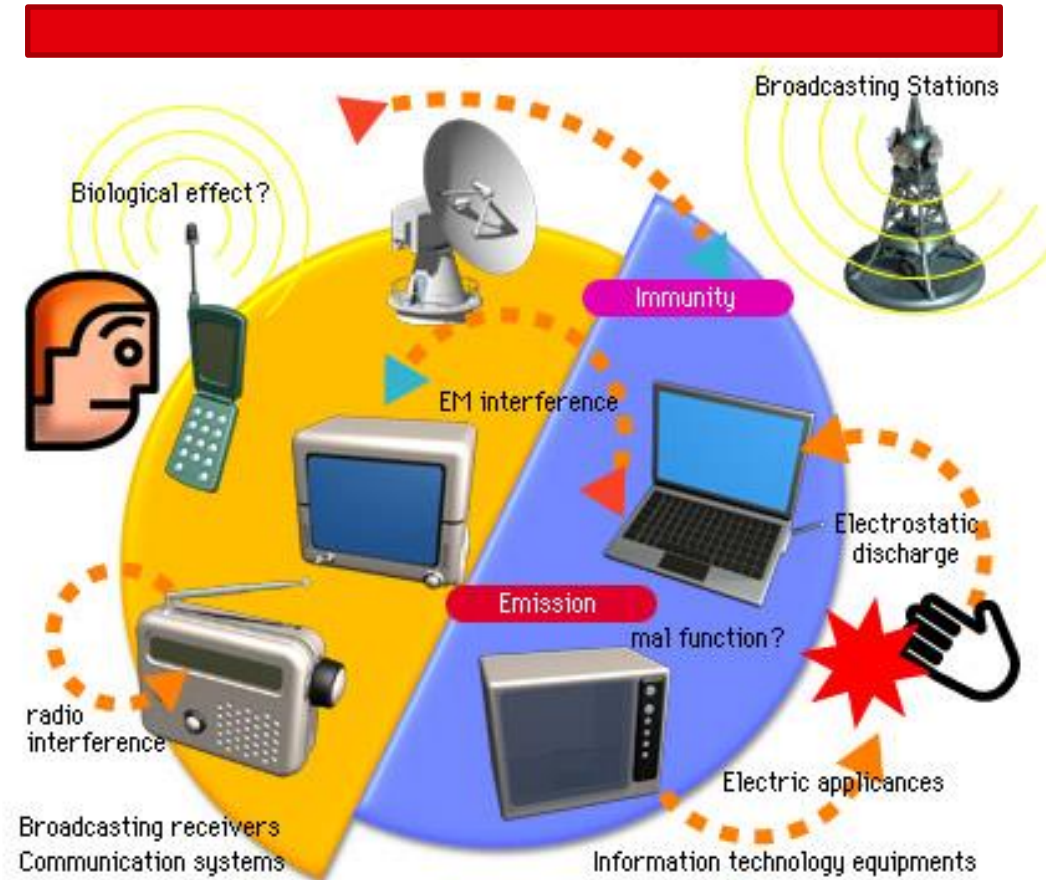

https://emc.nict.go.jp/general/images/img_general_e.jpg

INTRODUCTION TO EMC

New Approach / New Legislative Framework

NLF: Adopted in 2008

- Improve the internal market for goods
- Strengthen the conditions for placing a wide range of products on the EU market
- Measures to improve market surveillance and boost the quality of conformity assessments
- Clarifies the use of CE marking

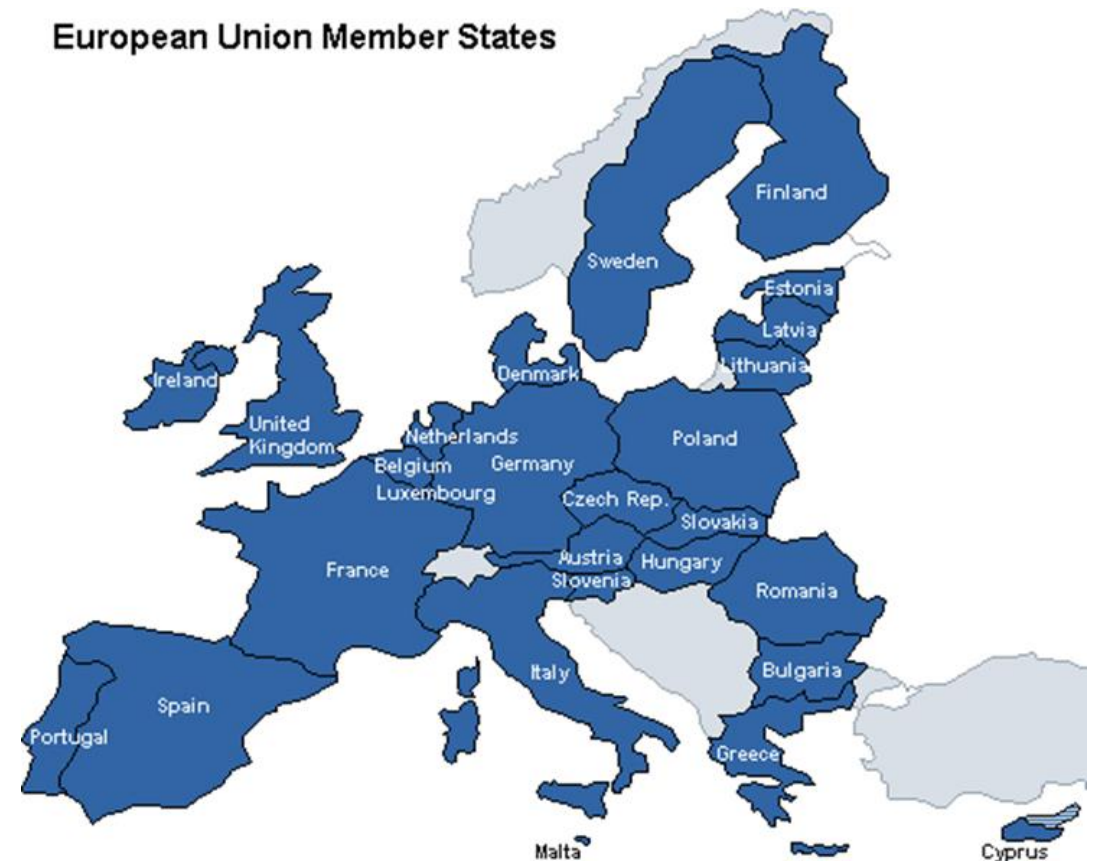

INTRODUCTION TO EMC

New Approach Directives

NLF →→→ 22 New Approach Directives

EMCD (Directive 2014/30/EU)

RED (Directive 2014/53/EU)

LVD (Directive 2014/35/EU)

-
-
-
-
-
-



EU-Konformitätserklärung <i>EU-Declaration of Conformity</i>	
Wireless Ladeplatte Ergopower PAD I & II	Wireless charging plate Ergopower PAD I & II
Art. 0827 940 991, 0827 940 992	
Wir erklären hiermit, dass die oben beschriebenen Ladeplatten übereinstimmen mit den Bestimmungen der EU-Richtlinien 2014/53/EU, 2011/65/EU, 2009/125/EG.	Herewith we declare that the above mentioned charging plates are manufactured in accordance with the requirements of Council Directive 2014/53/EU, 2011/65/EU, 2009/125/EC.
Die Ladeplatten entsprechen den harmonisierten Normen:	The charging plates correspond to the harmonised standards:
ETSI EN 301 489-1 V2.2.1 (2019-03) ETSI EN 301 489-3 V2.1.1 (2019-03) ETSI EN 303 417 V1.1.1 (2017-09) EN 50364:2010 EN 60950-1:2006+A11:2009+A1:2010+A12:2011+A2:2013 EN 55032:2015 EN 55035:2017 EN 61000-3-2:2014 EN 61000-3-3:2013 EN 62368-1:2014+A11:2017 (EU) 2019/1782	ETSI EN 301 489-1 V2.2.1 (2019-03) ETSI EN 301 489-3 V2.1.1 (2019-03) ETSI EN 303 417 V1.1.1 (2017-09) EN 50364:2010 EN 60950-1:2006+A11:2009+A1:2010+A12:2011+A2:2013 EN 55032:2015 EN 55035:2017 EN 61000-3-2:2014 EN 61000-3-3:2013 EN 62368-1:2014+A11:2017 (EU) 2019/1782
Würth International AG Aspermontstrasse 1 CH-7004 Chur SWITZERLAND	
	 Gerd Rossler Managing Director
Chur, 12.05.2020	 Tommy Neining Product Manager Lighting / Installation

ROAD TO COMPLIANCE

Role of Harmonised standards in achieving compliance

All essential requirements (ESRs) given in legislation

Applicable essential requirements to be complied

Specifications to comply with applicable ESRs



[Publications Office \(europa.eu\)](https://publications-office.europa.eu)

EXAMPLE

Essential requirements defined in EMC Directive 2014/30/EU

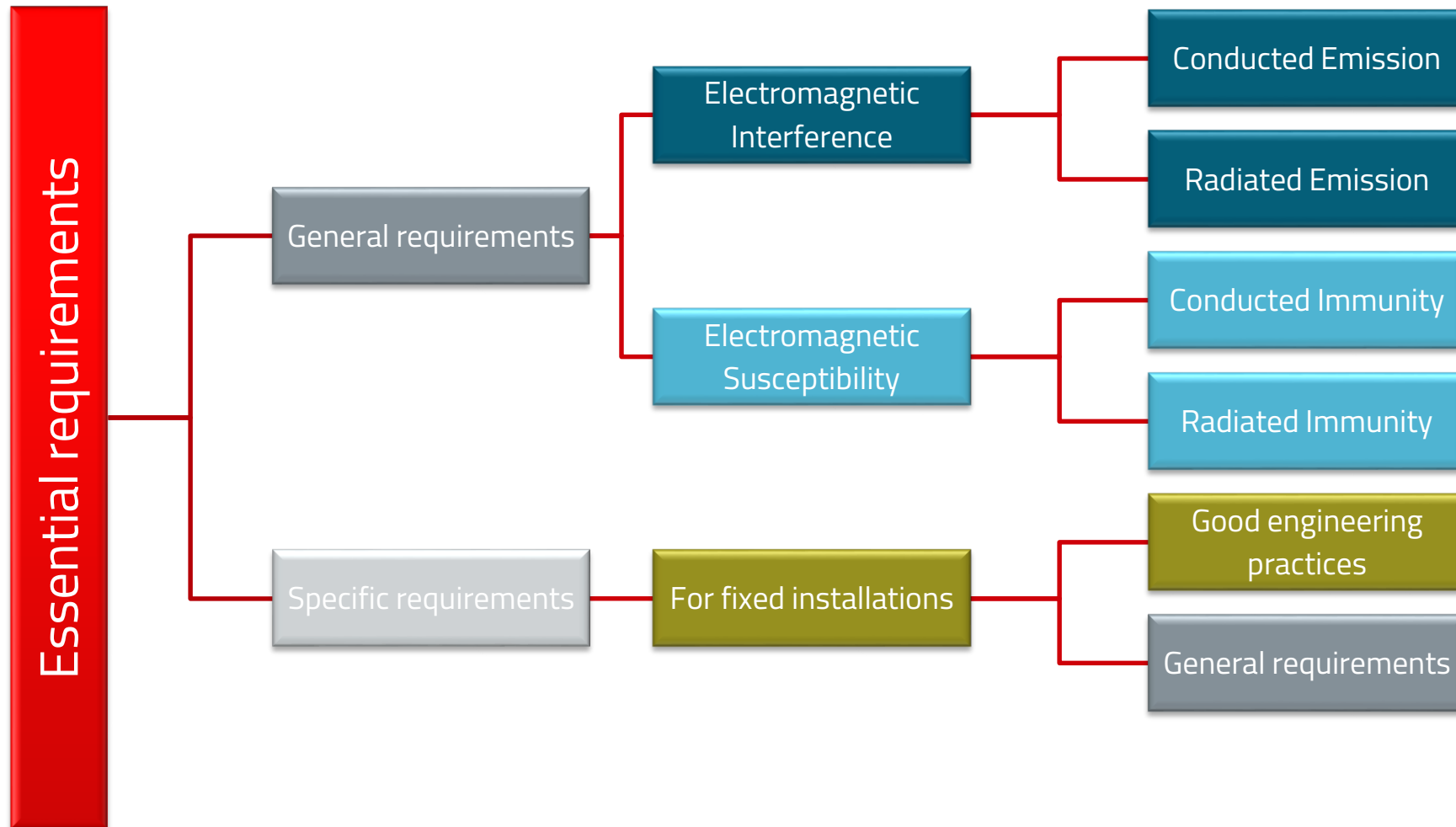

APPLICABILITY OF THE EMCD

Which provisions should be applied?

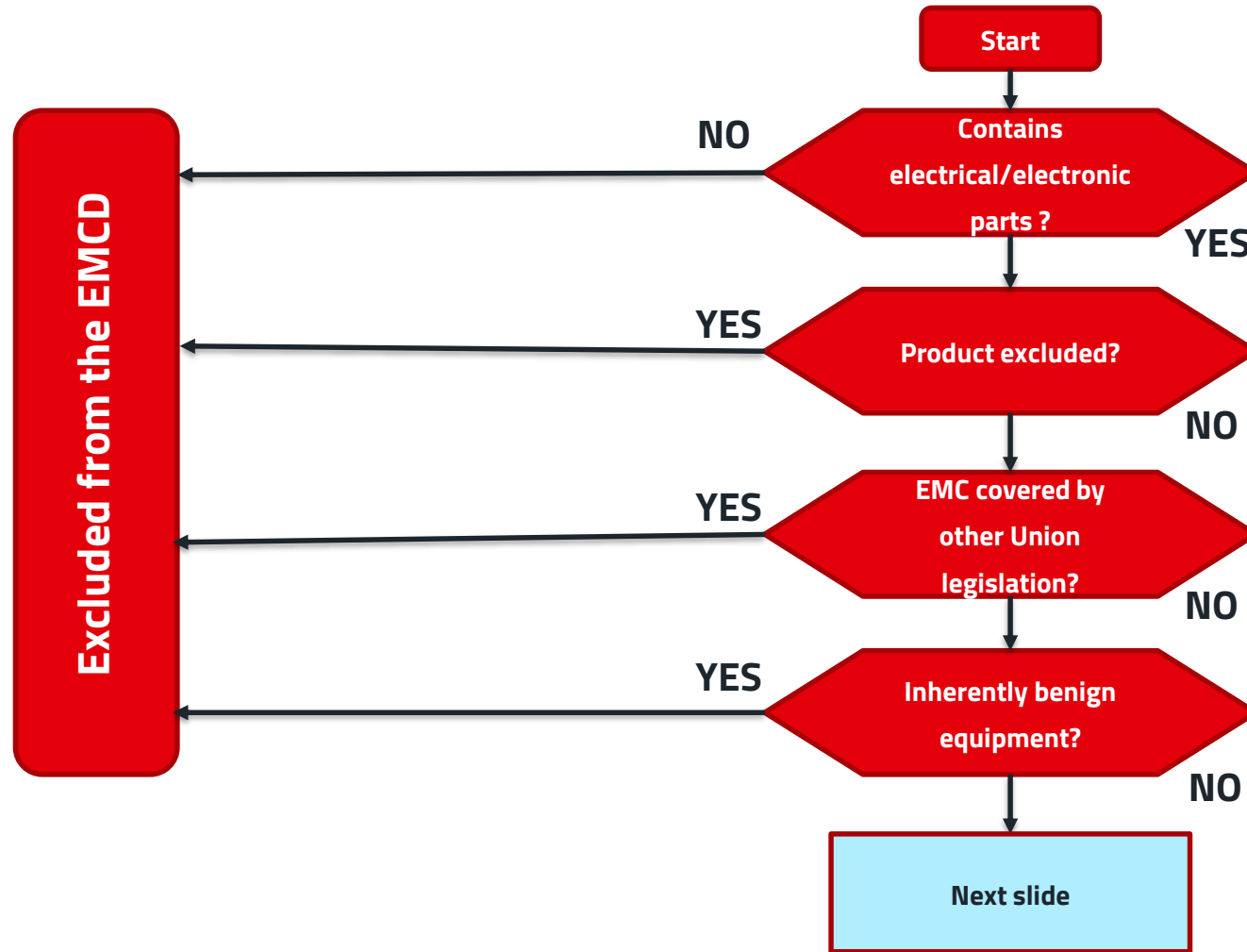

19 December 2018
Guide for the EMCD (Directive 2014/30/EU)A

APPLICABILITY OF THE EMCD

Which provisions should be applied?

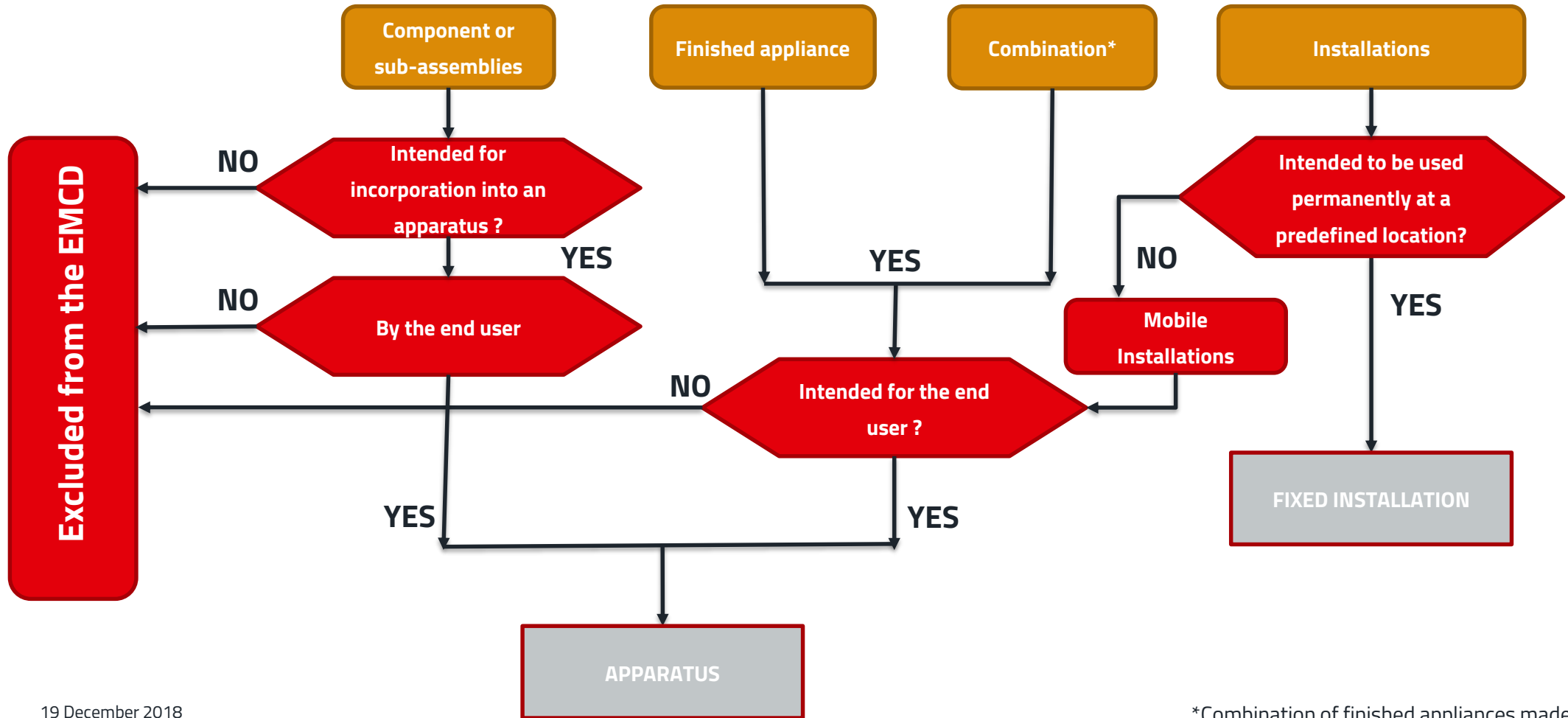

19 December 2018
Guide for the EMCD (Directive 2014/30/EU)A

*Combination of finished appliances made commercially available as a single unit

APPLICABILITY OF THE EMCD

Which provisions should be applied?

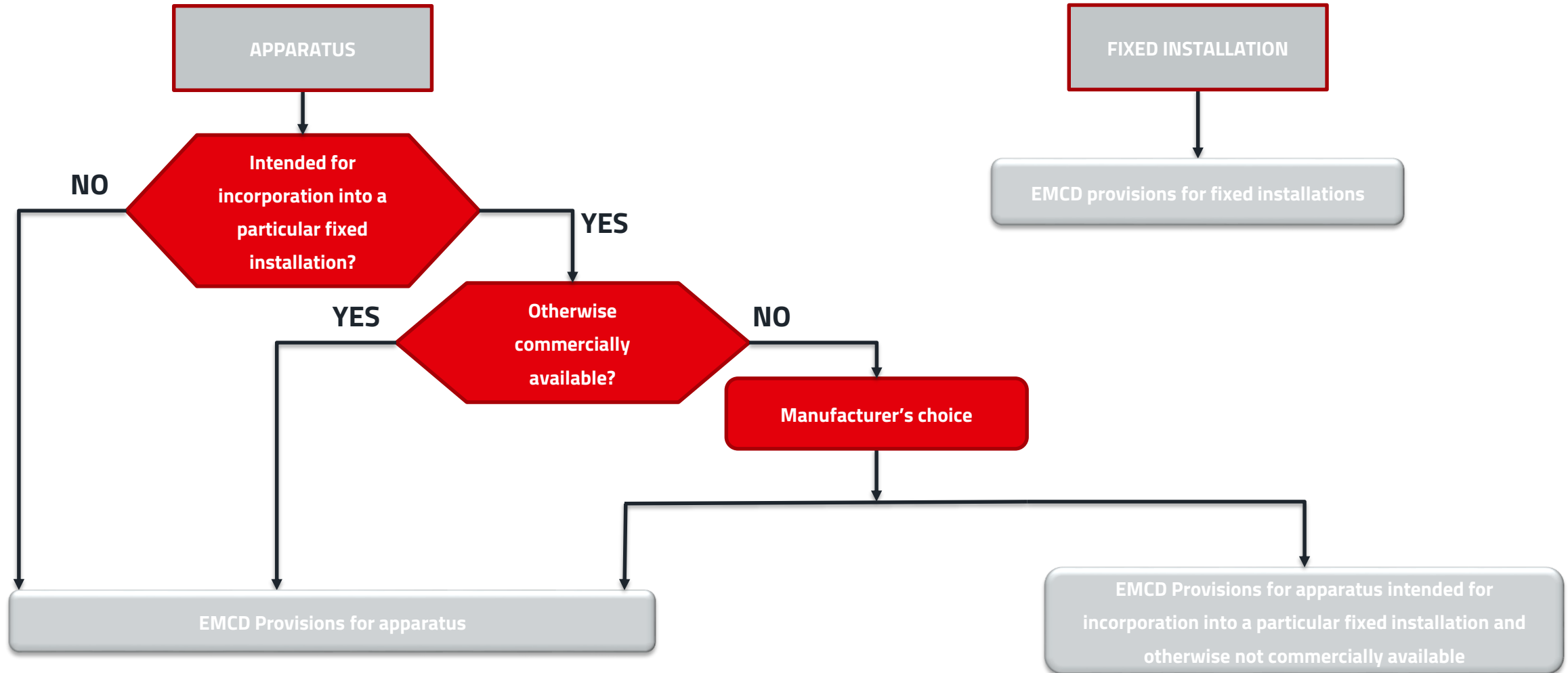

19 December 2018
Guide for the EMCD (Directive 2014/30/EU)A

CONFORMITY ASSESSMENT

Conformity assessment procedure for apparatus

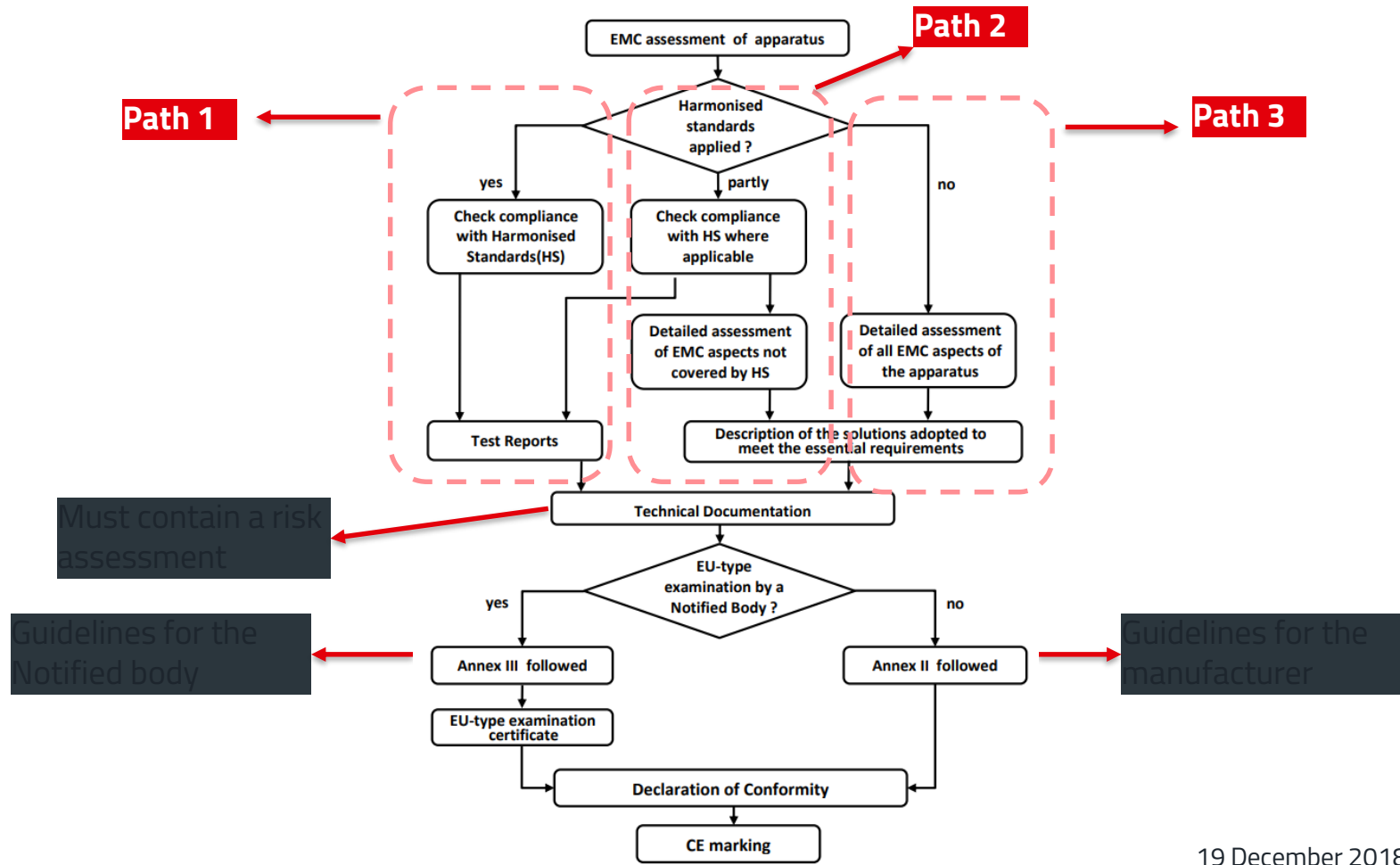

19 December 2018
Guide for the EMCD (Directive 2014/30/EU)

EMC MEASUREMENTS

EMC Pre-compliance measurements

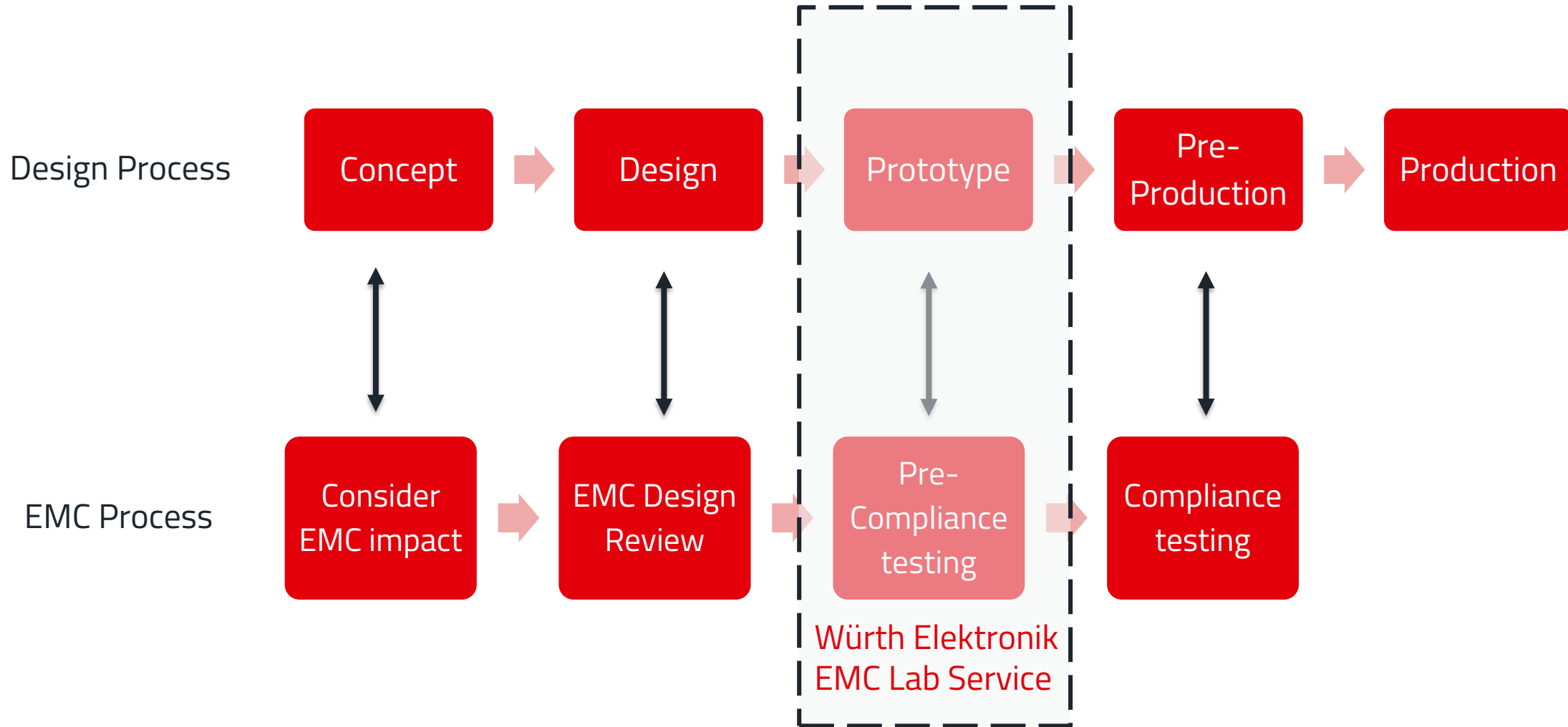

EMC STANDARDS

Classification

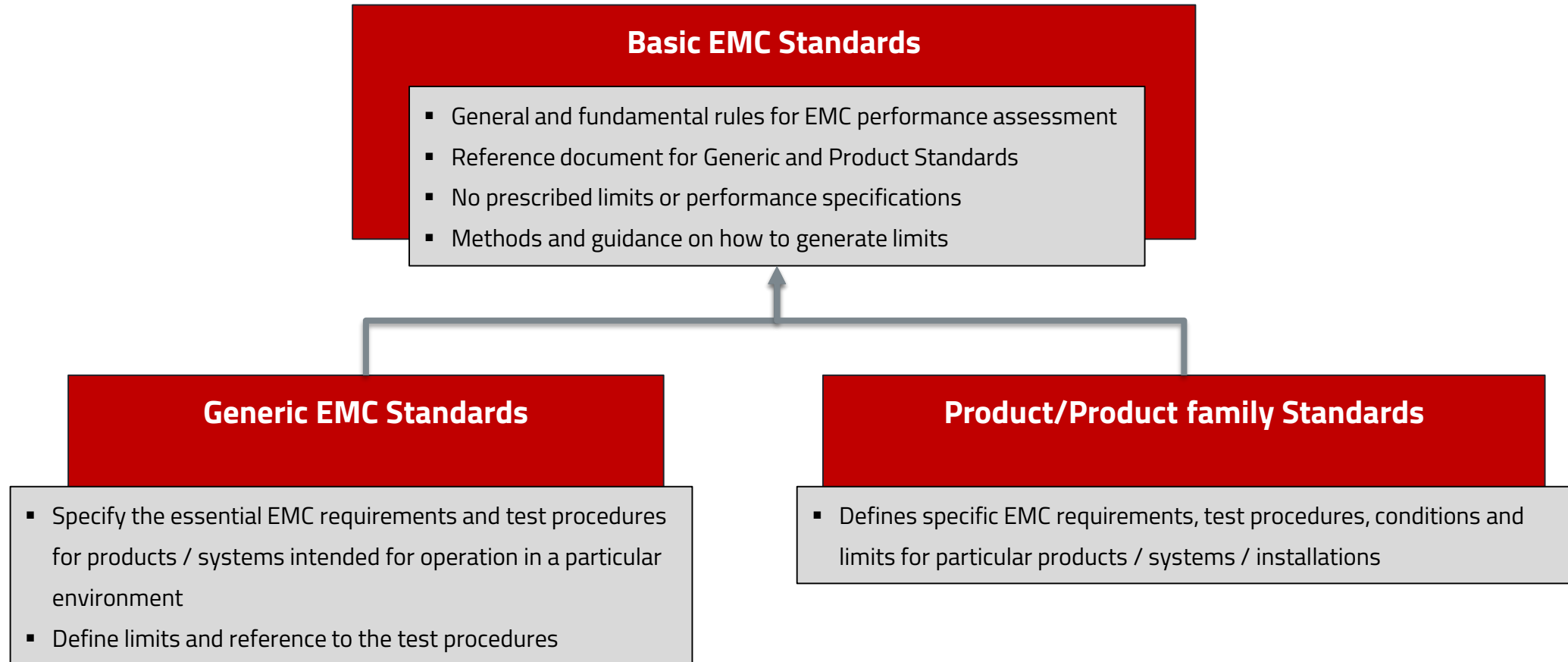

INTRODUCTION TO EMC

DC DC Buck converter example

MagI³C power module
WE PN: 171032401

6-24 VIN
5-24 VOUT
I_{OUT} : 0-3 A
f_{sw} : 500 kHz

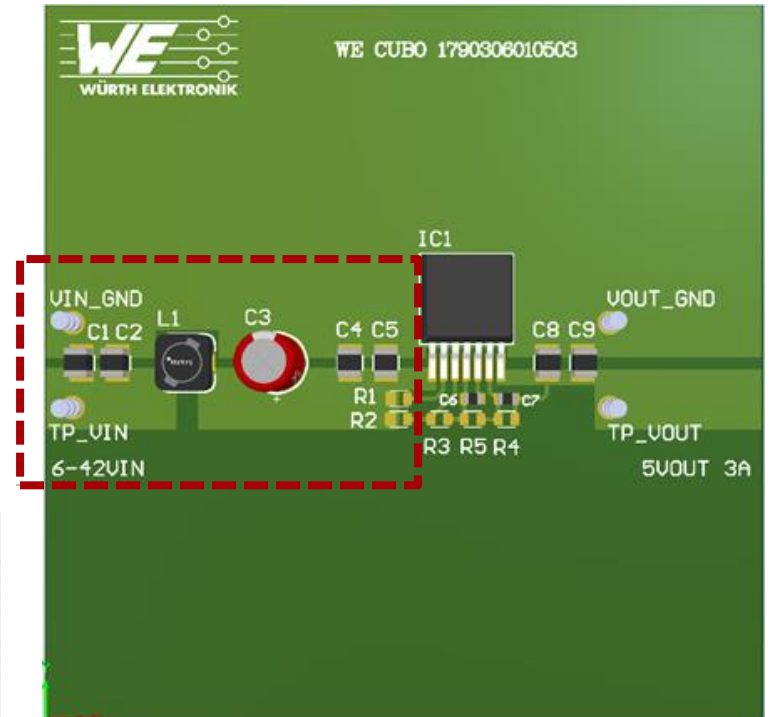
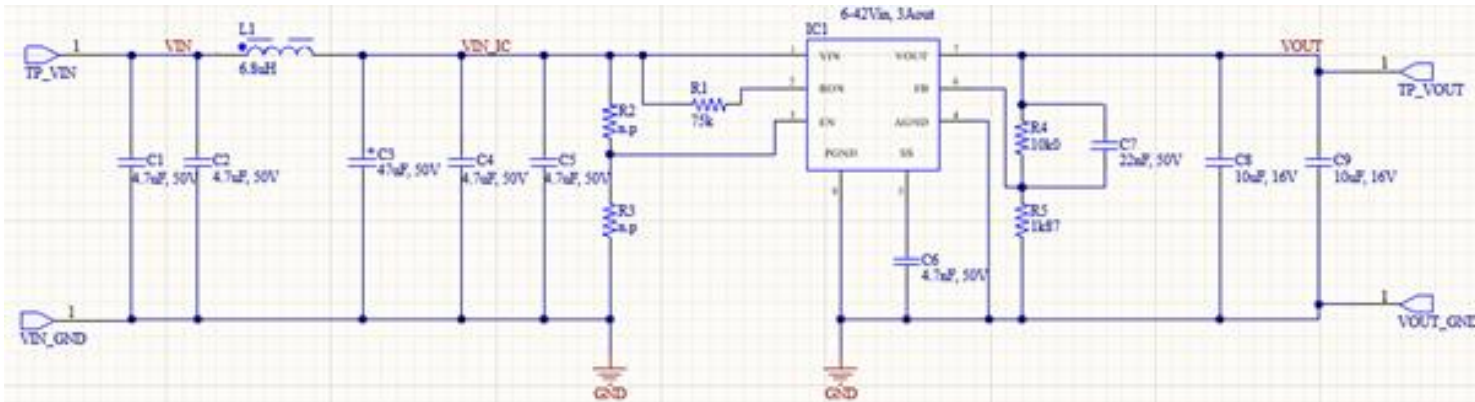

INTRODUCTION TO EMC

EMC Pre-compliance measurements

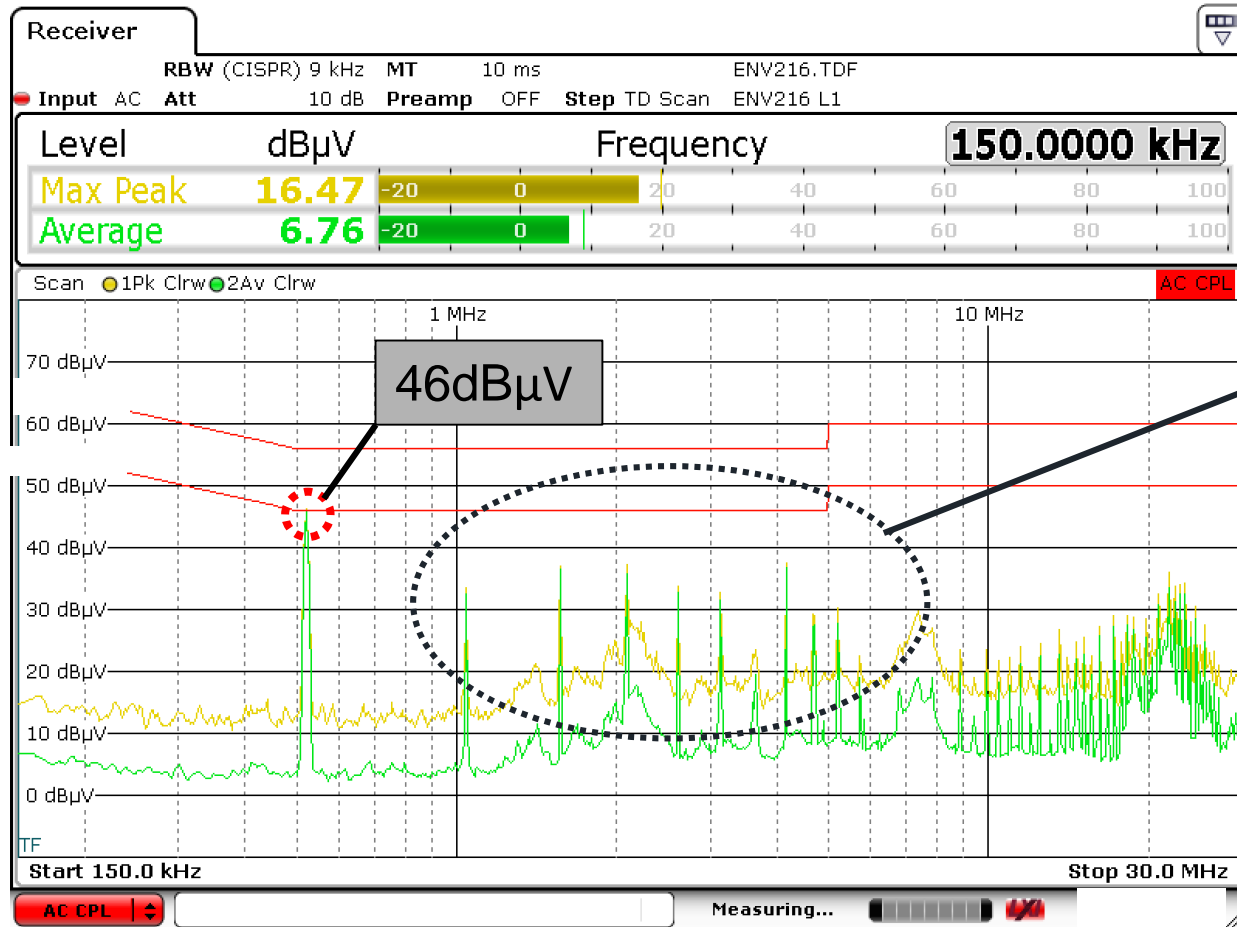

All peaks above 30 dBµV

MagI³C power module
 WE PN: 171032401
 $V_{IN} = 24\text{ V}$
 $V_{OUT} = 12\text{ V}$
 $I_{OUT} = 3\text{ A}$
 $f_{sw} = 500\text{ kHz}$

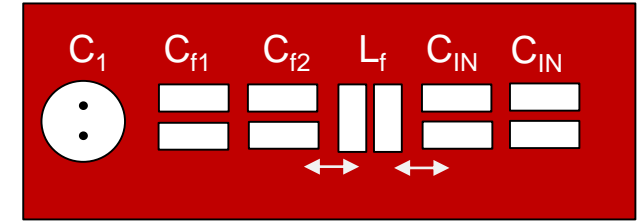

C_{IN} : 2 x 4.7 µF Ceramic near to L_f
 C_f : 2 x 4.7 µF Ceramic near to L_f
 L_f : 6.8 µH unshielded

INTRODUCTION TO EMC

EMC Pre-compliance measurements

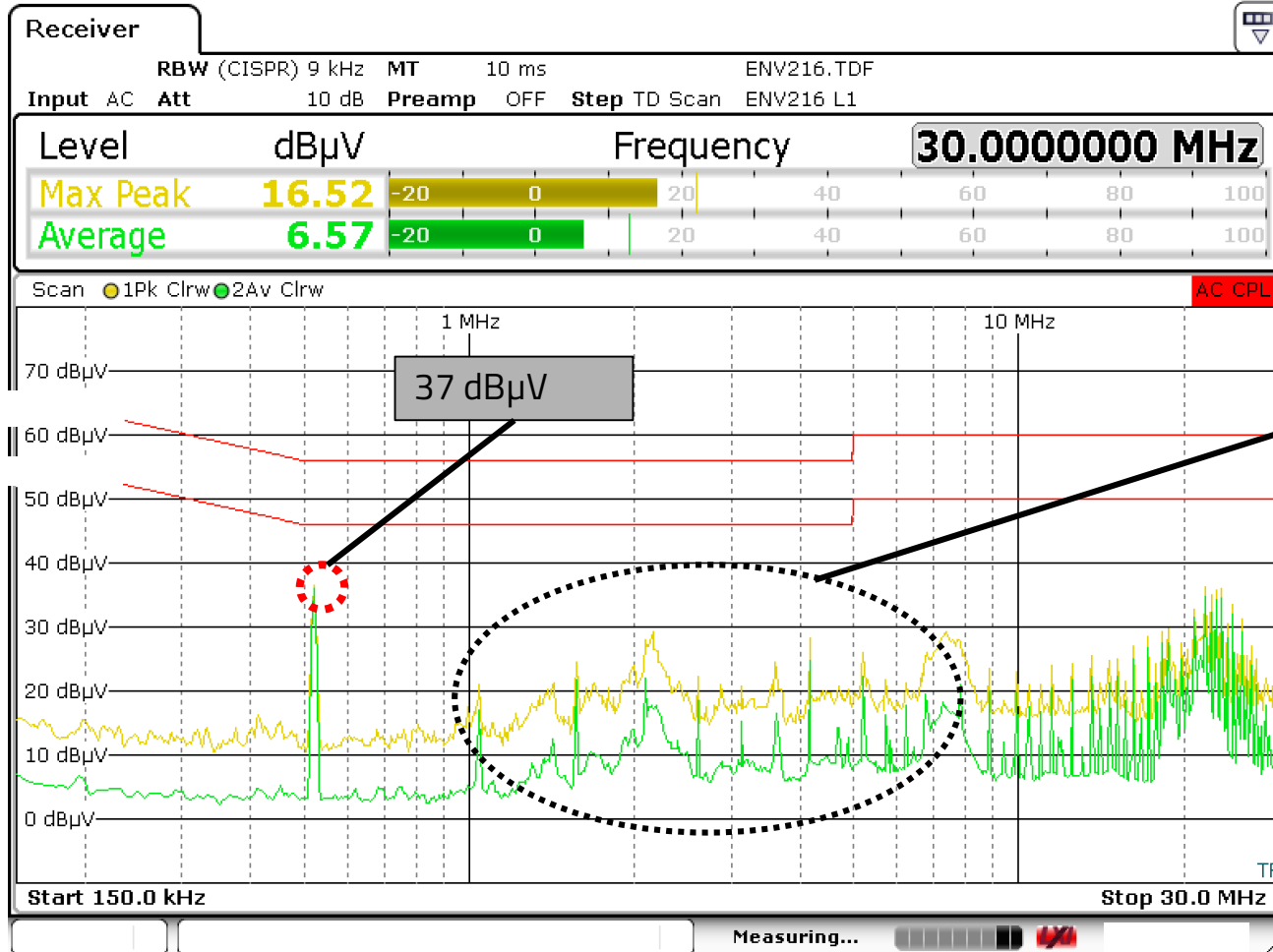

Mag³C power module
WE PN: 171032401
 $V_{IN} = 24\text{ V}$
 $V_{OUT} = 12\text{ V}$
 $I_{OUT} = 3\text{ A}$
 $F_{sw} = 500\text{ kHz}$

All peaks below 30 dB μ V

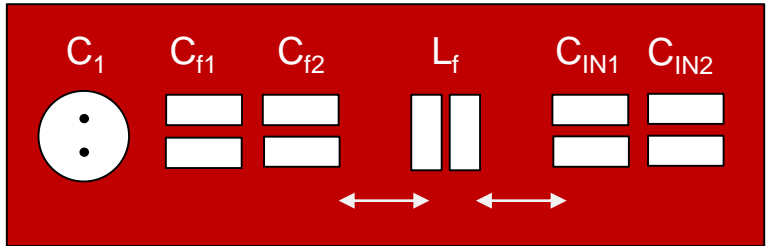

C_{IN} : 2 x 4.7 μ F Ceramic away from L_f
 C_f : 2 x 4.7 μ F Ceramic away from L_f
 L_f : 6.8 μ H unshielded

INTRODUCTION TO EMC

EMC Pre-compliance measurements

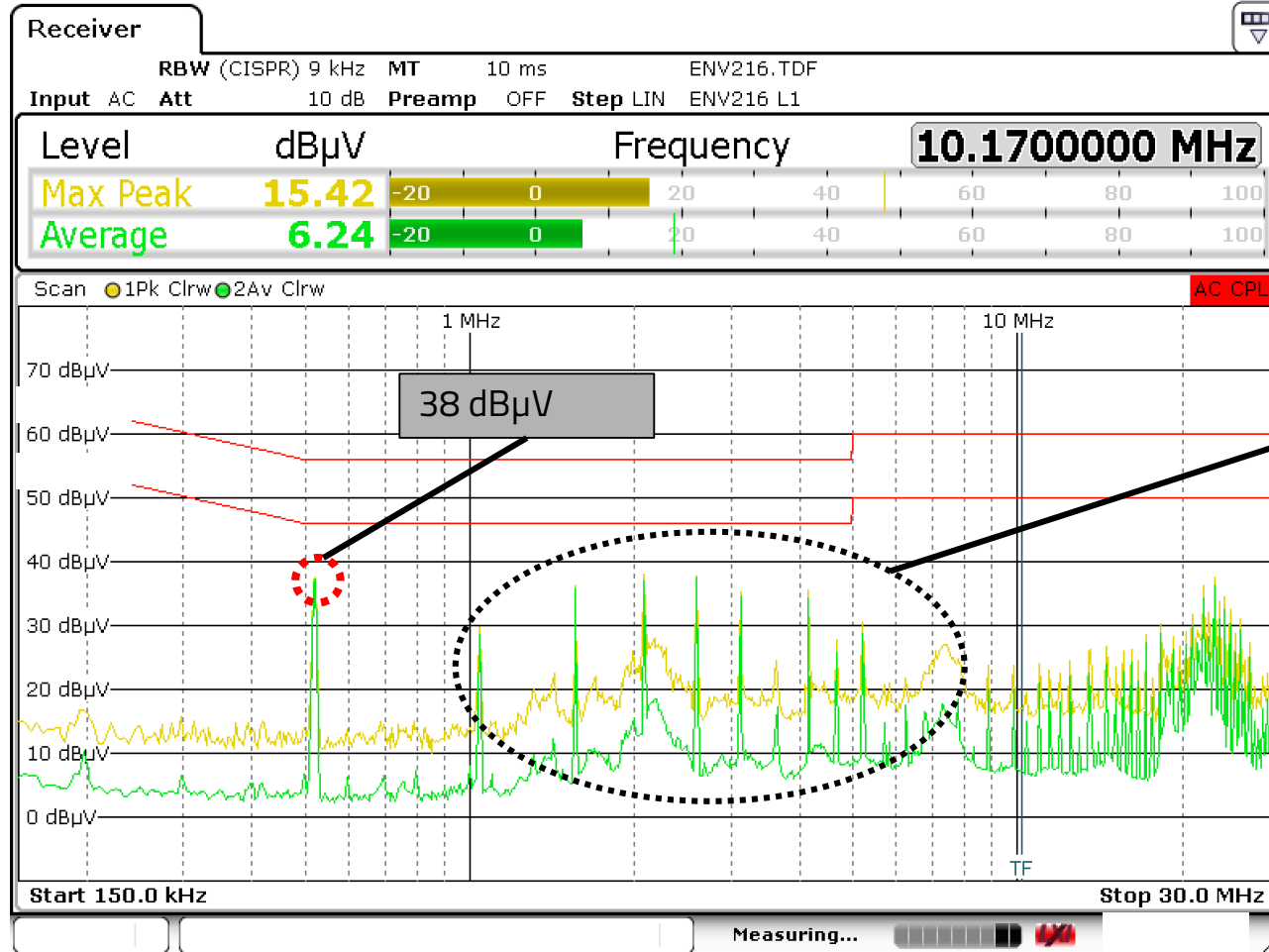

MagI³C power module
 WE PN: 171032401
 $V_{IN} = 24\text{ V}$
 $V_{OUT} = 12\text{ V}$
 $I_{OUT} = 3\text{ A}$
 $F_{sw} = 500\text{ kHz}$

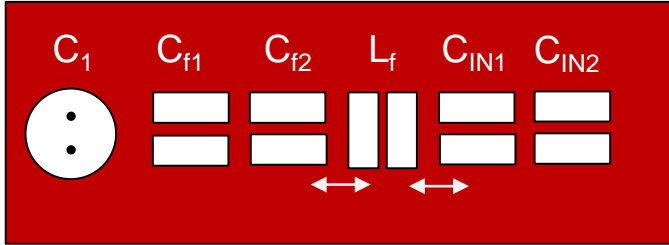

C_{IN}: 2 x 4.7 μF Ceramic near to L_f
 C_f: 2 x 4.7 μF Ceramic near to L_f
 L_f: 6.8 μH shielded

INTRODUCTION TO EMC

EMC Pre-compliance measurements

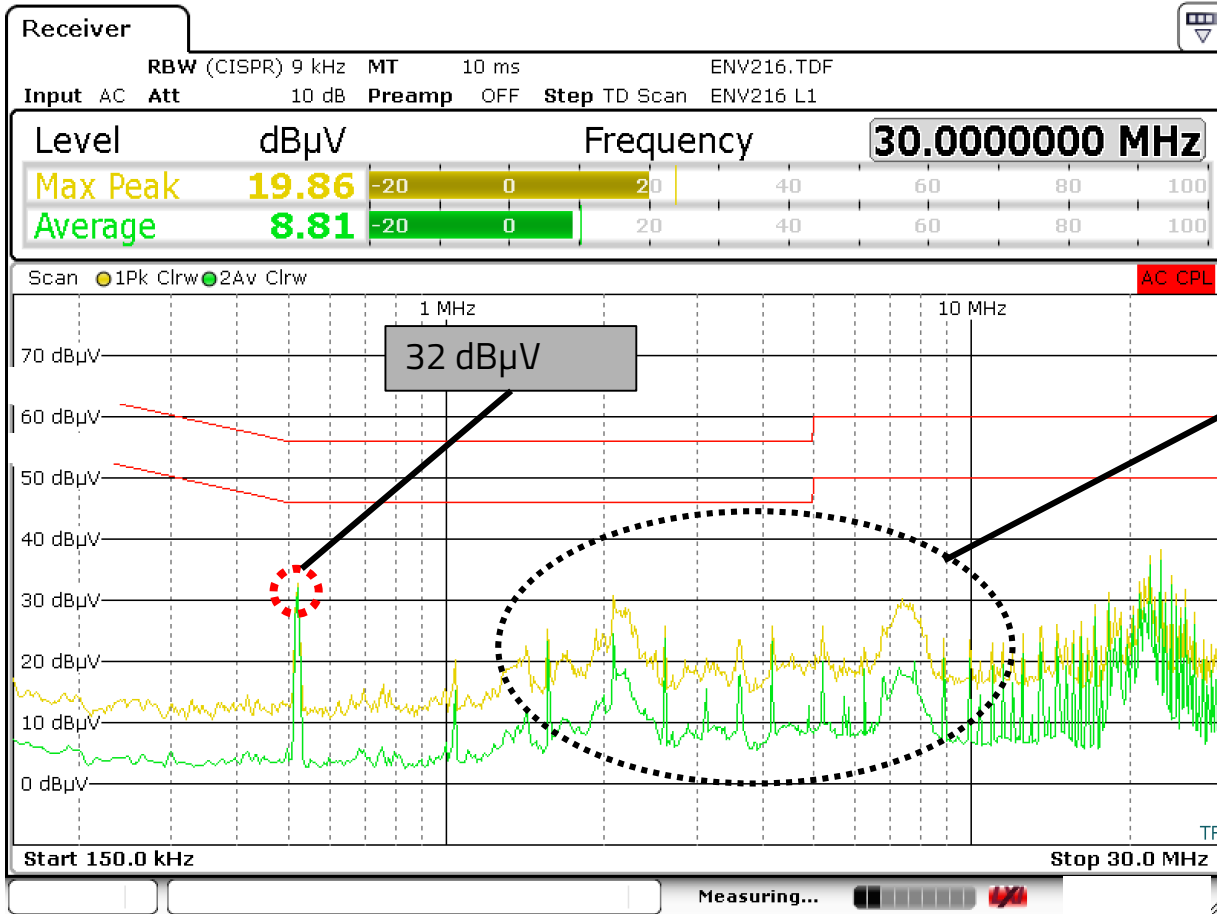

All peaks below 30 dBµV

MagI³C power module
WE PN: 171032401
V_{IN} = 24 V
V_{OUT} = 12 V
I_{OUT} = 3 A
F_{sw} = 500 kHz

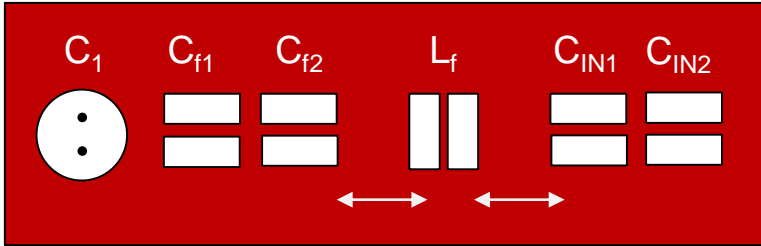

C_{IN}: 2 x 4.7 µF Ceramic **away** from L_f
C_f: 2 x 4.7 µF Ceramic **away** from L_f
L_f: 6.8 µH **shielded**

INTRODUCTION TO EMC

Placement of input filter components; possible options

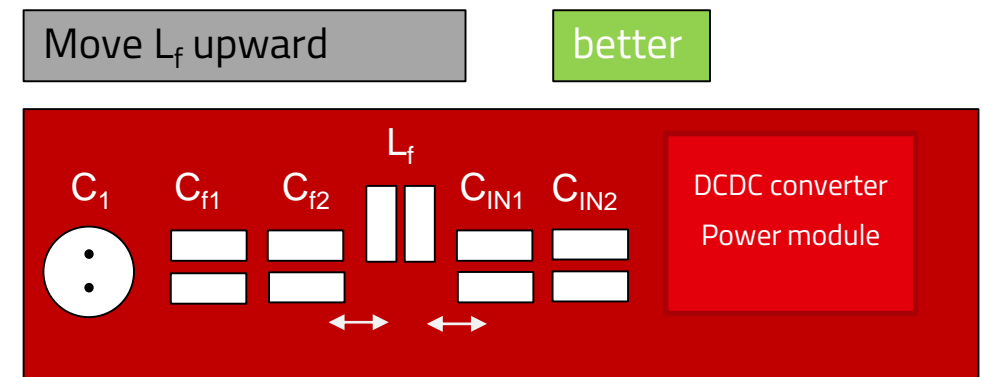
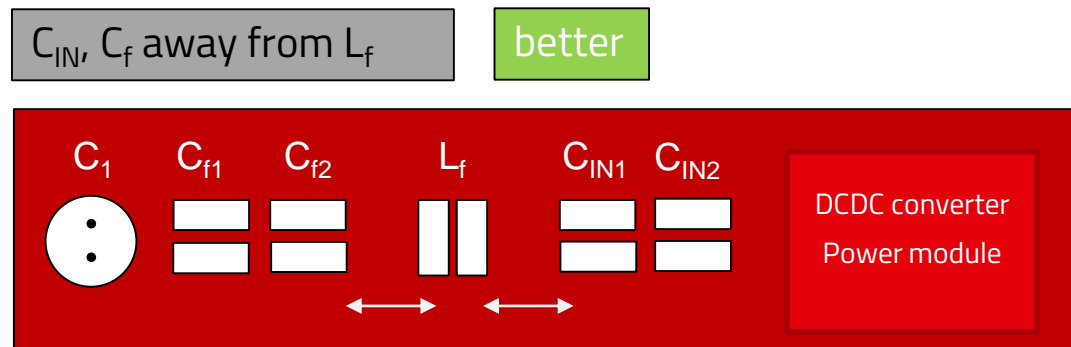
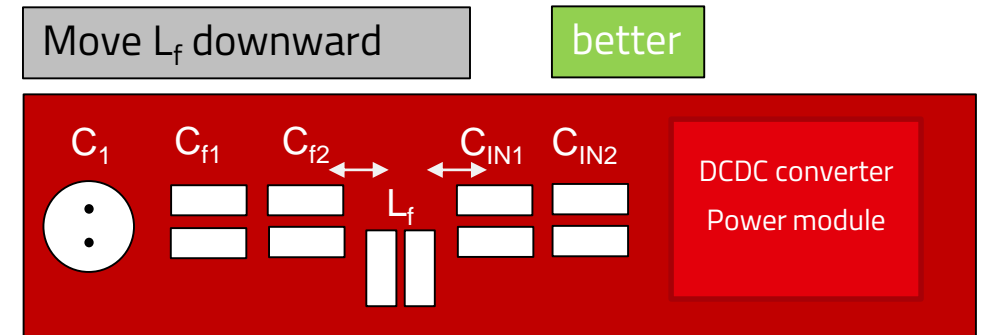
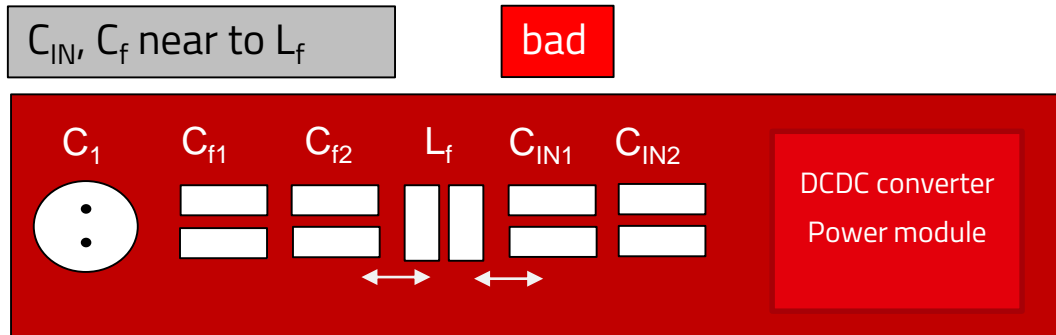

WÜRTH ELEKTRONIK EMC LAB SERVICE

Shielded room

Conducted Emission:

- 9kHz – 30MHz

Conducted Immunity:

- 150kHz – 250MHz

EFT/Burst

- IEC 61000-4-4; Burst upto 5.5kV

Surge

- IEC 61000-4-5; Suge upto 5kV

ESD

- IEC 61000-4-2 upto 16,5kV



WÜRTH ELEKTRONIK EMC LAB SERVICE

Fully Anechoic room

Fully Anechoic Chamber 3m

Radiated Emission:

- 30MHz – 26GHz

Radiated Immunity:

- 80MHz – 6GHz
- Field strengths upto 20V/m

Email: emc.lab@we-online.de

[we-eisos_broschuere_emv-labor_210x297_de_screen.pdf \(we-online.com\)](#)



Questions

& Answers



We are here for you now!
Ask us directly via our chat or via E-Mail.

digital-we-days@we-online.com
Ahsan.Abbasi@we-online.de