

# ICCS MICRO GATEWAY

Controllers

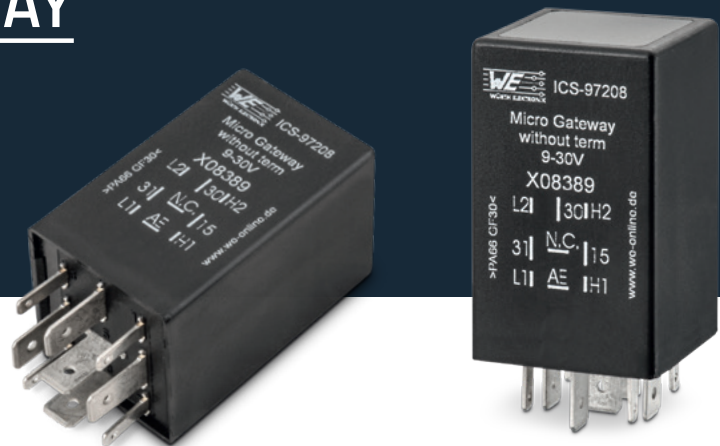

The **ICCS Micro Gateway** facilitates the connection of CAN networks that operate at different bit rates or use different protocols. The compact relay design provides connections for an analogue input, 2 x CAN high-speed, and optionally a LIN bus interface. CAN messages from one network segment can be received, filtered, edited, and transmitted to a connected subnetwork. Implementation and filtering rules allow for protocol adaptation between subnetworks. The optional LIN bus connection facilitates data exchange between LIN and CAN networks.

## Applications

- CAN bridge
- CAN message filtering
- LIN to CAN gateway
- LIN master or slave mode
- Connection of CAN systems with different bus speeds
- Signal manipulation, event triggered suppressing and sending messages
- Connection of LIN sensor to the CAN bus, for example LIN rain, light, or battery sensor

## Technical data

General information	
Connector	9 Pins DIN
Dimensions	30 x 30 x 50 mm
Weight	~30 g
Operating temperature	-40 °C to 85 °C
Storage temperature	-40 °C to 85 °C
EMC	E1
Ingress protection	IP 53
Operating voltage Vsupply	9 to 30 V DC (CAN-CAN) 12 V or 24 V DC (CAN-CAN-LIN)
Pre-fusing	1 A
Current consumption	60 mA
Sleep mode consumption	< 1 mA
Processor type	Freescale HCS12 XEG
Clock frequency	100 MHz
Flash memory	128 kB
RAM	12 kB
EEPROM	1 kB available for graphical programming

CAN bus	
acc. ISO 11898-5	High speed wake on CAN
acc. CAN 2.0B	29 Bits extended address identifier
acc. CAN 2.0A	11 Bits standard address identifier
Baud rate	20 kBit/s to 1000 kBit/s (125 kBit/s default value)

Inputs / outputs overview		
1	Analogue input	0–33.67 V DC 12 Bits
1	Digital input	KL15 activation pin
1	LIN Bus	Optional LIN master

Inputs / outputs details	
<b>Analogue inputs</b>	
Input voltage max	Vsupply
Measuring range	0–33.67 V DC
Resolution	12 Bit
Input resistance	66.68 kΩ
Input frequency	max 50 Hz

LIN bus (optional)	
Pull up to Vsupply	1 kΩ with protection diode
Implementation	acc. LIN 2.1

# ICCS MICRO GATEWAY

## Controllers

### Hardware map

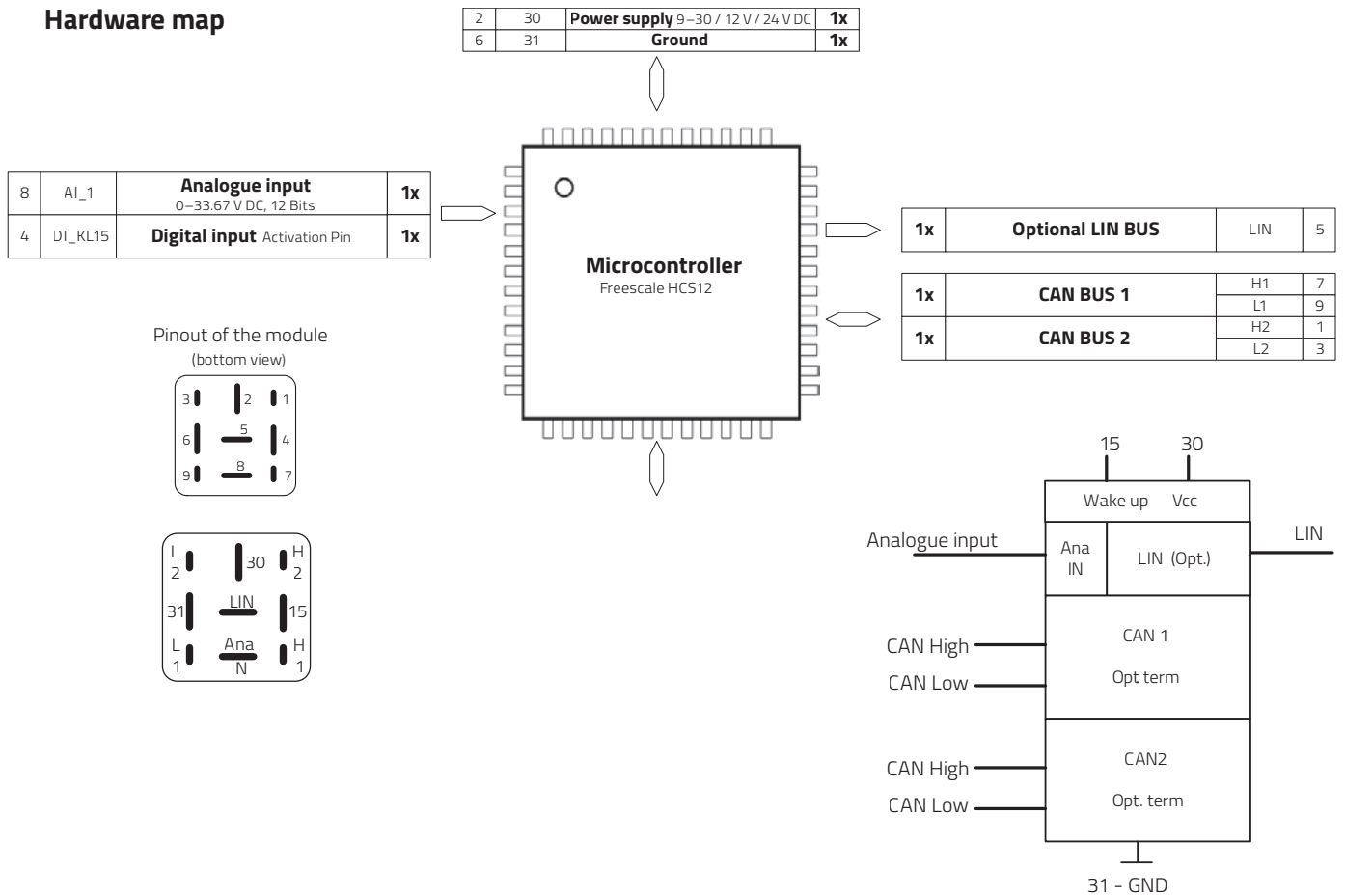

### Pin assignment

ICCS Micro Gateway		
PIN	Description	Function
1	H2	CAN bus 2 High
2	30	Vcc Main Power Supply 9–30 V DC / 12 V / 24 V DC
3	L2	CAN bus 2 low
4	15	KL15 Activation pin
5	LIN (opt.)	Optional LIN bus
6	31	Ground
7	H1	CAN bus 1 high
8	Ana In	Analogue input 0–30 V
9	L1	CAN bus 1 low

### Dimensions



### Order information

Available references	Part number
ICCS Micro Gateway 2 x CAN	ICS-97208
ICCS Micro Gateway 2 x CAN with CAN terminators	ICS-97227
ICCS Micro Gateway 2 x CAN – 1 x LIN master 12 V	ICS-97237
ICCS Micro Gateway 2 x CAN – 1 x LIN master 24 V	ICS-104065

For more information write us an e-mail [ics@we-online.com](mailto:ics@we-online.com), call **+49 7940 9810-0** or visit us at [www.we-online.com/ics](http://www.we-online.com/ics)

**Würth Elektronik ICS GmbH & Co. KG**  
**Intelligent Power & Control Systems**  
 Gewerbepark Waldzimmern · Würthstraße 1  
 74676 Niedernhall · Germany  
 Tel.: +49 7940 9810-0 · Fax +49 7940 9810-1099  
[ics@we-online.com](mailto:ics@we-online.com) · [www.we-online.com/ics](http://www.we-online.com/ics)

This item is a standard product, please consider the relevant datasheet notes. The user is responsible for the product's functionality in its purposed system environment. Technical content may be modified and changed by Würth Elektronik ICS GmbH & Co. KG without any notice.